

Reports of the Research Committee  
of the  
Society of Antiquaries of London

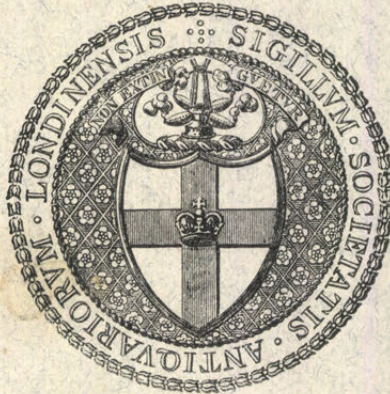
---

No. VI

---

First Report on the  
Excavation of the Roman  
Fort at Richborough, Kent

By J. P. Bushe-Fox, F.S.A.



Oxford

Printed by John Johnson for  
The Society of Antiquaries

Burlington House, London

1926

Price Seven Shillings and Sixpence

# SOCIETY OF ANTIQUARIES

## RESEARCH COMMITTEE

THE EARL OF CRAWFORD AND BALCARRES, K.T., LL.D., F.R.S.,  
*President.*

SIR C. HERCULES READ, LL.D., *Hon. Vice-President.*

SIR ARTHUR J. EVANS, M.A., D.LITT., F.R.S., *Hon. Vice-President.*

REGINALD A. SMITH, B.A., *Vice-President.*

W. MINET, M.A., *Treasurer.*

CHARLES R. PEERS, C.B.E., M.A., *Director.*

RALPH GRIFFIN, *Secretary.*

J. N. BANKES, *Treasurer of the Richborough Excavation Fund.*

HAROLD BRAKSPEAR.

J. P. BUSHE-FOX.

REV. G. H. ENGLEHEART, M.A.

LT.-COL. WILLIAM HAWLEY.

A. G. K. HAYTER, M.A.

W. G. KLEIN.

W. H. KNOWLES.

E. THURLOW LEEDS, M.A.

D. H. MONTGOMERIE.

WILLIAM PAGE.

T. DAVIES PRYCE, M.R.C.S.

MILL STEPHENSON, B.A.

W. M. TAPP, LL.D.

---

H. S. KINGSFORD, M.A., *Assistant-Secretary.*



# CONTENTS

	PAGE
GENERAL SUMMARY . . . . .	I
Historical References . . . . .	4
Summary of Evidence obtained in 1922-3 and from Previous Discoveries . . . . .	5
DESCRIPTION OF THE EXCAVATIONS . . . . .	9
Road Sections . . . . .	25
Other Recent Discoveries . . . . .	29
THE MARBLE CASING . . . . .	35
THE SCULPTURED SLAB . . . . .	37
THE PIG OF LEAD . . . . .	42
SMALL OBJECTS IN METAL, BONE, ETC. . . . .	42
THE POTTERY—	
Decorated Samian . . . . .	49
Potters' Stamps . . . . .	54
Potters' Stamps on Samian . . . . .	55
Stamps on Decorated Samian . . . . .	55
Stamps on Plain Samian . . . . .	60
Stamps on Belgic Ware, Lamp, and Amphorae . . . . .	84
Stamps on Mortaria . . . . .	87
Coarse Pottery . . . . .	88
THE COINS . . . . .	106

## LIST OF ABBREVIATIONS

<i>Antiq. Journ.</i>	<i>The Antiquaries Journal.</i>
<i>Arch.</i>	<i>Archaeologia.</i>
<i>Arch. Ael.</i>	<i>Archaeologia Aeliana.</i>
<i>Arch. Camb.</i>	<i>Archaeologia Cambrensis.</i>
<i>Arch. Cant.</i>	<i>Archaeologia Cantiana.</i>
<i>Bonn. Jahrb.</i>	<i>Bonner Jahrbücher.</i>
<i>C.I.L.</i>	<i>Corpus Inscriptionum Latinarum.</i>
Cohen.	Cohen, <i>Description historique des monnaies frappées sous l'Empire Romain.</i>
<i>Corbridge Report.</i>	Reports on the excavations at Corstopitum published in <i>Archaeologia Aeliana.</i>
Déch.	Déchelette, <i>Les vases céramiques ornés de la Gaule Romaine.</i>
Drag.	Dragendorff, <i>Terra Sigillata</i> , in <i>Bonner Jahrbücher</i> , 96, 99.
Fölzer.	Fölzer, <i>Die Ostgallischen Sigillatamanufakturen.</i>
Grueber.	Grueber, <i>Coins of the Roman Republic.</i>
<i>Haltern.</i>	Loeschke, <i>Haltern.</i>
<i>Hengistbury Head.</i>	Bushe-Fox, <i>Report on Excavations at Hengistbury Head.</i> Reports of the Research Committee of the Society of Antiquaries, III.
<i>Hedd. Mitt.</i>	<i>Heddernheimer Mitteilungen.</i>
<i>Journ. Brit. Arch. Assoc.</i>	<i>Journal of the British Archaeological Association.</i>
<i>J.R.S.</i>	<i>Journal of Roman Studies.</i>
Lud.	Ludowici, <i>Rheinzabern.</i>
M. & S.	} Mattingly & Sydenham, <i>Roman Coins from Augustus to Vitellius.</i>
Mattingly & Sydenham.	
May, <i>Carlisle</i>	} May & Hope, <i>Catalogue of Roman Pottery in the Museum, Tullie House, Carlisle</i> , in <i>Trans. Cumb. &amp; Westm. Ant. &amp; Arch. Soc.</i> , N.S., 17.
May, <i>Tullie Ho. Cat.</i>	
May, <i>Silchester Nass. Ann.</i>	May, <i>The Pottery found at Silchester.</i>
<i>Newstead.</i>	} Curle, <i>A Roman Frontier Post: the Fort at Newstead.</i>
Curle, <i>Newstead.</i>	
Newstead ( <i>Report</i> ).	

## LIST OF ABBREVIATIONS

vii

- O.R.L.* *Der Obergermanisch-Raetische Limes.*
- Oswald & Pryce. Oswald & Pryce, *An Introduction to the Study of Terra Sigillata.*
- Proc. Soc. Ant.* *Proceedings of the Society of Antiquaries.*
- Proc. Soc. Ant. Scot.* *Proceedings of the Society of Antiquaries of Scotland.*
- Rev. Archéol.* *Revue Archéologique.*
- Ristissen-Festschrift.* Knorr, *Ristissen-Festschrift.*
- Sussex Arch. Coll.* *Sussex Archaeological Collections.*
- Swarling Report.* Bushe-Fox, *Report on Excavation of the Late-Celtic Urn-field at Swarling, Kent.* Reports of the Research Committee of the Society of Antiquaries, V.
- Trans. Cumb. & Westm. Ant. & Arch. Soc.* *Transactions of the Cumberland and Westmorland Antiquarian and Archaeological Society.*
- V.C.H.* *Victoria County Histories of England.*
- Walters, *Lamps.* Walters, *Catalogue of Roman Lamps in the British Museum.*
- Walters B.M. Cat. Walters, *Catalogue of Roman Pottery in the British Museum.*
- Wheeler, *Segontium* Wheeler, *Segontium and the Roman Occupation of Wales in Y Cymmrodor*, 33.
- Woolhope Field Club Report.* Jack, *Excavations on the site of the Romano-British town of Magna, Kenchester.* Report of the Research Committee of the Woolhope Club.
- Wroxeter.* Bushe-Fox, *Excavations on the Site of the Roman Town at Wroxeter, Shropshire, 1912, 1913, 1914.* Reports of the Research Committee of the Society of Antiquaries, I, II, and IV.



# *Excavations at Richborough, Kent*

By J. P. BUSHE-FOX, F.S.A.

DURING the summers of 1922 and 1923 excavations within the area of the Roman fort at Richborough were carried on under the auspices of the Research Committee of the Society of Antiquaries. The guardianship of this place is in the hands of His Majesty's Office of Works, and this Department not only gave permission but has also afforded every facility for the undertaking.

The following report deals with the discoveries made during these two seasons, and also with some finds made by the Office of Works while recently uncovering portions of the walls of the fort, the west gateway, etc. The excavation of a site of this description, where small objects are numerous, entails a large amount of work and constant supervision, with which it would have been far beyond my powers to cope without the assistance of several very able helpers; and although it has fallen to my lot to record the results of the excavations, a great part of the material embodied in this report is the result of the labours of others.

Among those who have taken part in the excavations Mr. W. G. Klein, F.S.A., assisted in the supervision each summer. Mr. Thomas May, F.S.A., has also worked on the site during the whole of each season, and has dealt mainly with the pottery, the very careful drawings of the coarse ware in this report having all been made by him. Mr. A. G. K. Hayter, F.S.A., has been responsible for the laborious task of identifying and listing the coins and potters' stamps, the former amounting to 3,133, many being very corroded and difficult to decipher. In addition to these the following spent much time upon the site and gave very valuable assistance in many and various ways: Mr. H. Wilmer, F.S.A., Mr. J. G. N. Clift, Mr. W. P. D. Stebbing, F.S.A., Mr. C. A. R. Radford, Mr. E. Jervoise, Mr. H. D. Colt, Mr. and Mrs. Hodges, and Miss Hobling. The excellent plans have been prepared by the Architectural Staff of H.M. Office of Works.

Richborough has in the past received considerable attention from archaeologists and others, but little scientific or systematic excavation has been undertaken. As might be expected, the great concrete foundation has formed the principal attraction, but in



## 2 REPORTS OF THE SOCIETY OF ANTIQUARIES

spite of the repeated attempts to ascertain its purpose and the many ingenious, if not always probable, theories propounded, it still remains a mystery, which it is hoped the excavations now being undertaken may solve in due course. There is a large amount of literature in connexion with the site, the remains above ground and previous discoveries having been often and fully dealt with; this will be found summarized in the Official Guide to Richborough issued by H.M. Office of Works. It is not intended, therefore, to go over these again here at any length, but as this is the first of what will probably be a series of reports on the complete excavation of the site, a few introductory remarks on its past history, etc., are necessary.

Richborough, the Roman Rutupiae, is situated on an undulating hill about a mile and a half to the north of Sandwich, and is completely surrounded by marsh, a narrow strip of which divides it from the rising ground to the west. It may be assumed with some confidence that the high ground on which Rutupiae stood formed, at any rate at high tide, an island which must in Roman times have been connected with the mainland by a bridge or causeway. This would probably have been placed at the narrowest point, which lies a little to the south of the present road running from Richborough westward. That originally a road ran from the site to Durovernum, the modern Canterbury, is undoubted, but its line cannot now be traced, although the straight stretch of road leading out of Canterbury past St. Martin's Church eastward to within about a mile of Littlebourne is in all probability part of it, and there are also some indications of its existence to the east of Ickham. The Roman road connecting Rutupiae and Portus Dubris (Dover) is still in evidence for the greater part of its length, passing near Whitfield and through Eastry and Woodnesborough. North of the latter place it entirely disappears, and there is nothing to indicate whether it ran direct to a point on the edge of the marsh opposite Richborough or turned slightly north-west, joining the Richborough-Canterbury road just mentioned. It is hardly conceivable that the site was connected by a direct road with its sister fort at Reculver, the Roman Regulbium, which guarded the northern end, as Rutupiae did the southern, of the channel between the Isle of Thanet and the mainland. The estuaries of the Great and Little Stour, then tidal inlets of the sea, would have had to be negotiated, and it is probable that if a journey by road between the two forts were undertaken the route would have been through Fordwich or Canterbury. A simpler and more direct means of communication would have been by boat, by which intercourse must have been maintained with the

Roman settlement at Minster directly north of Rutupiae on the Thanet side of the Wansum.

The geographical position of the site made it eminently suitable as a port for shipping plying between this country and the Continent, and the light-draught ships of the period could either have been drawn up on the shore or have found good and sheltered anchorage to the north or south-west of the island.

That a town of considerable size existed is shown by the numerous relics that have from time to time been found scattered over a wide area. These occur in greatest profusion on the high ground to the east, which would therefore appear to have been the most densely occupied. Little or nothing is as yet known of the plan of the town, but indications that it was laid out in insulae in accordance with the usual Roman practice have been recorded (Roach Smith, *Richborough, etc.*, p. 52). What were believed to have been granaries were discovered near the edge of the cliff (*Arch. Cant.* xviii, 12), and a building was found at the south-east corner of the site (Roach Smith, *Richborough, etc.*, p. 54). An amphitheatre, 200 ft. by 166 ft., situated on the highest part of the island on the southern side, was excavated in 1849 (Roach Smith, *Richborough, etc.*, p. 52), and probably belongs to an early period, as a burial with a coin of Constantine 332-50 A.D. was discovered over the remains of the west entrance, suggesting that the structure had fallen into decay long before that date. The presence of this amphitheatre indicates that there must have been a considerable population on the site. The fort itself stands on the edge of a cliff on the eastern side of the island, and its walls, some 11 ft. thick, which remain to an impressive height, as much as 25 ft. in places, are without doubt one of the finest examples of Roman masonry still existing in this country (pl. 1). It is rectangular in plan, measuring on the outer face of the walls 494 ft. north and south and 550 to 580 ft. east and west, the enclosed area being a little over six acres. The main entrance, flanked by two rectangular turrets, is in the west wall, and there was a small postern gate in the north wall. Circular turrets or bastions 18 ft. in diameter are situated at the angles, while between these and the entrances are others, rectangular in plan, which project from the wall some 10 ft. and are about 20 ft. wide. The exact position or character of the east wall cannot now be determined, as it has been displaced by a landslide, but it was probably of the same plan as the others, with a gateway, rectangular projecting turrets, and circular angle turrets. Situated roughly in the centre of the fort and embedded in the soil to a depth of over 30 ft. is a concrete foundation which,

#### 4 REPORTS OF THE SOCIETY OF ANTIQUARIES

as already stated, has excited much curiosity in the past. At ground-level it measures 146 ft. by 106 ft. 4 in., and superimposed upon it is a cruciform concrete construction (pl. xxxi). Large quantities of broken marble casing, consisting of moulded shells for columns and pilasters, cornice mouldings, slabs for wall facings, steps and pavements, have been met with in its vicinity, as well as several fragments of colossal bronze statues, some gilded, and there can be little doubt that originally these formed part of some monumental structure that stood on this huge foundation, which must therefore have been of an unusually ornate character for Roman work in this country.

#### HISTORICAL REFERENCES

The Rutupine shore is mentioned by Lucan (*Pharsal.* vi, l. 67) who died in 65 A.D. and by Juvenal (*Sat.* iv, l. 141) who, writing in the first quarter of the second century A.D., refers to the oysters from that locality, showing that already at that early date the Kentish coast had become notorious for producing this favoured dish of the Romans. In the *Geography* of Ptolemy, c. 120-50 A.D. (ii, 3, 12), Rutupiae is given as one of the towns of the Cantii, a tribe who inhabited a district roughly corresponding to Kent, but whose territory also extended north of the Thames, as the same writer includes London within their area. In the Antonine Itinerary, presumed to have been compiled in the late second or the first half of the third century A.D., it is styled a port or haven. According to Ammianus Marcellinus, c. 370 A.D. (Lib. xx, 1, 3), the general Lupicinus, in the reign of the emperor Julian, embarked with a fleet from Boulogne on an expedition against the Picts and Scots and landed at Rutupiae in 360 A.D. The same writer (Lib. xxviii, 8, 6) also describes it as a safe and quiet station, when recording the fact that the general Theodosius, father of the emperor of that name, disembarked there upon entering this country in 368 A.D. to carry on a campaign against the raiding Saxons and Franks and the turbulent tribes in the north.

The *Notitia Dignitatum*, a document setting out the distribution of the troops over the Empire, the British portion of which is believed to depict the organization of the late fourth century, gives Rutupiae as one of the series of forts which were under the command of the Count of the Saxon Shore, extending along the coast from Brancaster in Norfolk to possibly as far as Porchester near Portsmouth. It also states that the Second Legion was quartered there.

The poet Ausonius (*Clarae Urbes, Aquileia*) gives Magnus Maximus, who was proclaimed Emperor in Britain in 383 A. D., the title of the Rutupine Robber or Brigand, but how he came to merit this is not narrated. The epithet, however, may have no special significance, being a natural enough word for a supporter of the opposite side to use when writing of a man who tried to set himself up as Emperor by armed force. The same writer refers on two other occasions to the Rutupine territory, viz. when mentioning that his uncle Contemtus was buried in the Rutupine soil (*Parentalia*, vii, 2), and in speaking of Flavius Sanctus, under whose rule he says the Rutupine land rejoiced (*ibid.* xviii, 8). It is possible that in all three instances Ausonius may have used the adjective *Rutupinus* for metrical reasons, as a general term for southern Britain.

Rutupis is the form used in the *Tabula Peutingeriana* to which unfortunately no date can be assigned, as it appears to have been compiled from various sources and may be as late as the fifth or sixth century. That only three of the Saxon Shore forts are given, and appear in what is presumably the locative case as Rutupis, Dubris and Lemanis, may be explained by the fact that these places are at the ends of routes such as those in the Antonine and other Itineraries from one of which the names on the map may have been copied.

In Bede, *c.* 680 A. D. (*Hist. Eccl.* i. 1), is the following remark: 'It (Britain) has to the south Gallia Belgica, the nearest shore to which for those who cross is entered by the city which is called Rutubi Portus now corruptly called Reptaceaster by the people of the Angles.' This is evidently copied, like much of Bede's history, from Orosius, *c.* 417 A. D. (*Hist. contra pag.* i. 2. 16).

#### SUMMARY OF THE EVIDENCE OBTAINED FROM THE EXCAVATIONS OF 1922 AND 1923 AND FROM PREVIOUS DISCOVERIES ON THE SITE, ETC.

During the two seasons of 1922 and 1923 only a small portion of the interior of the fort was examined, and it is dangerous, therefore, to draw any definite conclusions at this early stage, but it will be as well to give a short summary of the general impressions obtained concerning the history of the site, although these may in all probability have to be modified or altered by future discoveries.

It is abundantly clear that although Rutupiae was undoubtedly one of the main ports of Britain during the whole of the Roman occupation there were, at any rate as far as the portion of the site

## 6 REPORTS OF THE SOCIETY OF ANTIQUARIES

under review is concerned, two very distinct phases in its history, viz. one when it was simply a town in connexion with the port, and the other when it became the principal fort of the Saxon Shore series. To these we may have to add an early military period, as the evidence obtained from the coins and pottery points very conclusively to an occupation in or immediately after the reign of the emperor Claudius, and that a defensive work should have been thrown up here in the first instance is highly probable. From the fact that several post-holes and burnt layers containing much charcoal were found at low levels it would appear that the earliest buildings were of wood or half-timber construction, as is often the case on Roman sites. That there was also a masonry structure in the first century was shown by the presence of the fragmentary low-level walls on the east side of, and returning under, the foundations of the main building on site 1, but whether these belonged to the middle or end of the century could not be determined.

The portion of the site excavated was heavily occupied towards the close of the first century and in the early years of the second as is indicated by the large amount of pottery of that period that has been recovered. What exactly was the nature of the buildings is not easy to determine, but as there were no signs of masonry structures other than the low-level walls mentioned above, it must be assumed that they were mostly of wood or half-timber. Much working in metal appears to have been carried on at this time; the whole of well 2 was filled with iron slag, copper slag was plentiful, and the remains of several furnaces and portions of small crucibles were met with.

Evidence is accumulating that the great concrete foundation and the building which it carried must be placed early in the history of the site, as fragments of the marble casing, many of them evidently masons' chippings, occurred in deposits that cannot be far removed from 100 A.D. It may not be out of place here to draw attention to the fact that this structure included not only an elaborate architectural composition, but also probably decorative statuary in bronze on a colossal scale. It is tempting therefore to see in the evidence of metal-working on an immediately adjoining site the workshops of the artists and builders employed upon it, as lead and iron would be required for the architectural part of the work and bronze for the statuary and ornaments. The closely dated pig of lead of the emperor Nerva, 96-8 A.D., gives an additional clue to the date of this undertaking, pointing as it does to a period remarkable for Imperial building throughout the Empire.

The date of the erection of the main building on site I may be roughly placed about the middle of the second century, its foundations being laid in the mixed soil formed by the previous occupations, and in some instances even passing over burnt layers and the mouths of filled-in wells.

It can be reasonably assumed that for some two hundred years—that is, from the second half of the first century until the second half of the third—a town existed on the site which served the purpose of an adjunct to the port through which much of the trade between this country and the Continent must have passed. As already stated, the area excavated was heavily occupied towards the close of the first century and in the early years of the second, but finds were not nearly so numerous from then onwards up to the second half of the third century. This fact may possibly be accounted for by the change from an intensive occupation by artisans employed on the construction of the marble-cased structure, to a purely domestic one when the main building on site I was built.

A considerable occupation of the site during the latter part of the third century may be deduced from the large number of coins of that period found. That there should be as many as sixty-one of Carausius, the admiral of the emperor Maximian, who, with the aid of his fleet and the legionaries in this country, set himself up as emperor in Britain in 287 A.D., suggests that the harbour of Rutupiae may have been used as his naval base, as it may also have been by his successor, Allectus, 293–6 A.D.

Indications have been met with that trouble of some description overtook the town towards the close of the third century. The coins of this period often appear to have been subjected to burning, and the upper part of the large pit, no. 7, the filling of which can be dated with some accuracy between the years 285 and 305 A.D., contained building rubbish, large blocks of dressed stone, and two human skulls, strongly suggesting the clearing-up of the site after a disaster.

Two of the stones in this pit were of very large proportions and probably formed part of the structure on the great concrete foundation. A portion of a colossal bronze statue, which may well have adorned this building, was also found in this pit as well as fragments of the marble casing, and it is evident that the structure was in ruins before the pit was filled in.

Another small piece of evidence for a catastrophe at this period was afforded by a burnt layer near the turret on the south wall, which contained five coins of the period 260–96 A.D., but

## 8 REPORTS OF THE SOCIETY OF ANTIQUARIES

whether this burnt layer was deposited before the building of the turret or after it could not be determined.

That the second-century building on site 1 had ceased to exist some time before the middle of the fourth century is certain, as the rubbish pit no. 1 dug through the line of one of its walls contained eight coins ranging from 260 to 350 A. D.

The date of the building of the fort cannot as yet be definitely fixed, but it probably belonged to the latter part of the third century or to the beginning of the fourth. From the evidence available it does not seem unreasonable to assume that, the town having been overwhelmed in some Saxon raid, the buildings on this part of the site were levelled so that the fort might be erected as a precaution against other similar regrettable occurrences.

No buildings that can with certainty be assigned to the fort-period have yet been met with. Patches of cobble pavement, the remains of hearths, a tank formed of fragments of the marble casing, much burnt clay, etc., have been encountered at high levels, and it may be found that there were no considerable structures of that period, the majority of the buildings having been of wood or wattle and daub.

That the site was of importance in the second half of the fourth century is illustrated by the fact that it was used by two generals as the port of disembarkation in 360 and 368 A. D. (p. 4). The *Notitia*, presumably compiled about the end of the fourth century, states that the second legion was quartered here, and the very large number of coins of that period is emphatic evidence that it was then a centre of great activity. The second legion came to Britain in the early years of the Roman occupation, and is known to have been previously stationed at Caerleon in South Wales, but there is no evidence when it moved to Rutupiae, or if the whole legion was quartered there—legions being occasionally broken up into detachments, each retaining the legionary title. The fact however that it garrisoned Rutupiae in the late fourth century indicates clearly that this part of the country was then a danger zone, the fort being probably the principal station of the Saxon Shore series as well as the chief naval base of the province.

It is known that there was a continual withdrawal of troops from this country by various emperors in the later part of the fourth century and the early years of the fifth to assist them in their wars on the Continent. Few, if any, of these could ever have returned, and the depleted garrison must have been hard pressed to put up a successful defence against the Saxons, Franks, Picts, and Scots who were raiding Britain on all sides. At the very end of the fourth century the general Stilicho accomplished

much towards making the country secure, but eventually he was forced to withdraw a whole legion to assist in the defence of Italy against the Visigoths. In 406 A. D. the barbarian invasion of Gaul separated Britain from the rest of the Roman Empire, and the remaining troops in this country set up emperors of their own. The first two were murdered soon after being elected, and the third, a Briton named Constantine, proceeded to the Continent with a large force, where he was defeated.

The Roman Empire, shaken to the core, could give no assistance to the sorely pressed Britons, and in 410 A. D. the emperor Honorius sent word that they must defend themselves. For how long they succeeded in doing this, or whether eventually help was sent them, is not known, the history of these islands in the fifth century being shrouded in mist.

What part Rutupiae may have played during the closing years of the Roman occupation cannot yet be decided, but it seems natural to suppose that many of the troops left the country from this port and that it would have been one of the last places evacuated by them. The latest copper coins found on the site, with two possible exceptions (p. 111), can all have been issued before the death of Theodosius I in 395 A. D., but this in itself does not definitely indicate that it had then lost its importance, as little copper coinage was issued from the western mints after that date, and it is therefore possible that a large number of late fourth-century coins continued in circulation well into the following century. There are also two later silver coins, one of Honorius, 398 A. D., and another of Constantine III, 407-11 A. D. It should be noted, however, that although the geographical position of the site, when considered in conjunction with the historical evidence, justifies the assumption that the Romans occupied Rutupiae in force during the early years of the fifth century, this is not at present borne out by direct archaeological evidence.

## DESCRIPTION OF THE EXCAVATIONS

The excavations of 1923 were a direct continuation of the work done in 1922, being undertaken on the same portion of the site, and the results of these years are combined in this report.

There was no reason for starting the excavations at any precise spot, as none of the forts of the Saxon Shore has ever been thoroughly examined, and there is consequently no evidence available of the lay-out within the area of their walls. Fortunately, however, in the dry summer of 1921 it was possible to trace a series of brown lines in the grass, apparently indicating the



presence of walls near the surface of the soil, the grass above them having changed colour owing to lack of moisture. The area where these were most pronounced was a short distance to the north-west of the large concrete foundation, and as it was considered advisable to start the first year's operations at a point where buildings were likely to be met with, work was begun upon this portion of the site. It was soon evident that the discoloured grass had not been misleading, as walls were discovered the first day at little more than a foot beneath the present surface. These walls eventually proved to be the foundations of the main building on site 1 (pl. xxxi), which fronted on to the north side of a road running from the centre of the western edge of the concrete platform to the gateway in the west wall of the fort. Over the whole area, beneath what must have been the floor-level of this building, were some 4-6 ft. of mixed soil containing much evidence of earlier occupation, and the fragmentary remains of one masonry structure passed actually under the foundations of the eastern wall of the main building.

Just before the excavations were closed down in 1923, a ditch was discovered, running roughly north and south through the western part of the area examined, as shown on pl. xxxii. At a period not yet determined this ditch had been filled in with clay, the undoubted purpose being to prevent as far as possible any subsidence, which would have taken place had it simply been levelled up with mixed soil. This clay filling was responsible for its discovery, as owing to clay being foreign to the ordinary soil on the site, cuts were made through it in order to discover its purpose. Time did not permit of a thorough exploration of this ditch, but enough was done to establish the fact that it ran in a straight line from a point near the north edge of the east-and-west road to the north of room 7, where it began to curve gradually towards the east (pl. xxxii). In plate v, fig. 2 the ranging pole is standing in the bottom of the ditch.

A cut was made across it at right angles at the point indicated on pl. xxxii, and the section (pl. xxxiii) was obtained showing that it had been dug some 4 ft. 6 in. into the natural sand and was between 13 and 14 ft. in width. The lower part was V-shaped, and on the eastern side about 18 in. above the bottom was a ridge or offset slightly concave in section and roughly a foot wide. This section is very similar to that of the early camp at Hofheim, 40-51 A. D. (*Hofheim*, pl. iv, 6 and 10), and that the Richborough ditch may also be part of the defences of a camp is probable, but can only be ascertained for certain by future excava-

tion.<sup>1</sup> Farther to the north, where it was turning eastward, the bottom was flat about 1 ft. in width, and plate v, fig. 1 shows the trench cut in order to trace its course at this point, the light portion at the bottom being the natural sand forming the sides and bottom of the ditch. The filling had obviously been disturbed in more than one place, and it was therefore unsafe to form any conclusions as to its date from the few pieces of pottery recovered, several of which were, however, of the second century or later. A coin of Claudius I, 41 A. D., was found lying on the natural sand at the bottom where the ditch turned eastwards.

Pit 14 (p. 20), situated to the west of this ditch, contained the earliest group of pottery found on the site, all the Samian and several of the potters' stamps being of the same type and date as those found in the early camp at Hofheim, 40-51 A. D., while some of the coarse ware examples were of such typical Late Celtic character that, had they been found unassociated with the Samian, they would almost certainly have been assigned to a date prior to the Claudian invasion of this country. The finds from this pit indicate that the site was occupied within about ten years of the Claudian invasion in 43 A. D., and further evidence of this is afforded by such fragments of decorated Samian as pl. xvii, no. 3, pl. xviii, no. 4, a fair number of plain vessels of types similar to those from the early camp at Hofheim (40-51 A. D.), the stamps of several Claudian potters and sixteen coins of the Empire including thirteen of Claudius issued before his death. There were also six Republican coins which, however, might have been brought to the site at a later date as they remained for a long time in circulation. Many fragments of coarse ware vessels that might well have been in use in the middle of the first century were also found, but very close dating of these is not possible.

There were no actual structures that could be assigned to the earliest period, the evidence of their existence being practically confined to postholes (marked P. H. on pl. xxxii) and burnt layers, etc., which would appear to indicate that the first buildings were of wood. One of these burnt layers, under room 5 and resting on the natural sand, contained fragments of pottery that might well be before 50 A. D. Pit 14, as already stated, was filled with rubbish of this period. Pit 2, although probably filled about the end of the first century, appears to have been open in the early period, as near the bottom a coin of Claudius and a stamp of the potter Licinus (P. no. 36 (A)) were discovered. Pit 13 may also have been open in the time of Claudius,

<sup>1</sup> For other examples of ditches with somewhat similar section see *O. R. L.* xxxiii, *Stockstadt*, pl. 111, 3, and *Arch. Camb.*, ser. 6, vol. xiv, p. 7.

as a coin of that emperor was found at the bottom. It also appears probable that well 1, situated partly under the dividing wall between rooms 5 and 7, was open at this period, as the glass cup, pl. XIX, no. 7, similar to an example found in the first period at Hofheim, 40-51 A. D., was lying near the bottom, and the coarse pottery in association with it had early characteristics. A coin of Claudius was found on the earliest road surface in section 5, pl. xxxiv. A curious find that must be very early in date, in fact probably before any buildings existed on this part of the site, was a cremated burial, which was situated under the centre of courtyard 6 of the later building, and had been deposited in a roughly circular hole in the natural sand, measuring about 14 in. in diameter and 6 in. deep. Nothing was found with it.

The earliest masonry structure met with was the wall running practically parallel to the east side of the main building on site 1, returning at its northern end under room 3 and at its southern in front of courtyard 6 (pls. III and xxxi). Both of these return walls had broken ends, and it was found impossible to trace any more of this building. The walls were composed of waterworn cobbles set in light-coloured mortar, the foundation being of cobbles set in clay (pl. xxxiv, section 5). It stood on an average three courses high, 1 ft. 10 in. to 2 ft. wide, and must have been destroyed to its present height before the later building was erected. From near its north-east angle there extended for a short distance a rough chalk foundation. It is possible that the purpose of this building may be explained when the lay-out of the whole site is revealed by future excavation, but little more can be said now than that it appears to have been constructed in the first century A. D., the majority of the finds at its level being of that date.

Our knowledge of the site as a whole is so meagre at present that it is very difficult to formulate any theories from the small area excavated; it is quite evident, however, that there was an intensive occupation in the late first century A. D. and in the early second, as nearly the whole of the mixed soil under what must have been about the floor-level of the main building on site 1 contained débris of that period. In spite of every effort being made, such as taking off the soil in shallow layers, following the slight remains of mortar floors, the patches of burnt matter and layers of rubbish and clean sand which occurred indiscriminately at all levels, practically nothing could be obtained that was sufficiently definite to plan, and it would almost seem as if this area had been occupied at that period by what could only have amounted to a series of shanties of a temporary character. Well 2 with the remains of

a furnace to the north-west was discovered under 6 of the later building. This furnace (pl. II, fig. 2) was composed of broken tiles set in clay, and measured internally 1 ft. 4 in. to 1 ft. 6 in. wide, 9 in. deep, and 6 ft. long. The interior face of the walls and the floor were of clay which showed signs of having been subjected to great heat. The floor itself was 5 in. thick and sloped up gradually from the mouth of the furnace, being covered with a thick layer of burnt matter mostly composed of wood ash. There was nothing to show the original height of the walls, whether the furnace had been domed over, or for what purpose it had been used. Farther to the south were the remains of a large urn and an amphora in an upright position, their bases firmly embedded in the natural soil; they had probably been used as storage jars inside a hut. Two patches of very thin mortar flooring at about one foot above the natural soil level were found as indicated on pl. xxxii. The most westerly of these was covered with a burnt layer containing wood ash, and it is probable that a wooden building had been destroyed by fire at this point. Heavily burnt layers were also met with at a low level under the corridor and rooms 1, 4, and 5. In some instances they ran under the foundations of the later building, but as a rule they had been cut through when these were constructed. These low-level burnt layers, which varied from less than an inch to upwards of 6 in. thick, were generally only a few inches above the natural soil level, and contained many oyster shells, a few pieces of painted wall plaster, fragments of pottery, etc., the latter mostly belonging to the second half of the first century A. D.

That the people who occupied this part of the site in the late first and early second centuries had been extensively employed in metal working was evident. Well 2, with the exception of a few scraps of pottery apparently of first-century date, a broken pioneer's axe of iron, and two beads, was entirely filled with iron slag, fragments of the clay wall of a furnace being still attached to some of the pieces. Many lumps of copper slag were also found, as well as bronze runnings and pieces of small crucibles, while here and there were layers of sand containing numerous small particles or drops of copper, while a carefully folded strip of silver also came from this part of the site. The unfinished brooch (pl. XII, no. 5) from pit 2 cannot be far removed in date from 100 A. D. When we add to this the fact that the partly used pig of lead (pl. XI), inscribed with the name of the emperor Nerva, was found in the soil about 1 ft. 6 in. under what must have been the floor-level of room 4 of the later house, it will be seen that there was

evidence for working in iron, lead, copper, and silver at this period.<sup>1</sup>

The oven situated under the dividing wall between rooms 2 B and 3 was of a type not uncommon on Roman sites, and may well have been used for baking bread. It had been formed by digging a pit, of which one face was left vertical and the other cut into a rough flight of steps. The top part of the vertical face was then removed to a depth of 3 ft. 6 in., the oven being formed in the space thus provided by lining it with clay and doming it over with the same material. The dome had in this instance collapsed and was lying on a layer of burnt matter mostly composed of charcoal, which was separated by a layer of clean sand from a similar burnt deposit on the clay floor. The oven, which measured some 3 ft. 6 in. across, was roughly semicircular in shape with a brick-arched opening about a foot high, the floor of the interior gradually sloping upwards from the mouth. Access for stoking was obtained by the steps on the opposite side of the pit, the filling of which contained a late first-century Samian dish, form 35, in four fragments, affording a clue to the period when this oven fell into disuse.

We now come to the main structure on this site (pls. II, fig. 1, and xxxii), which appears to have been a dwelling-house fronting on to the north side of the main east-and-west road, and divided from the large concrete foundation to the east by another road running north and south. The front part of this building consisted of three oblong enclosures, nos. 6, 9, and 10. At the back of these was a series of rooms, access being obtained to nos. 1, 2 A, 2 B, 3, and 4 by a corridor leading from the north end of 6. Nos. 5 and 7 were situated at the back of 9 and probably communicated with it, and also with nos. 4 and 8 respectively. The latter of these may also have been entered from no. 10.

Whether 6, 9, and 10 were open courtyards or large covered rooms cannot now be determined, but two groups of flints, separated by about 8 ft., which may have formed the packing of wooden uprights, were found towards the northern end of the axial line of 6, and it is therefore possible that a central row of posts supporting a roof originally existed.

In accordance with the usual Roman practice the foundations of the walls were composed of cobbles set in clay. These foundations varied from over 2 ft. to less than 1 ft. in depth, and were inaccurately set out for the finished plan of the building, with the result that the walls were seldom placed centrally upon them.

<sup>1</sup> Mr. Garstang during his excavations found an inscribed ingot of silver. *Arch. Cant.* xxiv, p. 271.

A good example of this may be seen towards the southern end of the east wall of the building where the masonry oversails the clay and cobble foundation on the east side by some 10 in. to a foot (pl. xxxiv, section 2). No foundation was provided for the east walls of rooms 2 A and 2 B, but that of the dividing walls between rooms 1 and 4 and 2 B and 3, 10 in. deep and 2 ft. 10 in. broad, was carried under the line of the corridor at a point where no wall existed or could ever have been intended (pl. iv, fig. 1 (A)).

The masonry of the walls was composed of courses of water-worn flints set in mortar, averaging three courses of flint to the foot (pl. 11). The mortar was generally of good quality, containing a large proportion of grit and fair-sized pebbles of a warm brown colour, apparently from the local gravel beds. The west walls of rooms 1 and 4 and all but a few feet at the southern end of the west wall of 6 were built in whitish mortar. The same feature occurred in the remains of the walls of rooms 5, 7, and 8, and it was obvious that sand and pebbles from a different source, possibly the shore of the Wansum, were used when this part of the building was constructed. The south-east angle of 6 and the north-west angle of 1 were built in courses of tiles extending 3 ft. 6 in. to 4 ft. from the angles on either side. The north-east angle of 2 A had entirely disappeared, but it is probable that this was also constructed of tiles which, after the building had fallen into decay, were removed for use in some other structure. This method of building the principal external angles was a sound one, as difficulty would have been experienced in constructing them satisfactorily with the rough flints similar to those used in the walls.

On the outer face of the east wall and bonded into it were the remains of a buttress which projected 1 ft. 6 in. (pl. 111, fig. 1). It was 3 ft. wide and of the same material as the walls of the house, but the top course remaining was a lacing one of tiles. There were also the remains of what may have been another buttress a little farther to the north on the same wall, and a third on the south wall, but there was no indication of either of these having been bonded into the main wall. Their presence suggests that the wall carried up to a considerable height, the purpose of the buttresses being possibly to take the thrust of a roof, thus affording another slight piece of evidence that 6 was covered in and not an open courtyard.

Some of the walls still stood 4 ft. high above the clay and cobble foundations, and although there were slight indications of an offset in one or two places at the level of the top course, no traces of floors were met with in any of the rooms,

nor was there any evidence of doorways ; and what now remains of this house must originally have been below the floor-level. That this was the case is very clearly shown by the fact that the north wall of 6, one of the highest found, ran through at its full height across the south end of the corridor where a doorway must have existed (pl. II, fig. 2 (c)).

In the north-east angle of 6 were the remains of a tank sunk below floor-level (pl. II, fig. 2 (B)). It measured 3 ft. 8 in. by 5 ft. 8 in., two of its sides being formed by the walls of the building while the others were of cement, still retaining the impression of the wooden shuttering on the outer face. The bottom, some 6 in. thick, was of the same material, one side of it resting on the top of the clay and cobble foundations of the east wall of the house, while a chase, which can be seen on pl. II, fig. 2, had been cut in the north wall of 6, so that the west side of the tank could be bonded into it.

The greater part of the western wing of the building had been destroyed, even the clay and cobble foundations having in some instances entirely disappeared (pl. v, fig. 2), and it is therefore curious that so much of the four substantial brick piers at the western side of room 8 should have been left standing (pls. VI, fig. 1, and XXXIII).

These piers stood in pairs at the west ends of the north and south walls of room 8, being separated from each other by a space of a little over 3 ft. The piers to the east were bonded into the walls of the room and measured 3 ft. 1 in. by 2 ft., while those to the west were 3 ft. 3 in. square and had buttresses of flint masonry on their western sides. One of the piers still stood upwards of 5 ft. in height, and it is evident that each pair carried a supporting arch for the north and south walls of room 8, so that a channel or drain might pass beneath. There was no evidence remaining to indicate whether this drain was lined with stone, tiles, or wood, but a trench or channel cut in the natural sand to the depth of about a foot and packed with flints, stones, gravel, etc., was found running between the bases of the piers (pl. XXXIII). This packing may have served as the foundation of a carefully built channel or have simply formed the bottom of the drain itself, which, after leaving the house, became a V-shaped ditch that could be traced in a straight line northwards up to and beyond the main wall of the fort, while southwards it passed through the south wall of room 10, where there were again traces of two piers. Its end was not reached in either direction, but it is evident that we have here the remains of the drainage system of the house, and that room 8 probably served as the latrine. There was no trace of a west wall

to either 8 or 10, and if one existed it must either have been of wood or half timber, of which all sign would now have disappeared. It is possible 10 may have been a stable, in which case the drain running beneath would have served a useful purpose.

Parallel to the south wall of the house and separated from it by about 11 ft. were the remains of a wall composed of flints set in poor quality mortar (pl. III, fig. 2 (c)). It had no clay and cobble foundation but rested on the surface of a pebble path (pl. xxxiv, section 6). There was no sign of a return to this wall, both ends being ragged, and although its purpose is uncertain it may have originally run the whole length of the south side of the house, serving as a sleeper wall for uprights supporting a portico or veranda.

As already stated, this building had been entirely destroyed to below the original floor-level, and therefore good sealed deposits that might have given valuable evidence of the date of its construction were entirely wanting. Well 1, however, situated partly under the dividing wall between rooms 5 and 7, had been filled with rubbish which contained a coin of Domitian and pottery up to the early years of the second century. When the wall over it was constructed the builders evidently knew of the presence of this filled-in well, and in consequence carried their foundations down to a greater depth, placing a number of broken tiles, etc., over the mouth in order to prevent a subsidence of the wall at this point. With and immediately below this layer of tiles was pottery belonging to the first half of the second century. Pit 11, situated very near the west side of the dividing wall between 6 and 9, could hardly have been dug after this wall was built, and as in the case of well 1 its mouth was covered with a considerable deposit of broken tiles and stones. A large amount of pottery of a mixed character came from the filling, but none was apparently earlier than the end of the first or later than the middle of the second century. The evidence, therefore, from these two deposits indicates that the building was constructed in the reign of Hadrian or Antoninus Pius, and this dating was borne out generally by the finds from the soil below what must have been approximately the floor-level of the various rooms. These deposits, although not entirely free from objects even of the third and fourth centuries, were very uniform in character and contained little that was later than the first quarter of the second century.

It is unfortunately impossible to draw any very accurate conclusions as to the date when this building fell into disuse.



Pit 1 when dug had been cut through the dividing wall between 6 and 9 and contained coins belonging to the period 265–348 A.D., so it is evident that the very existence of this wall had been forgotten by the middle of the fourth century, as it is hardly conceivable that the diggers of the pit would have selected a spot where masonry would have been encountered. One other item in connexion with this building will in the future probably give a clue to the date of its destruction. The drainage channel which ran northwards from room 8 was evidently not in use after the building of the fort, as although it was found to continue outside, no arrangements had been made for its passage through or under the north wall, and it therefore follows that this house had probably fallen into disuse before the fort was built. That is to say, the house belonged to the town and not to the fort period of the site. The date of the building of the fort cannot as yet be determined, but that it took place roughly in the fifty years between 275 and 325 A.D. may be assumed with some certainty. This then leaves about 100 or more years for the period between its construction and the time when it was finally abandoned by the Romans.

That the site was occupied during the whole of the fourth century, and extensively so towards its close, is clearly shown by the pottery and coins discovered. The evidence, however, for buildings of that period is extremely slight, and it is probable that they were of wattle and daub or half timber construction, as burnt matter containing fragments of daub showing impressions of wattle was frequently met with at high levels. A rough cobble pavement extended in patches over the rooms 1 to 4, some of the pottery beneath it being of fourth-century date. A thin fragment of flint walling, a small portion of mortar floor and a layer of pebbles were situated about 1 ft. 8 in. below the present surface a little south of the centre of 6, while to the south of this again at about the same level were a few tiles laid flat by the side of a patch of pebble path or floor. At a high level just to the east of pit 1 the remains of a rough oblong tank composed of broken fragments of marble casing were met with, the bottom being composed of one slab measuring 19 in. by  $24\frac{1}{2}$  in. and  $1\frac{1}{2}$  in. thick with a  $\frac{3}{4}$  in. chamfer on the lower edge (pl. VII, fig. 2). This slab had apparently been subjected to great heat, and was in consequence in a very friable condition, breaking, when touched, into a number of small pieces. It was, however, of interest, as inscribed across the centre in roughly cut characters 2 in. high was /┐IIII LIII. The distance between the centres of these two numerals is about 9 in., and although it is possible that they formed part of an inscription, the slab being incomplete on three sides, it should be

noted that there is no indication of other letters above, below, or after them. A suggestion made that these numerals may be the numbers of seats in an amphitheatre or similar building is not impossible, but whatever their meaning they were obviously cut on a re-used piece of marble and had no connexion with the building of which this slab originally formed part.

Two exploratory trenches were dug from the west side of site 1 in a north-westerly direction up to the inner face of the north wall of the fort, but no structural remains with the exception of site 2 were encountered. This consisted of a hexagonal structure measuring over all 7 ft. 4 in. by 6 ft. 6 in., the walls being built up in tiles and mortar (pls. VII, fig. 1, and XXXIII). Each of the six outer faces formed a curved niche, and the whole of the exterior was coated with a layer of pink plaster some  $\frac{3}{4}$  in. thick. The interior, also hexagonal and measuring 3 ft. 2 in. by 2 ft., was coated with a pink plaster of very hard consistency, and sufficient remained of the floor to show that it had been formed of the same material. The foundation was of loose stones and cobbles 2 ft. 6 in. deep, upon which was a layer of tiles set in mortar, forming a level bed for the structure above. The north and south niches had been subsequently filled in with rough masonry brought to a straight face and plastered, suggesting that these sides which already had the thickest walls needed strengthening to carry some superstructure. On the east side a chase had been cut through the wall down to the floor level of the interior, and it is possible that there was a lead outlet pipe at this point, the masonry being cut through when the structure fell into disuse in order to obtain the metal. No exactly similar structure can be found recorded, but it was clearly built to contain water, and may have been a tank or fountain which served solely as a pleasing feature in a garden of one of the houses. Against this, however, must be set the fact that it was less than a foot beneath the present surface, and that all the objects found in the vicinity at about its original ground-level belonged to the latter part of the occupation of the site. This suggests that it was not built until after the fort, within which there were presumably no houses with gardens. A human skull<sup>1</sup> was found within a few feet of this structure at about its original ground-level, while a layer some two to three inches thick entirely composed of small fish bones was met with close by.

At the point marked X on pl. XXXII one of the exploratory trenches was carried up to the north wall of the fort, which was

<sup>1</sup> Professor Parsons, F.S.A., who examined this skull, states that it is that of a child of about seven or eight years of age, with an index of 783, and from its facial characteristics he believes it to be of Nordic ancestry.

found to be in an excellent state of preservation, standing some eight feet high below the present surface-level. Its facing was still intact and the trowel marks could be seen on the pointing, which on the lower portion of the wall still remained practically in the same condition as when executed by the Roman masons. The photograph (pl. vi) and the drawing (pl. xxxiii) give a better idea of its construction than any written description.

Pits 2, 8, 9, 10, 12 and well 3 were met with in digging these two exploratory trenches. Pit 2 was sunk to a depth of 22 ft. 6 in., the bottom 8 ft. 6 in. being 4 ft. square with slight traces of an original wood lining. The upper part of the shaft was roughly circular with a diameter of 7 ft. at the top, and it seems probable that in the first instance this pit was square for its whole depth, and that subsequently the sides of the upper part caved in. The filling down to ten to twelve feet from the bottom was mostly of second-century date, but below that the pottery belonged to the period 80-110 A.D., while near the bottom was a coin of Claudius I and a stamp of Licinus (P. no. 36 (A)); it is therefore possible that this pit was open in the middle of the first century. Directly over the pit at 2 ft. from the present surface the sculptured slab (p. 37) was found lying face downwards. Pit 8 had been sunk to a depth of 27 ft. and was 3 ft. in diameter. Down to 16 ft. the filling contained pottery of the late first and of the second century, the next 4 ft. late first century, while near the bottom was a fragment of form 29 (pl. xviii, no. 7). Pit 9 was 7 ft. by 3 ft. 10 in. and 8 ft. deep, containing only a few fragments of pottery mostly of the first century. Pit 10 was 4 ft. 6 in. by 5 ft. 6 in. and 9 ft. 6 in. deep; it contained a mixed collection of pottery of which the greater part belonged to the late first century. Pit 12 was 27 ft. 6 in. deep and 3 ft. in diameter. A few fragments of late pottery came from the top of the filling of this pit, but otherwise it contained nothing later than the early years of the second century, the greater part being of the first century. A coin of Trajan, 98-117 A.D., was found at 13 ft., and one of Vespasian, 71-73 A.D., at 17 ft. 8 in. Well 3 was 25 ft. deep and 3 ft. 6 in. in diameter. A very small amount of pottery, none of it later than about 100 A.D., was found in the filling.

Wells 1 and 2 and pits 11 and 14 have already been mentioned in connexion with the building on site 1. Well 1 (pp. 12 and 17) was 3 ft. 6 in. in diameter and 30 ft. deep. Well 2 (p. 13) was 3 ft. 4 in. in diameter, but its depth could not be determined as the sides began to fall in after it had been cleared to some 25 ft. Pit 11 (p. 17) was 3 ft. 3 in. in diameter and 31 ft. deep. Pit 14 (p. 11) was 3 ft. 6 in. in diameter and 28 ft. deep. Near the

mouth was the stamp SALVE on Hof. 4 A, three fragments of Hof. 7, the coarse ware vessel type 2, the mouth of an amphora, and part of a lid. In the filling mostly between 18 to 23 ft. down, below which practically nothing was found, were the following :—

Decorated Samian, form 29, pl. xvii, nos. 1 and 2.

Plain Samian. Hof. 1, one nearly complete. Hof. 2 B, three fragments of one bowl. Hof. 3 B, one fragment. Hof. 4 A and B, many fragments. Hof. 6, one complete, and three fragments. Hof. 7, many fragments. Hof. 9 B, one complete.

Stamps on plain Samian. BASSI on Hof. 6. BVCCIO/ on Hof. 1. OFLICIN on Hof. 1. OF.MASCL on Hof. 6. OMOM on Hof. 9 A.

Amphora stamp P.C.C. on a large round-bodied example (p. 85).

Coarse wares, types 1 and 3 to 20.

All the Samian forms from this pit are of similar types to those found in the early fort at Hofheim 40–51 A.D., and stamps of four out of the six potters also occur on that site, while several of the coarse ware examples are of such a pronounced Late-Celtic character that, had they not been found associated with the Samian, they might well have been assigned to the period immediately preceding the Roman occupation. There can be little doubt that this pit was filled in during the reign of the emperor Claudius, that is between the date of the invasion in 43 A.D. and his death in 54 A.D.

Pit 13 opposite the south end of the dividing wall between 6 and 9 was 32 ft. deep and 3 ft. 3 in. in diameter. A large quantity of pottery mostly of the first and early second centuries came from this pit, the stamp OF.RVFINI (P. no. 54 (A)) being found at 20 ft. down. A coin of Vespasian 71–73 A.D. and one of Trajan 98–117 A.D. came from 13 ft. 6 in. down, and at 14 ft. 9 in. were two more, probably of the latter emperor, while at 29 ft. were two very corroded examples, one of which may be assigned to Claudius I with some certainty. It would seem likely therefore that this pit may also have been open before the last quarter of the first century.

Pit 5 was on the south side of the main east-and-west road. It was 10 ft. 6 in. deep, 3 ft. 6 in. in diameter, and the majority of finds from it, which included a number of fragments of imitation Samian, may be assigned to the fourth century (p. 91).

Pit 1 (p. 18) was of very irregular shape, some 5 to 6 ft. in diameter at the top and sunk in the soil to about the same depth. It contained coins of Victorinus 265–267, Claudius Gothicus 268–270, Galerius 305–311, Constantine 320–324, Constans or Constantius II 342–348, and three illegible coins

not earlier than 260 A.D. The pottery from this pit was mostly of fourth-century type (p. 91).

Pit 7, situated near the western side of the large concrete foundation, was of unusual character. For 15 ft. 6 in. from the present surface-level it had a diameter of 11 ft., but at this depth a shaft 4 ft. 3 in. square, bordered by a thin layer of brown matter, apparently the remains of a wooden lining, appeared in the centre, and this was cleared to 30 ft. when the sides began to fall in. It was eventually found that the circular and the square shafts had both continued down to a depth of 34 ft., the space between them being packed with sand except at the bottom where gravel had been used. Water came into the bottom as quickly as it could be baled out, and at this point a portion of timber framing was still in position and well preserved, consisting of four 10 to 12 in. timbers halved together so that their upper surfaces were level (pl. xi). On these were spiked the fragmentary remains of smaller timbers set back some 3 in. from the inner face of the timbers below, thus forming a rebate. There was no woodwork remaining above this point, and it was impossible to ascertain the exact construction of the lining of the well or the method of its fixture. It should be noted that when the water-level was reached, the sand in which the well was sunk became practically running sand, and it would seem that, unless some precaution were taken to prevent this from rising in the shaft, there would hardly have been a sufficient head of water to ensure a constant and clean supply. It is therefore conceivable that some form of strainer may have been attached to the framing so as to overcome this difficulty, thus providing a possible explanation for the presence of the rebate.

As already stated, there were no remains of the actual wooden lining of this well except a thin line of brown matter, obviously decomposed wood, but it is possible that it may have been of similar type to that of a well of the Claudian period found at Margidunum (*J. R. S.*, vol. xiii, p. 117). The shaft in this instance was 5 ft. in diameter with a rectangular wooden lining 2 ft. by 1 ft. 6 in., the space between the two being filled with rammed clay. The lining itself consisted of wooden uprights at the angles held together by flat timbers mortised into them some 10 in. to 12 in. from the top and bottom. On the outer faces of these horizontal timbers vertical planks were placed to hold the clay filling in position.

In the first instance the square shaft in pit 7 must have continued up to the ground-level, and at some subsequent date the upper part of the filling surrounding it caved in, blocking the lower part of

the square shaft but leaving the sides of the upper part of the circular shaft exposed, thus forming a large cavity in the soil which was subsequently used as a rubbish pit. Much building refuse, including many pieces of broken marble casing, and a fragment of a large bronze statue were deposited in it, as well as part of a fluted stone column and two large blocks of oolite measuring respectively 6 ft. by 3 ft. 6 in. by 2 ft. and 4 ft. 10 in. by 2 ft. 4 in. by 1 ft. 5 in., both having lewis and dowel holes. Practically nothing was found in the lower part of the square shaft down to the 30 ft. level, and after the filling surrounding it fell in, all stratification was destroyed, but a few fragments of first-century pottery and a potter's stamp of that date were recovered, and it is possible that this pit or well was sunk before 100 A. D. The only articles found actually at the bottom were a leather shoe and a small bronze object, apparently part of a bit. The following coins came from this pit :—

At 10 ft. from the surface.

	Two unidentifiable but of the period	. 363-378
	Three ditto . . . . .	. 250-300
	Tetricus I . . . . .	. c. 270
„ 15 ft. 3 in.	Radiate crown type . . . . .	. c. 260-300
„ 15 ft. 8 in.	Claudius Gothicus . . . . .	. 268-270
„ 16 ft.	Radiate crown type . . . . .	. c. 260-300
„ 16 ft. 3 in.	ditto . . . . .	„
	Two Victorinus . . . . .	. 265-267
	Diocletian . . . . .	. 284-305
	Tetricus I . . . . .	. c. 270
„ 18 ft.	Radiate crown . . . . .	. c. 260-300
	Gallienus . . . . .	. c. 260-268
	Tetricus I . . . . .	. c. 270
„ 20 ft.	Radiate crown type . . . . .	. c. 260-300
„ 22 ft.	ditto . . . . .	„
„ 23 ft.	ditto . . . . .	„
„ 23 ft. 6 in.	Tetricus I . . . . .	. c. 270

Fragments of others and several illegible examples were also found at various levels, and as far as could be ascertained were of the same period as the majority of those enumerated above.

If the two coins from the 10 ft. level be omitted as having been probably introduced into the mouth of the pit at a later date, it will be seen that the coin evidence points very conclusively to the filling having been deposited after 285 A. D. but before the end of the first decade of the fourth century. The presence of the numerous fragments of marble casing, the two large blocks

of oolite, etc., which can hardly have come from any other structure but that on the great concrete foundation close at hand, indicates that this building must have been in a ruinous state at that time. The fact that two human skulls<sup>1</sup> should have been found with this building rubbish strongly suggests that the filling represents a clearing up of the site after some disaster, and it is tempting to suppose that this was being done at the time when the erection of the fort was contemplated or when it was actually being constructed.

It will be seen that several of the pits and wells were sunk to a depth of 27 to 34 ft. and averaged from 3 to 4 ft. in diameter. Only in two instances, both where the shafts were of square section, was there any trace of a wooden lining, but in several of the circular examples there were slight indications that the sides had been coated with a layer of puddled clay. In several cases small recesses were noticed cut at intervals in the sides of the shafts, and it is possible that these may have been used by the sinkers for footholds when ascending and descending. Although several of these deep shafts of small diameter have been termed pits, it is highly probable that in the first instance they were wells, the bottom being generally very moist, while water was actually encountered in some of the deepest. It is also more than likely that the water-level was higher in Roman times, which would account for some of them now being dry. That there were so many wells within a small area may be explained by the fact that they were sunk in comparatively soft sand causing them to silt up easily and become useless. When this happened they would naturally serve as convenient places for the disposal of rubbish.

One other point in connexion with these deep shafts is worthy of note, namely, that the majority of them were filled up during or shortly after the reign of Trajan, which would seem to denote some change in the occupation or lay-out of the site at that time. If the assumption that the area under review was occupied at about the end of the first century or the beginning of the second by artisans employed on the construction of the building on the large concrete foundation is correct, a reason for this is at once apparent, as the work having been completed, their workshops, etc., would be removed and the vicinity of the building generally tidied up and levelled.

<sup>1</sup> Professor Parsons reports that one of these skulls is that of a male adult over forty years of age with a cranial index of 745, as far as can be judged from its damaged condition. This is about the normal Saxon index, and the skull is therefore as likely to be Saxon as anything else.

The second skull was that of a child of about eleven years of age with an index of 791. From the facial characteristics it would appear to be of Nordic ancestry.

## ROAD SECTIONS

As already stated, site 1 was situated in the angle formed by two roads, one running roughly east and west and the other north and south. The former of these led to the west gate of the fort, and was probably the main road of the town and also of the later fort. The latter has not yet been fully explored, but its direction is towards the postern gate in the north wall of the fort. Six cuts were made across or into these roads, and the sections obtained are given on pl. xxxiv.

Section 5, cut across the east and west road from the early low-level wall in front of site 1 to the southern edge of the road, showed that the first metalling of the roadway itself was composed of small rounded pebbles tightly rammed. This was 26 ft. in width and 10 in. thick in the centre. On the north side and slightly overlying it was a layer of disintegrated tufa, 6 ft. 3 in. wide, and joining it and extending northwards to the low-level wall was a thin layer of pebbles. This layer also extended some distance to the north of this wall. The roadway itself had been re-metalled twice with the same small rounded pebbles tightly rammed, but although both these re-metallings were of about the same thickness as the original road, neither of them extended to the same width. There was no mixed soil or rubbish between these layers, and together they formed a road of very solid consistency, some 3 ft. thick in the centre. On the north side of the third metalling, and extending down to the edge of the second, was a pocket of burnt matter and rubbish containing some fragments of wall plaster. The fourth and last remaking of the road was separated from the third by a layer of mixed soil and was of an entirely different character to the others, being of poor quality and composed of stones of various sizes mixed with much broken and disintegrated oolite. This oolite,<sup>1</sup> of which a great quantity was found at high levels in the vicinity of the large concrete foundation, must undoubtedly have been used in the construction of the building that originally stood upon it. It therefore follows that this last road metalling, largely formed of this material, must have been laid down after that building had fallen into a state of decay. This fourth road, some 26 ft. broad, had a distinct dip 2 ft. across in the centre, where a drain or gutter may have originally been situated. On its northern side the metalling continued in a thin layer to about the line of the high-level wall in front of site 1.

<sup>1</sup> Samples of this oolite have been submitted to the Geological Survey experts, who state that it comes from the quarries at Marquise near Boulogne.



Another cut (section 6) was also made into this road a little to the west, but was not carried right across it. The three layers of rammed pebbles and the pocket of burnt matter were found to coincide very closely with those in the last section, but here the burnt matter continued northwards for some distance in a layer varying from 3 to 9 in. thick. The fourth road-metalling was however of a different material, being mostly composed of a rich yellow gravel probably obtained from one of the gravel beds in the neighbourhood. The portion of this layer immediately abutting the wall in front of site 1 was made up of pebbles and flints. This wall was built upon a thin layer of small pebbles—probably a pathway—which had underlying it a band of burnt matter. Over the wall, and extending 17 ft. to the south and 5 ft. to the north, was a thin layer of pebbles. In no instance did any of these layers come up to the main wall of site 1.

Section 4 was cut at right angles to the concrete foundation at a point opposite the centre of the west arm of the cruciform block of masonry and roughly on the axis of the low-level east-and-west road. Here the lowest road-metalling was composed of the same tightly-rammed rounded pebbles as in the previous sections, but it diminished in thickness as it approached the concrete foundation, being some 9 in. thick at the point of junction, its surface lying 6 in. below the top of the foundation. There was no evidence of re-metalling in this layer as in the cross-sections farther to the west. Immediately over it was a layer of clean sand with a rubbish layer above that again, both of which extended over the concrete foundation, but how far could not be ascertained as they had been cut through in previous excavations. Above the rubbish layer and separated from it by a band of mixed soil was a layer of pebbles 4 in. thick. The surface of this was about a foot above the top of the foundation, but whether it originally extended over it could not be ascertained as it had also been dug away at this point.

The cut, section 3, made at the intersection of the two roads showed at the eastern end practically the same stratification as section 4, except that the rubbish layer was largely composed of broken oolite. It should also be noticed that the upper edge of the concrete foundation had here a distinct overhang. The low-level metalling, which was about 1 ft. thick where it abutted against the foundation, gradually increased to 2 ft. 3 in. at 15 ft. to the west where it ended abruptly. At this point mixed soil containing broken oolite extended down into the natural soil and westwards over the first two metallings of the north and south road. This curious change in the stratification may possibly be accounted for

if the stone drain shown in section 2, and at about the same distance from the concrete foundation, had originally continued in this direction and been removed later for some reason that is at present obscure.

It will be seen that the first metalling of the north-and-south road, which was some 20 ft. wide and 12 in. thick in the centre, was similar in character to the corresponding one of the east-and-west road, its surface being at approximately the same level. The first re-metalling was also of the same tightly-rammed pebbles, but in this instance some fair-sized shaped and dressed stones were intermixed with them. This re-metalling was only 10 ft. wide and 10 in. thick in the centre. Above it was the layer of soil and oolite already mentioned, capped by a distinct road or path of broken and disintegrated oolite. Above this again, and separated from it by a band of mixed soil, was a rough pebble layer extending to the edge of the concrete foundation, where it had been previously disturbed.

In section 2, cut across the same road about 38 ft. to the north, the low-level road was 5 ft. narrower than in the previous section and abutted against the low-level wall to the west. Overlying its western side was a layer of clean sand apparently thrown on to its surface from some excavation near at hand, possibly from the trench dug for the low-level wall at this point. The first re-metalling, which partly covered this layer of sand, was different in character from the corresponding one in section 3, being entirely composed of small pebbles. The westerly portion of the third road-metalling was of broken and disintegrated oolite which gradually altered to a thin layer of pebbles to the east. This layer rested on the top of the concrete foundation. Above this third surface was a layer of mixed soil, containing at its eastern end a seam of clean sand which carried through over the concrete foundation. The fourth and highest road or path was, as in the last section, formed of a rough thin layer of pebbles which had again been disturbed before it reached the line of the foundation. A massive drain or gutter, its base formed of single stones with curb-stones standing upon them, was met with in this cut, sunk into the natural sand. The sides stood only one course high, and there was nothing to indicate that others had existed. It would in all probability have been covered with stone slabs, which may have been robbed before the laying of the third metalling, as the soil immediately above and on either side of the drain contained many fragments of the broken oolite and was of a like character to the corresponding portion of the last section (no. 3). There was also the same sharp change in the stratification

to the east, although in this case the metalling was absent, a layer of sandy loam taking its place, while at a low level near the face of the concrete foundation a group of irregularly placed stones occurred. It should be noted that none of the metallings 2, 3, or 4 extended over the low-level wall in this cut or up to the east wall of the main building on site 1. No. 3 did, however, definitely oversail the low wall farther to the south, which must have been reduced to its present height before that metalling was laid down. To the west of the low-level wall a layer of pebbles extended under the foundations of the main building on site 1, probably corresponding to a similar layer mentioned under section 5.

Section 1 was cut across the same road in a line with the back wall of site 1. The lowest-level road was of a similar character to that in the last section, but extended farther eastwards. The first re-metalling was thicker than in the previous section and contained a number of large flints and stones in its western portion. Partly underneath it on this side and immediately on the surface of the first road was a thin rubbish layer which ran to the foundations of the east wall of the main building on site 1. A band of clean sand covered this rubbish layer where it extended beyond the road metalling. On the east side another layer of sand separated the first metalling from the second. The third metalling, formed of small pebbles and not of broken oolite as in sections 2 and 3, rested immediately on the surface of the second. There was no trace at this point of a fourth metalling as in the two previous sections, but a thin cobble layer, which may have represented a path, abutted against the wall of the main building on site 1 and extended eastwards some 7 ft.

It was thought probable that this north-and-south road would have continued to the postern gate in the north wall of the fort, and a trench was cut, as indicated on pl. xxxii, to the south of the gate in order to obtain a section at that point, but no certain indications of a road or path were encountered.

Most unfortunately, little useful dating evidence was forthcoming from these sections. A few fragments of pottery were found beneath the first road metallings, but in no instance could any of them be dated more closely than to the first century A.D. The first three metallings of the main road contained nothing whatever, nor was there any deposit of rubbish on the first or second surfaces. In section 5, however, a coin of Claudius I, 41-54 A.D., was found near the surface of the first road on its northern side. The pottery from the second road layer in section 2 belonged to the last quarter of the first century, and that from

below the top road in the same section did not appear to be later than the second half of the third century. In section 4 a coin of Valerianus, 257 A.D., was found beneath the top road metalling.

Pottery, etc., was naturally found in considerable quantities by the sides of the roads and beneath the top road or path levels, but the soil had been so disturbed, both in Roman and post-Roman times, and the highest-level roads and paths had so often been broken through, that the dating evidence from these deposits was of such an uncertain and conflicting character that no conclusions could be drawn from it. That the first three road metallings of the main east-and-west road belonged to the town period, and the rough upper ones were of the time of the fort may, however, be assumed with some confidence. The evidence afforded by the fact that the low-level road abutted against the concrete foundation (sections 3 and 4) may be read in two ways, either that the road had been cut through and sloped down towards the foundation when that was constructed, or that it had been carried up to the face of the foundation after it had been built. If the latter was the case it is difficult to understand why the road should have sloped towards the foundation, but on the other hand the road metalling differs from that found in section 5 farther to the west, as it appears to have been laid to its full depth at one time and not in three separate metallings, which suggests that it is not a direct continuation of the main east-and-west road. An explanation of this will, it is hoped, be supplied by further excavation.

The first two metallings of the north-and-south road are somewhat similar to the corresponding ones in the east-and-west road, but the third is of an entirely different composition, while the fourth, although present in sections 2 and 3, is absent in section 1.

In section 6 there is a fifth layer of cobbles, etc., on the north side of the road, probably representing a path or cobbled area, which does not occur in any of the other sections.

#### OTHER RECENT DISCOVERIES

During the last few years the Office of Works has been engaged in gradually tidying up the site and making some of the features of the fort more intelligible for visitors, and it will be as well to incorporate in this report the results of these operations.

The remains of the main gate in the west wall, which had previously been partly uncovered, were entirely excavated and left

open. A plan of the gate and a section through it are given on plate xxxv. The fact that this gate had been built of large blocks of stone (pl. 1, fig. 2), which in a district where stone is scarce would be of considerable value, undoubtedly accounts for the greater part having disappeared, and several blocks of stone similar to those still *in situ* can be seen in the farm buildings near at hand. This robbing of the stone and previous excavations had left what remained in a most deplorable and disturbed condition, but by careful investigation it was found possible to ascertain the original plan. The whole structure measured some 35 ft. north and south and 25 ft. east and west, projecting a little over 6 ft. from the outer face of the main wall and 8 ft. from the inner. The remains of the southern flanking turret are the best preserved, and in the section on pl. xxxv it will be seen that the two bottom courses are composed of blocks of stone 1 ft. 6 in. high, the third—the top course remaining—being 1 ft. 8 in. The second course oversailed the lowest by some 5 in., and in places where the stones were not of sufficient size to provide for this projection it had been made up in mortar. All the blocks of stone appear to be re-used material from some other structure, and in several instances had been roughly cut or chamfered to make them fit. The whole work is very irregular and patchy, considerable gaps between some of the stones having been filled in with mortar containing fair-sized fragments of tiles, flints, and broken stone. The masonry is bonded into the wall of the fort and there can be little doubt that the turret and wall are one build. The bottom three feet, which are in some places composed of two courses and in others of three, appear to have served simply as foundation, there being an offset of some 4 to 6 in. above the second or third course as the case may be. The only actual remains of the walls of the turret are represented by the top remaining course, of which a portion exists at the south-east angle. From this it appears that the south wall was only one stone thick with an average width of 2 ft., the setting-out line for its inner face still being discernible on the top of the foundation course, as shown on the plan (pl. xxxv), while the east wall was two stones in thickness with a width of 3 ft. 6 in. A slight chamfer worked upon the top of the foundation course and indicated on the plan represents the line of junction between the east and north walls, the latter being obviously of the two-stone thickness (3 ft. 6 in.). Nothing of the west wall remained, but it was probably of the same width. The internal measurements of the chamber formed by these walls would have been approximately 16 ft. 6 in. by 7 ft. 9 in., and access must have been obtained

to it from the entrance passage, as there was no indication of a doorway in the eastern wall. Of the north turret little remained except a few blocks of stone irregularly set in hard mortar. The foundations of the fort wall carried on under this turret, the stone blocks having been set on them. Outside the line of these foundations to the east and west the projecting portions of the turret had been built on a layer of stones and flints. It was found possible to determine roughly from these foundations, and by the edges of the existing road-metalling that must originally have abutted against the turret, that it was of approximately the same size as the southern turret. The actual entrance-way through which the road passed would therefore have been about 11 ft. across, and it is obvious that this gateway had a single arched entrance flanked by two oblong turrets. These turrets probably carried up higher than the top of the wall of the fort and contained several stories, the ground floors being used as guard-rooms. It is probable that the door itself was situated in the passage-way about in a line with the outer face of the fort wall, and the gap in the northern face of the remains of the south turret was possibly caused by the robbing of the foundation of the projecting door-jamb. The early fourth-century fort at Alzei,<sup>1</sup> 30 km. south-west of Mainz, which in plan is almost identical with Richborough, had gateways of similar form, and, as this is not the ordinary type found in earlier forts, we have here another piece of evidence that the fort at Richborough was built at a date not far removed from the year 300 A. D.

An interesting discovery was made when clearing the eastern face of the south turret, namely, that an earlier road was cut into when its foundations were laid down. The outline of this road, which was not traced to its full width towards the south, is indicated on pl. xxxv, and there can be little doubt that it is a direct continuation of the low-level metallings found in front of site 1, and illustrated on pl. xxxiv, section 5. It was made up of the same tightly-rammed pebbles and was also about 3 ft. to 3 ft. 6 in. thick in the centre, which corresponds very closely to the combined thickness of the first three metallings in section 5. The same series of metallings was not noticed in the road at the gateway, but that they may have been present is quite possible, as even in the very excellent section that was obtained in front of site 1 they were extremely difficult to discern.

A layer of the rounded pebbles appeared to extend under the

<sup>1</sup> Das Kastell Alzei, *Bonner Jahrbücher*, 122, p. 136.

lowest course of this turret, and it would seem that the earlier road had not been cut through to its entire depth, but that this layer had been left, possibly as a bed or foundation for the masonry. That the gate should not have been built with the axis of this road passing through it centrally is curious, and it would almost seem that the builders of the fort did not know of its existence, though this would hardly appear possible. The solution to this will, however, probably be found in the course of the excavations, but it is of value to know that this road is of pre-fort date and must therefore belong to the town period of the site, as was suggested on page 29.

Two cuts were made across the road in the entrance passage, the main features of the stratification coinciding very closely in both, but it was found extremely difficult to obtain much useful data, owing to the considerable disturbance caused by previous excavation and digging for stone.

A section obtained from one of these cuts is illustrated on pl. xxxv, from which it will be seen that there was a layer of small pebbles on the surface of the natural soil which continued under the south turret but did not run farther northwards than the presumed southern edge of the north turret. It is possible that this corresponds to the first road metalling in section 5, pl. xxxiv. In it was a stamp of Celsus (P. no. 14 (A) Claudian). Over this was a narrow irregular band of rubbish containing pottery apparently not later than about 75-85 A.D. Above this, and at a point about 2 ft. from the north turret, was a layer of tightly-packed small pebbles which extended to the face of the south turret. The surface of this layer sloped upwards from north to south, and although a portion had been cut away by previous digging it must undoubtedly have been the northern camber of the pre-gateway road. It is possible, therefore, that the next road-surface may have been that of the gateway itself, but it was only represented by a small portion of metalling on the northern side, which may well have been only the remains of a path by the side of the pre-gateway road. It will be seen that there was a pocket of mixed soil 3 ft. 6 in. wide by 1 ft. 6 in. deep in the centre of the entrance and cutting into the pre-gateway road. This pocket or trench of mixed soil occurred in both sections as well as to the east of the gate, and can only represent the position of a drain, probably of wood, passing through the centre of the entrance passage and under the fourth road-metalling, which undoubtedly belonged to the fort-period. This metalling was composed of larger flints and stones than the earlier road, and was of a much rougher character, but little of it remained owing to previous

disturbance at this point. The following coins were found near the surface of the top road :—

Tetricus I . . . . .	268-273
Constantine I . . . . .	330-337
Theodosius . . . . .	379-395
Arcadius . . . . .	388-395
House of Theodosius . . .	388-395

Just to the east of the gate there was evidence of two more rough road metallings. One was some eight inches higher than the level of the top road surface shown on pl. xxxv, while the other was ten inches above this again. Both of these would presumably also have passed through the entrance, but whether they were of Roman or later date can only be ascertained by further excavation.

At a point where the south wall of the fort now ends abruptly and almost opposite the postern in the north wall, work was carried out to ascertain if a turret or gate had also existed on this side (pl. xxxi). It was found that the fort wall ended here in a ragged face (pl. iv, fig. 2 (A)) and had been entirely destroyed to the foundations, no masonry being met with *in situ* to the limit of the area explored eastwards. Excavation at this point was considerably hampered by masses of fallen masonry, some of which appeared to be portions of a projecting turret rather than of the wall itself. Slight indications that some structure projected from the face of the wall were also met with at a low level, patches of chalk and cobble foundations being found running at right angles southwards from the line of the wall a little to the east of its ragged end. These extended for some 10 ft. and then returned eastwards, dying out after continuing only for a few feet. Immediately on the outer side of these patches of foundation, that is to the west and south, the natural soil rose sharply some 1 ft. 6 in., and there can be little doubt that it was dug out to this depth when these foundations were laid down. No similar traces of foundations could be found running out from the line of the fort wall farther to the east, but at a point some 28 ft. from the broken end of this wall a cobble pavement was discovered. This pavement extended southwards from the line of the fort wall and eastwards to the limits of the excavation, and was some 2 ft. above the natural soil level. It may be assumed that these patches of foundations denote a rectangular masonry structure projecting some 10 ft. from the face of the wall; and that it did not exceed 28 ft. in width and may possibly have been less is shown by the presence of the cobble pavement to the east,



which also indicates that there was probably an entrance at this point.

From the scanty remains found it is not possible to determine with certainty the actual size or purpose of this projection, but it is reasonable to infer that it was similar to the postern turret in the north wall, which projects 10 ft. 7 in. and is 21 ft. 3 in. wide, with an entrance in its eastern face.

The outer face of the south wall and of the west wall from the south-west angle to the main gate was cleared of soil down to the offset above the foundations and has been left exposed, thus greatly adding to the height and appearance of the walls, on which the Roman pointing was in places still intact, the trowel marks being as fresh as on the day the work was completed (pl. VIII, fig. 2).

The remains of a rectangular turret on each of these stretches of wall and a circular one at the angle were also uncovered, and found to be standing several courses high. The turret on the south wall projected 10 ft. 5 in. on the west side and 9 ft. 10 in. on the east, being 20 ft. 5 in. wide, and that on the west wall projected 10 ft. 4 in. on the north side and 10 ft. 9 in. on the south, with a width of 20 ft. 4 in., while the angle turret was 18 ft. 6 in. in diameter. The corresponding circular turret at the north-west angle was also examined and proved to be 6 in. less in diameter, while the turret between it and the west gate projected 10 ft. 9 in. on the north and 9 ft. 9 in. on the south, being 19 ft. wide; neither of these could be left open as a farm track passes over them. The position of the turret between the north-west angle and the postern-gate had already been determined: it measured 10 ft. 9 in. on the west side, 9 ft. 9 in. on the east, and was 19 ft. 3 in. wide. No trace could be found of the foundations of the turret situated to the east of the postern, but the position where its walls bonded into the main wall of the fort can be clearly seen, its width having been 19 ft. 10 in.

The only item of interest found in clearing these turrets was a patch of cobble pavement on the west side of the one on the south wall. This was situated about 4 ft. from the turret and 6 ft. from the fort wall, and was covered by 2 ft. of soil. Immediately under it was a burnt layer 9 in. thick in which were five coins, *c.* 260–296 A. D., and below this again was a layer of building rubbish 3 in. deep. Only the edge of this pavement, which extended farther south, was examined.

Efforts were made to trace the line of the north wall eastwards down the slope of the bank but without result, no trace of even the foundations being met with, although the large masses of fallen

masonry to the north are sufficient evidence that it originally extended in this direction. Trenches were also dug across the ground at the foot of the slope on the east of the site, and fragmentary patches of cobbles and chalk were discovered, marked 'footings' on pl. xxxi. They were, however, very irregular and sloped at various angles towards the east, being obviously not in their original position. Just beyond these to the east is a line of fallen masonry<sup>1</sup>, all that now remains of the east wall of the fort, and there can be little doubt that a landslide must have taken place on this side as the result of erosion caused by the action of the river or sea. That this east wall had circular turrets at the angles and rectangular ones projecting from its face, as on the other walls of the fort, may be taken for granted, but whether or no there was a similar gate to that in the west wall or a postern as in the north wall cannot be determined.

### THE MARBLE CASING

Fragments of the marble casing of some important building, probably the structure that stood on the great concrete foundation, were found in large quantities, the majority being parts of flat slabs. There were also, however, many moulded pieces, but it is not intended at this stage of the excavations to describe them in detail, as many more will undoubtedly be found in the future, and a report at a later date, when enough material has been collected to make an approximate reconstruction of the building possible, will be of much greater value. The proportions of this structure can, however, now be estimated, as the fragments of the column casing show that the shafts were some 5 ft. in diameter—that is to say, about the same as those of the portico of the British Museum. It will be useful here, however, to record the evidence that has been obtained for the date when this marble was first brought to the site.

Several pieces occurred in the filling of pit 2 below the 14 ft. level in connexion with pottery of A.D. 80-100. In well 3 was a baluster moulding with pottery of the late first century. At a low level under the north-east part of 6 in site 1 was a thin layer of mortar containing sixty-four fragments of marble, some moulded, the datable finds with them belonging to the period 85-110 A.D. A little farther to the south, in a deposit

<sup>1</sup> A cut 14 ft. deep was made at the western side of this fallen masonry, and at that depth a few scraps of medieval pottery were found. This accumulation of earth may have been caused by the soil from previous excavations having been tipped over the bank at this point.

assigned to 80-120 A.D. were two more pieces, while under the corridor others were found with objects that might be earlier than 80 A.D. Not far south of well 2 and practically on the natural soil was a small heap of what appeared to be masons' chippings; nothing datable was found with them, but their position indicates that they must have been deposited at an early date. The evidence then clearly shows that the marble casing was present on the site by a date not far removed from 100 A.D. This marble, which is known as Luna marble, was brought to this country from Tuscany, and some would in all probability have been broken in transit, thus becoming unsuitable for the purpose for which it was intended, and would therefore have been discarded. Also, although the quality of the work implies that it was imported in a worked state, a certain amount of cutting must have taken place on the spot, which would have produced numerous fragments, and it may be assumed that it is the masons' chippings and discarded pieces that are now being found in these early deposits. It is possible, although not likely, that these fragments may have been lying about the site for many years before getting into the deposits in which they were discovered, and it is therefore unwise to attempt to fix a date for the marble-cased building from them until much more digging has been undertaken, although that it was early in the history of the site is now certain. It should be noted, however, how closely the date of the appearance of this marble coincides with that of the suggested occupation of this part of the site by artisans employed on the erection of the building on the great concrete foundation (pp. 6 and 7).

When this building fell into decay is as yet not so easy to determine. The majority of the marble was found at levels which suggest its deposit after the main building on site 1 had ceased to exist, and the presence of several moulded pieces in the walls of the fort (pl. VIII, fig. 1) indicates, although it does not prove, that the marble-cased structure had fallen into a state of decay before the building of the fort. The filling of pit 7, which contained numerous fragments (p. 22) and can be dated with some accuracy between 285-305 A.D., supplies us with a date when this building can at the best have been little more than a ruin.

It is interesting to note that marble casing of a similar character has been found in London and Colchester, and may be seen in the museum of the latter place and in the British Museum.

## THE SCULPTURED SLAB

## Pl. IX

This sculptured slab was found at a depth of 2 ft. 6 in. lying face downwards and immediately over the mouth of pit 2. The quality and execution of the relief are exceptionally good for provincial workmanship, and it is undoubtedly one of the finest examples of Roman sculpture that has been found in this country. It has, however, suffered greatly, the head of the figure having entirely disappeared, as have also both the hands and all trace of whatever they may have contained. The back is worn so smooth as almost to appear polished in places, and it is probable that it was re-used in Roman times as a step or part of a threshold or pavement.

It stands 4 ft. 2 in. high, and although the actual top of the stone is missing, the original height cannot have much exceeded this. In width it is 2 ft. 2 in. and its present greatest depth, measuring from the back of the stone to the front of the figure itself, is about 1 ft. 2 in. The remains of the decoration on the side is 10 in. across, and as the panel of imbricated leaves was apparently about 6 in. wide and the missing portion to the right of it probably had mouldings similar to those on the left, the total depth of the sides would also have been about 1 ft. 2 in.

The stone is an oolite which may have come from the quarries of Marquise near Boulogne.

The following report upon this slab has been drawn up by Mr. F. N. Pryce, F.S.A., of the British Museum :

The slab is sculptured on the front and on both sides. The sides are identical, having on the back edge a vertical strip of twisted cord pattern between straight mouldings standing on a moulded base. This twisted band, with a plain moulding on either side, continues as high as can be traced, but on the inner side is a second moulding terminating in a small capital from which springs an arch. It is probable that these mouldings also occurred on the outer edge, the space between forming an arcade filled with imbricated leaves in two panels separated by an ornamental band perhaps reminiscent of a floral garland. The leaves in the two panels are opposed, pointing inwards.

In the front is an arched recess also bordered by pilasters, of which only part of one base now remains. All these architectural details are not uncommon in north Gaulish sculpture of the Roman period ; compare especially the sepulchral monuments

from the Moselle valley (Espérandieu, *Recueil général des Bas-reliefs de la Gaule Romaine*, vi, pp. 317-406).

On the other hand, the figure sculptured in the recess shows no trace of provincial style or craftsmanship. To find the pedigree of this graceful lady we must go to the Hellenized art of the imperial capital and beyond that again to the great age of sculpture in Athens. A woman of slender build and on a scale of more than half life-size stands facing full to the front, the right leg slightly bent; the forearms seem to have been extended holding some attribute, but are now missing. She is fully draped in a long Ionic *chiton* with buttoned sleeves, and a *himation* is thrown about her waist, the fold passing over the left arm. I use the Greek terms *chiton* and *himation* in place of the Roman *stola* and *palla*, because there is nothing distinctively Roman in the conception and details of this figure; it is one of the most widely reproduced types of Graeco-Roman art and must be derived from an original of the closing years of the fifth century B.C. by an Attic sculptor of the school which followed Pheidias and which under the influence of Ionic models produced such works as the balustrade of Athene Nike. This original has disappeared, but is preserved to us in numerous copies, from one of which the Richborough relief is derived; for it is plainly the translation into relief of a statue in the round.

Romano-British sculpture is not generally remarkable for purity of classical taste, and the Richborough relief will rank high amongst the extant traces of such Greek art as found its way to this far-off corner of the empire. When we proceed to consider the purpose of the slab, the identity of the lady, and the date of the monument, we are confronted by its isolated condition when excavated, the loss of head, hands, and attributes, in short its fracture at every point where a clue might have been obtained. Certainty is impossible, but the importance of the find makes it worth while to balance probabilities.

The slab probably stood alone and did not form part of a larger composition. If the back was re-used as a step, as Mr. Bushe-Fox suggests, it was because it was originally a plain flat unsculptured surface; nor is there any trace of a dowel-hole to bind it into a building, and the architecture of the sides suggests a self-contained unit. We may then suppose the relief to have been set up possibly on a separate stone base and perhaps with its back to a wall, and we may restore the missing upper part, on the analogy of a relief in Boulogne (Espérandieu, v, no. 3972) of similar material and dimensions, with a pediment surmounted by acroteria (pl. x, fig. 1). This is a common type of monument in Gaul,

and we may proceed to determine the purpose of the Richborough example.

I. It may be a tombstone, in which case we have a portrait of the defunct. Such grave-reliefs are common; we may instance the Boulogne relief already cited, which though later and more provincial in style, affords a close parallel to our relief: it shows a woman, similarly attired, holding a branch. The Moselle monuments, to which reference has been made, are also sepulchral.

II. On the other hand, the type and ideal treatment of the lady suggest a deity or personification rather than a portrait; and if a deity is intended, the relief was probably a votive offering in a shrine. On looking for deities represented under this sculptural type, we have a wide choice:

(a) she may be Hygeia; right hand holding a snake, left a cup. Compare Reinach, *Répertoire de la Statuaire*, i, 553/1170 B, 556/1184, 557/1181, and ii, 298; also a bronze in the British Museum, no. 1431;

(b) she may be Abundantia; right hand holding cup or patera or flowers, left a cornucopia. Compare Reinach, i, 452/828, 453/830, 456, and ii, pp. 247 ff. *passim*;

(c) with Abundantia, Fortuna is closely allied and the type is used indifferently for either; but if Fortuna is meant, we should expect a trace of the rudder to remain on the lower part of the relief. See Reinach, ii, 261 ff. Into further complications such as Isis-Fortuna we need not venture;

(d) the type is used for other deities, but obvious objections can be raised against other identifications. The figure is not matronly enough for Ceres (as Espérandieu, 5235), or Roma, as on the Arch of Beneventum. A case may be made out for Juno, as Reinach, ii, 241 ff., but Juno more generally is bare-armed; or for a muse as Reinach ii, 306, but it is hard to see why a single muse should occur at Richborough;

(e) that a Celtic or local deity is intended is improbable, given the classical style of the work.

III. There is the possibility that the relief is a portrait of a Julio-Claudian princess perhaps masquerading as a divinity. There are several instances of the type being so employed; see Wyndham, *Leconfield Catalogue*, no. 3 (pl. x, fig. 2), and compare Reinach, i, 935/2380, 918/2342 A, 1915/2464 F, etc.

IV. A suggestion has been made that some symbolical representation is meant, as the Provinces in the Temple of Neptune at Rome (Strong, *Roman Sculpture*, pl. 75). This suggestion would be more attractive if the slab formed part of a series instead of standing alone, as it apparently did.

While none of these possibilities is to be absolutely rejected, it is safest to explain the relief by reference to the wide popularity of the type for representations of Hygeia or Abundantia and to conclude that one of these deities is intended.

Despite its classical style, the relief is a local work of local stone and carved either on the spot or across the Channel. Most Graeco-Roman examples of the type draw the folds of the outer cloak diagonally, whereas our relief makes them more vertical, corresponding with the folds of the under-garment. It does not seem fanciful to see in this the beginning of that tendency to draw the drapery folds in parallel lines which gives a curiously medieval appearance to much Gallo-Roman sculpture—I do not refer to rough work done everywhere with the ruler, but to masterpieces like the relief at Sens (Espérandieu, 2804). Further, the patterns on the side have recalled to us the monuments of the Moselle valley, which provide clear parallels; compare Espérandieu, vi, 5174, 5177, 5183, and the restoration on p. 333. When we consider that these Moselle monuments are especially connected with the shipping and mercantile guilds, members of which must have come across to Richborough at an early date, nothing is more likely than the connexion of our relief with this school of sculpture.

On the other hand, in style and execution there is a wide difference between the Richborough lady and the Moselle sculpture; she is as plainly classical as they are provincial. The Moselle monuments cover the first two centuries of the Christian era; and the style was fully established by the end of the reign of Nero, as we learn from the Jupiter column at Mainz dated by its inscription 66 A.D. (Espérandieu, vi, pp. 377–89; Strong, *Scultura Romana* (1925), p. 98). Now on a comparison of the figures on this monument with our lady, a glance will show how much further from the Hellenic prototypes they are; the proportions squatter, the drapery more formalized—all the spring and lightness missing. Either the Richborough lady is earlier in date than the Mainz column, or it is the work of an artist standing outside the ordinary course of the evolution of sculpture in northern Gaul.

If we accept this second alternative and, neglecting the Mainz column as a dating-point, search elsewhere for a comparison, we still find that the evidence points to an early date. The Boulogne monument already cited (pl. x, fig. 1) may serve us. This reproduces the same type, but obviously is later—some decades later—than the Richborough example. Yet we cannot suppose the Boulogne relief itself to be much later in date than Trajan, so

closely does the head recall such Trajanic types as Hekler, *Greek and Roman Portraits*, pl. 232-236.

The Richborough relief, in fact, stands out clearly from the mass of Gallo-Roman sculptures. If we turn over the pages of the seven large volumes of Espérandieu's corpus it is only rarely that we meet with work which may be compared with it for purity of classical style. Examples are nos. 2346 and 2351; Espérandieu assigns both to the first century A. D. and does not date them more closely, but the first half of the century is obviously more probable than the second half. And if we go for parallels to the art of the capital and Italy, as we are entitled to do in view of the character of the work, we find that it is in the earlier part of the first century, under the Julio-Claudian family, that the taste prevailed for the type represented in our relief, and for the soft grace of the school of sculpture and of the period of Hellenic art whence our relief is ultimately derived.

It will be generally admitted as a superior limit of date that a provincial school of sculpture is most unlikely to have preserved so purely the Hellenic type later than the time of Hadrian, and whatever allowance we may feel disposed to make for a conservative tradition on the part of an individual, it is a question whether a Hadrianic date is not impossible, given the rapid development of the provincial schools. Nor does the relief look Hadrianic: Hadrianic work tends to be stiffer; compare Strong, *Roman Sculpture*, pl. 75, an example of Hadrianic relief, and observe how much closer our relief comes to first-century work as pl. 32; and Hadrianic artists show a preference for the more austere models of a somewhat earlier period.

A date in the first century A. D. seems then indicated for the Richborough lady; and after comparison with the Mainz reliefs of 66 A. D. and remembering that the sculptured type was one which found especial favour in Julio-Claudian times, it may be that we should not go too far down in the century, but have reason to suppose the slab to have been carved and erected soon after the conquest. After all, a work so exceptional in quality is more likely to be early than late; and as the Richborough relief is one of the finest, so it may well be one of the earliest examples of Romano-British sculpture.

To sum up: the relief appears to be a votive offering dedicated by sailors or traders from the Rhineland; it represents a deity of the commercial order, Health or Abundance, or the like, and was set up before 100 A. D., perhaps soon after the conquest of 43 A. D.



## THE PIG OF LEAD

Pl. XI

This partly used pig of lead was found about 1 ft. 6 in. below the top of the walls in room 4, and was therefore under the floor-level of the house. It is hardly possible to believe that an article of this description could have been lost, and it would seem that it must have been buried, possibly after being stolen, and that the hider was never in a position to recover it.

The present length is  $13\frac{1}{16}$  in. but when complete it would probably have been about the size indicated in the illustration. It is  $4\frac{5}{8}$  in. high,  $3\frac{3}{4}$  in. broad on the top, and 6 in. on the bottom. These pigs were formed by pouring the molten lead into moulds which had the inscription on the bottom, and in some instances the lead is in definite layers, indicating that one layer was allowed to cool before another was added.

The Richborough example bears the incomplete inscription IMP · NERVAE · CA . . . in raised letters  $1\frac{1}{8}$  in. high in a sunk panel, and can therefore be dated 96–98 A.D. The AE of Nervae can only be faintly traced, the pig being dented at this point, possibly by another falling upon it.

There are no traces of inscriptions on the sides of the pig such as EXARGENT or DECANGI as there are on some examples, and there is nothing to indicate from which of the British mines it emanated. The principal mines were in North Derbyshire, Somerset, Shropshire, and Flintshire; those of the last county seem to have been most favoured in Flavian times, while a number of pigs of the Hadrianic period come from Shropshire. Over fifty pigs have been found in this country, but this is the only recorded example inscribed with the Emperor Nerva's name, and there is none of his successor Trajan.

See Gowland, *Archaeologia*, vol. lvii, p. 359; *British Museum Guide to the Antiquities of Roman Britain*, pp. 28–31; and M. Besnier, *Rev. Archéol.* 5th ser. xii, 211–44, xiii, 36–76, xiv, 98–121.

## SMALL OBJECTS IN METAL, BONE, ETC.

(Pls. XII–XVI)

1. Bronze brooch with bilateral spring held to the head with loop and covered with two small wings. The catch-plate is pierced with three roughly circular holes. Site 1, room 8, 3 ft. 6 in. from surface. It may be assigned to the first century A.D.

The immediate prototypes of this are to be seen in the La Tène III types in *Swarling Report*, pl. XIII.

Very similar examples have been found at Allington, Kent, and have been dated in the first half of the first century A.D. (*Swarling Report*, pl. xv, 14, 15).

2. Bronze brooch with spring in semi-cylindrical cover. The chord is held by a loop on the head, the bow is convex on the upper side and flat underneath; the catch-plate solid.

Site 1, room 3, in a deposit dated 80-100 A.D.

Several examples of this type were found at Wroxeter, where they were assigned to late first or early second century A.D. (*Wroxeter*, 1914, pl. xv, 6).

Their prototype may be seen in the Late-Celtic examples from Swarling and Deal (*Swarling Report*, pl. XII, 4; pl. XIII, 7, 8, 9). This is one of the commonest first-century types, and those with openwork catch-plates are for the most part early in the series (as *Archaeologia*, lxxi, 193, fig. 29).

3. Bronze brooch of similar type to the last but with more arched bow. Site 1.

4. Bronze brooch with decorated spreading foot, probably originally enamelled. Loop at head and hinged pin. Pit 12, 8 ft. down, in association with pottery none of which was later than the early years of the second century, to which period this brooch probably belongs. A possible prototype from Canterbury is figured in *Antiq. Journ.* iv, 153.

Cf. *Wroxeter*, 1912, fig. 9, 3; Corbridge, *Arch. Aeliana*, 3rd ser., vii, 45; Hook Norton, Oxon., *Proc. Soc. Ant.* xxiii, 407; Brit. Mus. *Guide to Roman Britain*, fig. 71.

5. Bronze brooch. Straight from mould and unfinished.

Pit 2, 12 ft. down, in association with pottery mostly of the second century, though some belonged to the late first century.

6. Bronze brooch enamelled in red and yellow. Site 1.

The same radiating pattern is seen on specimens illustrated by A. Bequet, *La bijouterie chez les Belges sous l'Empire romain, deuxième siècle*, pl. II, nos. 3 (red and blue) and 4 (black and yellow).

7. Circular brooch with conical centre inlaid with enamel, which appears originally to have been dark blue and yellow. Found in the tip from site 1. A type common on Roman sites and generally assigned to the second century A.D. One found at Wroxeter was dated about 100 A.D. (*Wroxeter*, 1912, fig. 10, no. 9), and the type also occurs at Camelon, 80-180 A.D., and

Newstead, 80-180 A. D. (*Proc. Soc. Ant. Scot.*, xxxv, 405, pl. A, and *Newstead*, 331, pl. LXXXIX, fig. 20).

Several references are given in *Archaeologia*, lxxi, p. 192.

8. Bronze enamelled brooch consisting of a disc between two decorative projections. Protruding from the centre of the disc is a crude representation of a bird's head, a feature occasionally found on enamelled brooches of the second century. Site 1. (*Brit. Mus. Guide to Roman Britain*, fig. 73.)

For a complete specimen illustrated in colours see A. Bequet, *op. cit.*, pl. II, no. 4.

9. Bronze cross-bow brooch with hinged pin and a collar on the bow near the foot. The top of the bow and catch-plate are decorated with a row of ring-and-dot pattern. Found near the north wall of the fort in the top soil, and probably belongs to the late third or early fourth century A. D.

Cf. examples from *O. R. L. 6, Holzhausen*, pl. VII, 7, 8, where the latest coin found was Philippus I, c. 247 A. D. *O. R. L. 8, Zugmantel*, p. 70, Abb. 6, fig. 3; latest coin: Constantius II till 361 A. D. *O. R. L. 73, Pfünz*, pl. XII, 83, 84; latest coin: Aurelian, c. 270 A. D. *O. R. L. 40, Osterburken*, pl. VI, 22; latest coin: Constantius II, c. 330-342 A. D.

10. Bronze enamelled disc with the remains of a rivet in the centre of the back. The outer circle is of dark blue enamel with light yellow rosettes, the second has a light bluish-green ground with dark-coloured fronds, while the centre consists of a chequer pattern of alternate dark and light spotted squares, in the millefiori manner. Site 1, 6. 3 ft. down.

A circular brooch found at Wroxeter in a deposit which was not later than the middle of the second century A. D. has very similar enamelling (*Wroxeter*, 1914, pl. XVI, no. 11).

Cf. *O. R. L. 8, Zugmantel*, pl. XXI, 13; and A. Bequet, *op. cit.*, pl. I, nos. 2, 4.

11. Flat bronze pendant with loop for attachment. The central decoration consists of four spirals arranged so as to form a swastika. Nothing exactly similar can be found recorded, but the central motive recalls some of the patterns on Saxon saucer-brooches of the fifth century, and it appears probable that this pendant belongs either to the late fourth or the fifth century A. D., the technique anticipating the chip-carving (*Keilschnitt*) which flourished in north-west Europe in the fifth century (cf. Vermand examples in Eck, *Cimitières Gallo-romains*, pl. XVII).

Site 1, 6. 3 ft. from surface.

12. Portion of a thin panel of bone with S VIVAS, obviously the end of an inscription, cut upon it. The edges of the panel are notched, and the letters are enclosed within roughly incised lines.

Inscriptions of a complimentary nature generally considered to be Christian (although there appears to be insufficient evidence for this), and as a rule consisting of VIVAS coupled with a personal name either in the vocative or nominative, are not uncommon, especially on metal objects, but no other example can be found recorded on bone except a somewhat similar example from Chesterton, Hunts (*V. C. H. Northants*, i, 170).

Roman spoons inscribed AETERNVS VIVAS and AVGVSTINE VIVAS have been met with (*Antiq. Journ.*, vol. ii, p. 89), and a ring in the British Museum bears the inscription MARTINIANVS VIVAS (*Brit. Mus. Cat. of Finger Rings, Early Christian, Medieval, and later*). In the present example the word preceding VIVAS ends in S, and is probably in the nominative case.

13. Bronze plate and two circular-headed studs. These studs were originally attached to the centre of each of the rectangular portions of the plate. Probably an ornament on leather, the plate on the underside holding the two studs in position. Site 1.

14. Bronze object, the central portion being flat while the terminals have been hammered out and bent over.

It is possible that this was a double paint-brush, the hairs being held by the bent-over portions. Site 1.

15. Bronze bell with loop for suspension. Found near the postern gate in the top soil, and probably late third or fourth century.

Cf. *O. R. L.* 8, *Zugmantel*, pl. XII, 48, 49; and no. 30 below.

16. Decorated bronze terret for reins. North-west of site 1.  
Cf. *Newstead*, pl. LXXV, 2, 12.

Several examples of these terret rings have been found in this country ornamented in Late Celtic style (*Brit. Mus. Early Iron Age Guide*, 2nd ed., fig. 189). The wavy line separating the two faces is a British characteristic, and is noticed in *Archaeologia*, lxiii, 16, figs. 14, 15.

17. Iron spear-head with barbs and socket. Found in the west gateway of the fort.

18. Iron knife with bone plates, decorated with a pattern in incised lines, and riveted on the handle. Site 1.

Cf. *Wroxeter*, 1913, pl. IX, fig. 1, no. 8.

*O. R. L.* 29, *Hofheim*, pl. VIII, 39; Eck, *Cimitières Gallo-romains*, pl. XII, no. 9.

19. Bronze object, probably a handle, which may have had a bone or wood casing now decayed. When found it appeared to have a thin iron extension, but this was in a very friable condition and disintegrated when touched. Site 1.

Cf. perhaps Jacobi, *Saalburg*, pl. XLV, nos. 12-19.

20. Long narrow strip of ornamented bone. Both ends are pierced, the holes containing the remains of iron rivets or links. It may have been an armlet, a binding for a box, or possibly a hair ornament. Site 1.

21. Bronze steelyard-weight in the form of an acorn. It consists of a thin bronze casting, the upper and lower portions having been made separately and afterwards joined. The lower portion is half-filled with lead to give it the necessary weight. Site 1, 6. Top soil.

Cf. *O.R.L.* 8, *Zugmantel*, pl. XIII, 32, 33; *O.R.L.* 33, *Stockstadt*, pl. IX, 66.

22. Bronze netting needle. Found near the south wall of the fort. An iron example was found at Wroxeter (*Wroxeter*, 1913, fig. 5, no. 9, p. 13), and another at the Saalburg (Jacobi, *Saalburg*, p. 454, fig. 71, no. 12).

23. Intaglio from a ring, red jasper engraved with a stork holding a lizard in its beak. Site 1.

24. Intaglio of carnelian, from a ring, engraved with a figure of Mercury. Site 1, top soil.

25. Silver penannular brooch with ribbed decoration, the terminals being bent over and flattened. The pin is of bronze. Found during clearing operations undertaken by the Office of Works. This may be regarded as the beginning of the type that gave rise to the large penannulars of Ireland and Scotland (*Archaeologia*, lxxv, 226). The transverse ribbing is characteristic, and the returned ends suggest an origin for the animal-headed terminals of the later series (see *Proc. Soc. Ant. Scot.*, 1, 101).

26. Bronze penannular brooch with rolled-over terminals forming small loops. Site 1, surface.

Common articles on Roman sites (see *Newstead*, pl. LXXXVIII; *Wroxeter*, 1914, pl. XVI, 14).

27. Bronze mount or escutcheon, pierced in the centre for a rivet, which may have had a loop or handle on the head. East of site 1.

Cf. *Newstead*, pl. XCII, 2.

28. Bronze clasp or button with long bar of circular section and loop for sewing to cloth or leather. Site 1.

These articles in various designs are common on Roman sites, and were probably used for fastening coats of chain-mail, clothing, etc.

Cf. *Newstead*, pl. LXXV, figs. 7, 8; *Wroxeter*, 1912, pl. x, fig. 1, no. 4; 1913, fig. 5, nos. 15, 16; 1914, pl. xvi, no. 15.

29. Bronze martingale with three loops by which the straps were united. Decorated with a man's head in high relief, the hair being parted in the centre and cut in a straight fringe on the forehead. Site 1.

Cf. phalerae in *Newstead*, p. 299, fig. 43, and pl. LXXIV, 6.

30. Small bronze bell with loop for suspension which has been almost worn through by wear.

Site 1, room 4.

Cf. *O. R. L.* 8, *Zugmantel*, pl. XII, 47. This form is represented at Hofheim (*Hofheim*, xl, pl. XIV), and also in London (*Brit. Mus. Guide to Roman Britain*, fig. 48, right). See 15 above.

31. Bone die with the numbers one to six. Site 1. These are frequently found on Roman sites (*Wroxeter*, 1913, pl. IX, fig. 1, 6; *Newstead*, pl. XCIII, 3).

32. Bronze crescent-shaped pendant with loop for attachment. Site 1. The origin of this type of pendant is obscure, and worship of the moon (Luna) is not excluded: parallels are known from Britain (usually with the loop on the convex edge) and an explanation is offered in *Proc. Soc. Ant.* xxx, 61.

33. Bronze finger-ring decorated with transverse grooved lines. Site 1.

Another, with lobes rather than ribs, was found at Traprain Law (*Proc. Soc. Ant. Scot.*, 1, 100, fig. 23, no. 12).

34. Decorated strips of bone pierced for attachment with rivets: probably used for binding caskets or boxes. Site 1.

35. Iron pioneer's axe, with socket for haft: a 6-in. cutting-edge at one end and a 2-in. pick at the other, total length 15 in. Well 2, first century.

See *Wroxeter*, 1914, p. 31, 3.

36. Iron socketed spear-head. Site 1, room 7.

Cf. *O. R. L.* 71 a, *Theilenhofen*, pl. IV, 46; *O. R. L.* 8, *Zugmantel*, pl. XIV, 8; *O. R. L.* 23, *Gross-Krotzenburg*, pl. V, 10; *O. R. L.* 3, *Arzbach*, pl. III, 1.

37. Iron socketed spear-head. Site 1, 9.

Cf. *O. R. L.* 73, *Pfünz*, pl. xv, 6; *O. R. L.* 29, *Hofheim*, pl. VIII, 25.

38. Socketed iron lance-head. Found near the outside face of south wall of fort.

Cf. *O. R. L.* 2 a, *Niederberg*, pl. VII, 18; *O. R. L.* 33, *Stockstadt*, pl. IX, 8.

39. Large bronze nail. North-west of site 1. Although this probably had an ordinary use, it may perhaps have been a votive object, the nail in primitive times being a form of currency; examples are sometimes ornamented (*Brit. Mus. Guide to Roman Britain*, fig. 41), and may have been used for magical purposes (*Defixio*, see *Brit. Mus. Guide to Greek and Roman Life*, 2nd ed., p. 56: see also Cumont, *La Belgique romanisée, Annales de la Société royale d'Archéologie de Bruxelles*, xxviii (1914-19), p. 174).

#### *Lamps* (plate XIX)

4. Lamp with triangular nozzle flanked by volutes. Moulded rim and no handle. Light yellowish clay with reddish brown wash. The top decorated with lion bounding left. Site 1, room 3. Walters, *Lamps*, pl. XLII, 78, and pl. XVII, 545, 547, 564, and pl. XXI, 571. First century A. D.

Hofheim, type 35. Flavian.

5. Lamp with rounded nozzle flanked by volutes. A small hole between the volutes. The top decorated with eight petals within a grooved circle. No handle. Dirty white clay with yellowish brown wash. Well 1, near bottom, mid or second half of first century. Walters, *Lamps*, pl. XXIV, 727, and p. 101, fig. 121, first century.

Hofheim, type 36. Flavian.

6. Lamp with oval body, broad shallow groove leading to nozzle. Handle and nozzle broken. Dirty drab clay. Decoration consists of what appears to be a floral motive within a conventional wreath. Raised dots in field. Two oil-holes. Found in connexion with Marne ware and other pottery of the late fourth century.

Walters, *Lamps*, p. 203, fig. 306 (late or quasi-Christian type).

#### *Glass* (plate XIX)

7. Cup of thin pale blue glass with pronounced conical kick in base, which is not centrally placed. Two incised lines on bulge and another near rim. Immediately below the rim a slightly

grooved band. The lip rough. Well 1 bottom, mid first century. Similar cups occur in the Claudian period at Hofheim (*Hofheim*, pl. xxxviii, type I A).

8. Cup or beaker of very thin white glass. Four large oval indentations in the sides, an incised line immediately below the smooth lip, a foot-ring and domed base. Well 1 in association with the last and therefore of the same date.

## POTTERY

### THE DECORATED SAMIAN

(Plates xvii-xix)

Roughly a thousand fragments of decorated bowls were discovered during the two seasons' work. Of these some hundred and eighty were form 29, and although the majority of them were of Flavian date a few pieces were earlier, some undoubtedly belonging to the time of Claudius (nos. 1-4). About three-quarters of the fragments found could be assigned to a date before the reign of Hadrian, upwards of five hundred being of form 37 decorated in the style that was in vogue towards the end of the first century and in the early years of the second (nos. 14-18). There were about two hundred and fifty fragments of bowls, form 37, of definite second-century type of which the greater part could be assigned to the Antonine period, while a few were of poor technique with very indifferent decoration obviously of late second-century or even third-century date. Only forty-two pieces of form 30 were met with, and of these twenty-five were first-century examples. Forms 67 and 78, types belonging to the last quarter of the first century, were each represented by five fragments. Practically all the first-century and very early second-century examples were from La Graufesenque or one of the other south Gaulish potteries, and those of the second century were mainly made at Lezoux. The east Gaulish and German potteries were only represented by a few fragments.

It will be noted that the decorated Samian of the late first century and the early years of the second is by far the most plentiful on the site, but whether this indicates a more intensive occupation or a larger importation of this ware into Britain at that period is a point that cannot be easily decided. Sites occupied continuously in the first and second centuries in this country as a rule yield a large proportion of Samian of this



period, and it is not impossible that as Britain became more settled in the second century local productions competed to some extent successfully with this fine imported pottery. So much of this ware has, however, been found at Richborough belonging to the Domitian-Trajan period that there can be little doubt that the portion of the site excavated was at that time the scene of considerable activity. This may have been due in some degree to the military operations carried out in the north and west at this period, as many of the troops and much of the supplies coming from the Continent probably passed through the port of Rutupiae. It should not, however, be forgotten that, if the suggestion already made that this part of the site was intensively occupied by artisans employed on the great marble-cased building in the late first and early second century should be correct, this in itself would be sufficient reason for the large amount of pottery of that period met with.

1. Form 29. Upper frieze divided into metopes by corded lines in which are alternate medallions and festoons. Small rosettes of eight petals in the field. The medallions contain swans and the festoons leaves on stalks formed of wavy lines. A plain moulding between two beaded lines below. The lower frieze is in two bands, the upper consisting of a wreath of leaves and the lower of a running scroll with tendrils ending in buds and rosettes of fifteen petals. Good bright red glaze. Pit 14. Claudian. Style of the potter Licinus and probably from La Graufesenque.

Cf. bird, *Hofheim*, pl. xxv, 1 ; buds, Oswald and Pryce, pl. xxxi, 21, from Vindonissa ; lower frieze, *Hofheim*, pl. xxiii, 2.

2. Fragment of form 29. Upper frieze consists of a running scroll with tendrils ending in dart-shaped buds with conventional leaves, and in fan-shaped leaves. Two small spiral tendrils spring from the binding. A beaded line above and below. The existing portion of the lower frieze shows part of a band of godroons with a beaded line above. A plain moulding separates the two friezes. Pit 14. Claudian. Probably La Graufesenque.

Cf. Oswald and Pryce, pl. xxxi, 41, from Xanten ; Walters, *B. M. Cat.*, fig. 32, M. 4 ; *Hofheim*, pl. xxv, 4, and pl. xxiii, 1.

3. Fragment of form 29. Upper frieze consists of corded festoons and tassels containing crossed tendrils ending in leaves. Lower frieze a running foliage-scroll with large leaves and acorns. Between the two friezes a plain moulding and two beaded lines. In lowest road-metal section 1 (pl. xxxiv). Probably Claudian from La Graufesenque.

Cf. acorns, Oswald and Pryce, pl. xxv, 3, Tiberian from Strasburg; *ibid.* 5, from Hofheim. Festoons containing crossed tendrils, May, *Silchester*, pl. xii, 32.

4. Fragment of rim form 30. Well-formed ovolos with single borders and no tassels beneath a fine beaded line, and a slightly curved row of delicate rosettes with twelve petals below. Good red glaze with fine finish. Casual find in field south of fort. Shows strong Italian influence and probably Claudian.

5. Rim fragment of a small cup with side sloping slightly inwards towards the base. Possibly Hofheim, type 20, or may be an early variety of form 78. Well-formed ovolos with double borders and beaded tassels ending in small rosettes beneath a beaded line. A row of delicate rosettes below. Thin fabric with bright red glaze. Found at a low level by the turret on the south wall of the fort. At about the same level and near at hand was a coin of Claudius I. Probably pre-Flavian.

6 and 6 A. Fragments of form 29. The upper and lower friezes are separated by a plain moulding between two beaded lines. Lower frieze in two bands, the upper consisting of a wreath of five-pointed leaves and the lower of a running scroll with tendrils ending in leaves. Good red glaze. Probably La Graufesenque 65-80 A.D. Site 1, room 2, below 4 ft.

Cf. wreath, *J. R. S.*, vol. iv, part I, pl. v, 21, from Pompeii; leaf, Knorr, *Südgallische Rotrweil*, 1912, pl. viii, 2, 3, and *Rotrweil*, iv, 1 (Germanus); binding, Oswald and Pryce, pl. xxxii, 36, Vespasianic.

7. Fragment of upper frieze of form 29. Running scroll decoration consisting of tendrils ending in seven-pointed leaves and a small spiral. Between the leaves a small circle with raised centre. A beaded line above and below. Poor yellowish glaze. West Gate, low level. Uncertain provenance and date, but may be Lezoux, early Flavian. Another portion of this bowl was found in pit 8, 20-26 ft. down, in a deposit of first-century date. This portion showed that the lower lobes of the scroll on the upper frieze contained similar leaves to those on the fragment illustrated. A small portion of the lower frieze had on it part of a running scroll or wreath composed of leaves with two petals (compare *Hofheim*, pl. xxvi, no. 3).

8. Fragment of upper frieze of form 29. Running scroll with a rosette binding and tendrils ending in dart-shaped buds with conventional leaves and in small rosettes of ten petals. A beaded line above and below. Dull red glaze. Site 1, room 3, low level. Second half of first century.

It is in the style of the potters Bassus and Coelius of La Graufesenque, and probably of early Flavian date. *Hofheim*, p. 237.

Cf. Walters, *B. M. Cat.*, M. 4 ; May, *Silchester*, xi, 6.

9. Fragment of lower frieze of form 29. The scroll decoration is not continuous but appears to have been composed of separate bunches of tendrils ending in leaves and buds. Above is a beaded line. Good red glaze. Site 1, room 2 B, bottom layer, 60-85 A.D.

For buds and leaves compare : Oswald and Pryce, pl. xxxvii, 76 ; *J. R. S.*, vol. iv, part I, figs. 21, 52 ; Curle, *Newstead*, p. 213, no. 3 ; Knorr, *Rottweil*, i, 14. Probably La Graufesenque, early Flavian period.

10. Fragment of upper frieze of form 29. Festoon of three lines containing a tendril with dart-shaped bud and conventional leaves. A beaded line above and below. Dull red glaze. Site 1. Probably La Graufesenque, late Flavian period. See no. 12. Cf. *J. R. S.* iv, pl. xi, fig. 57.

11. Fragment of upper frieze of form 29. Metope decoration. A dog running right with tendrils above and to the right, two tufts of grass below. A beaded line above and below. Dull red glaze. Site 1, room 2. The dog is not given in Déchelette, but is similar to that on the bowl form 37 with the stamp M CRESŦIO, pl. xix, no. 2, of this report. South Gaulish of the late Flavian period.

12. Fragment of lower frieze of form 29. The decoration consists of festoons of three lines divided by tassels with fan-shaped terminals. The festoon contains a tendril ending in a dart-shaped bud with conventional leaves. Poor red glaze. Site 1. South Gaulish of the late Flavian period. See no. 10.

Cf. *J. R. S.*, vol. iv, part I, pl. xi, fig. 57 ; pl. xiii, 63, 71 ; Curle, *Newstead*, p. 205, 3.

13. Fragment of form 30. Well moulded ovolos with double borders and tassels ending in large rosettes, a wavy line below. Decoration in arcades separated by a poppy head and a vertical row of small circles. The arches of arcades formed of two lines and containing crouching hares facing right and left with a wavy line below. The lower part of arcade is bordered by vertical beaded lines and contains a figure facing right, holding a staff in left hand and with right hand on hip. Good dark red glaze. Site 1, room 6. Probably south Gaulish, about 75-100 A.D. For ovolo and small animals within semicircles cf. *J. R. S.*, vol. iv, part I, pl. vii, 42.

14. Fragment of form 37. Decoration in transitional style. Lower frieze, a dog running to right between fan-shaped ornaments. Above are festoons and tassels, the festoons containing spiral tendrils ending in rosettes, and above these again are the feet of an animal running left and part of a fan-shaped ornament. Above the frieze and on either side of the other motives is a cruciform ornament composed of wavy lines with rosettes at the angles, and leaves, probably on tendrils, branching from the centre. Dark red glaze. South Gaulish of the late first or very early second century.

Cf. *Arch.* lxiv, pl. xxiii, 19, Nether Denton; pl. xxii, 13, Carlisle; pl. xxiv, 38, 39, South Shields; Curle, *Newstead*, p. 215, fig. 1; p. 209, fig. 2; *J. R. S.*, vol. iv, part I, pl. III, fig. 11; Knorr, *Südgallische Rottweil*, pl. xx, 1.

15. Fragment of form 37. Decoration in transitional style, consisting of a festoon of three lines containing a tendril ending in a dart-shaped bud with conventional leaves enclosed in a small metope of beaded and wavy lines with rosettes at the angles. Imbricated arrow-heads above. To the right, part of a metope with tendrils ending in leaves at the angles and a small portion of the outer ring of a medallion. Below a continuous band of S-shaped ornament. Another fragment of this bowl, not illustrated, shows another metope containing Jupiter standing left (Déch. 2) with a small altar on the left and an eagle on the right in a medallion of three concentric circles. Tendrils ending in leaves spring from rosettes at the angles. Bright red glaze. Site 1, room 2, below 4 ft. South Gaulish of the late first or very early second century.

Cf. Knorr, *Südgallische Rottweil*, pl. xx, 1-4; Curle, *Newstead*, p. 205, fig. 8; *Arch.* lxiv, pl. xxii, 12, Carlisle.

16. Fragment of form 37. Running scroll pattern with tendrils ending in leaves and poorly moulded rosettes. A rosette in the field. Below, a beaded line and a conventional chevron leaf wreath. Good red glaze. Site 1. South Gaulish, 75-95 A.D.

Cf. wreath, *J. R. S.*, vol. iv, pl. viii, 46; pl. xi, 57; pl. xiii, 71; scroll, *J. R. S.*, vol. iv, pl. vii, 37, 38; pl. viii, 46.

17. Fragment of form 37. Decoration in transitional style, the main motive being a running scroll with the lower lobes containing animals above conventional grass. Above the scroll is a narrow wreath of conventional leaves and below a band of the S-shaped ornament. Bright red glaze of fair quality. Site 1, room 5. South Gaulish of the late first century. Hare, Déch. 951, and *J. R. S.*, vol. iv, pl. x, 51, on which the dog and a running scroll also occur.

Cf. Curle, *Newstead*, p. 215, no. 8; Knorr, *Rottweil*, pl. xv, 12.

18. Fragment of form 37. Decoration in transitional style. Ovolos with double borders and tassels ending in three points. Between two wavy lines a frieze of festoons and tassels, the festoons composed of two lines and containing spiral tendrils ending in a ball, the tassels are formed of a wavy line ending in bunches of three conventional leaves. A band of rosettes below. Lightish red glaze of inferior quality. Site 1. Provenance uncertain. Late first or early second century.

19. (Pl. XIX, no. 1) Form 37. Ovolo of three rings with plain tassel ending in a ball resting on a line below. The decoration, which is separated from the ovolo border by a wavy line, is of a mixed and unusual character. It consists of a bird surrounded by five bunches of grapes with two or three leaves below and rosettes in the field. This group alternates with panels of various sizes formed of wavy lines with diagonal wavy lines running from the angles and crossing in the centre, rosettes being placed at the angles. The triangular spaces are filled with conventional three-leaf ornaments. Above the larger of these panels is a row of three leaves, the smaller having in addition a horizontal row of rosettes. Below this decoration and separated from it by a girth-groove is a band of irregularly spaced slight excrescences, probably blurred rosettes.

Practically all these motives may be seen on a fragment of a bowl, form 37, from Zugmantel which is assigned to the potter Toccus, whose stamps have been found in the ditch of the early fort at Saalburg and at Gross-Krotzenburg, both of the Hadrianic period. See *O. R. L., Zugmantel*, pp. 115-16 and pl. XXII, 10, where other fragments with some of these motives may also be seen. A stamp of Toccus was found at the potteries of Lavoye in East Gaul. Fölzer, p. 37.

## POTTERS' STAMPS

1. On Samian			
D. Decorated	.	.	12
P. Plain	.	.	94
			106
Uncertain or illegible	.	.	37
2. On Belgic ware	.	.	1
3. On a lamp	.	.	1
4. On amphorae	.	.	10
5. On mortaria	.	.	7

Of the Samian stamps that are certain, 70, viz. nearly two-thirds, can be traced to South Gaulish potteries and are therefore

of first or early second century date. Of these 70, eight are definitely pre-Flavian (in addition to two probable ones among the uncertain class), and twenty more can be classed among those potters who began working in pre-Flavian times. Only fourteen stamps are of Antonine date, only one comes from Rhenish potteries, and none can be placed in the third century.

Four of the ten amphora stamps also fall within the first century, and as many more of the mortarium stamps, if one may judge by their shapes.

## POTTERS' STAMPS ON SAMIAN

## Provenance.

## South Gaul :

La Graufesenque . . . . .	54
"    probable . . . . .	2
Montans . . . . .	2
"    probable . . . . .	2
Banassac probable . . . . .	1
Pottery uncertain . . . . .	9
	<hr/>
	70

## Central Gaul :

Lezoux . . . . .	12
"    probable . . . . .	5
	<hr/>
	17
Lezoux or Blickweiler . . . . .	2

## East Gaul :

Heiligenberg . . . . .	1
Lavoie probable . . . . .	1
Pottery uncertain . . . . .	2
	<hr/>
	4
East Gaul or Gallia Belgica . . . . .	1
Gallia Belgica ? . . . . .	1
Gaulish . . . . .	5
Rheinzabern . . . . .	1
Unassigned . . . . .	5
	<hr/>
	5

Total 106

## STAMPS ON DECORATED SAMIAN, D

- I. (A) MCRESTO. 37. Raised letters horizontally in decoration. Site 1, room 6. In a deposit mostly of first-century date.

Decoration : large scroll. Upper lobes contain leaves and birds r. (cf. Déch. 1034). Lower lobe divided into two panels by

beaded line with rosettes at angles. Upper panel contains fan-shaped plant between two spirals, as in Knorr, *Rottw.* xi, 1. Lower panel: below stamp, dog running r., in *Arch.* lxiv, pl. xxiii, 17 (Nether Denton), dated 90-120 A.D. In another lower panel: rabbit r., as in Knorr, *Rottw.* xi, 1. Below: corded line above a decorative band (pl. xix, no. 1).

La Graufesenque potter (Déch. 1, 268), who uses shapes 29, 37, and 27.

Dating: Foreign: *Südgall. Rottw.*, pp. 45-6. Wiesbaden, *O. R. L.* xxxi, p. 109, 36-7, on a very early Drag., 37. British: *Wroxeter*, 1914, p. 55 (incomplete stamp). Late first and early second century.

*C. I. L.* xiii, 10011, 187; Walters, M. 554; Oswald and Pryce, pp. 58, 80, 94, 112.

2. (A)  $\text{DID}$ . 37. Monogram of Doeccus, immediately below ovolo and horizontal line of long beads. Site 1.

A Doeccus worked at Blickweiler (Bavarian Palatinate) c. 100-140 A.D., and at Lezoux c. 140-180 (D. Atkinson, *Lowbury Hill*, pp. 56-9). The above monogram occurs at Blickweiler, attached, as here, to vertical staves. In Germany the same potter is frequently found in the Hadrianic period (117-138 A.D.) on the Limes, e.g. in the ditch of the earth fort at the Saalburg (*O. R. L.*, *Zugmantel*, p. 114). In Britain a band of the double-D monograms in the place of the usual ovolo was found at Wroxeter (1912, p. 44) and dated not later than 120 A.D. For the Lezoux potter see Déchelette, i, 270-1 (decorated), and *C. I. L.* xiii, 10010, 814; xii, 5686, 322-3 (plain). Mr. Atkinson (*op. cit.*) gives a list of most of the sites in Britain where the decorated bowls have been found.

Oswald and Pryce, pp. 62, 94, 112.

3. (A)  $\text{GIIIMINVS}$  (retro). 37. Graffito on mould below decoration. Site 1.

Three pieces. Ovolo with slight slant and tassel attached to l. side. Decoration in panels and subdivided panels with rosettes of nine petals. Legs of nude figure, very possibly Déch. 399 (Libertus). In field: billets, smaller than Déch. 1111. Cf.  $\text{GIIIMIINI}$ , graffito below decoration, on a 37 mould from Lezoux, probably of the same potter (Déch. 1, 273).

A Hadrian-Antonine potter of decorated and plain ware, probably of Lezoux. Site dating: *O. R. L.*, Cannstatt (Barthel), first half of second century. In Britain: Newstead (*Report*,

p. 236), second century with Trajan coin. Corbridge (1911, p. 39), with Antonine pottery and two dupondii of Marcus, dated 155 A. D., in good condition. Wroxeter (1913, p. 41, nos. 55 (A) and (B)), in two pits, one mostly Antonine and the other probably Hadrianic or Antonine. *C. I. L.* xiii, 10010, 955; vii, 1336, 477; Walters, M. 1620, 1710-12, 2241 (on Drag. 45). May, *Silchester* (p. 223) and Guildhall Museum (R. xi, 553) also record stamps on Drag. 45.

4. (A) NIS. 29. = OF LABIONIS.

East of west gate in a low-level rubbish layer.

Labio or Labeo, a La Graufesenque potter, is probably only pre-Flavian (Ritterling, *Hofheim*, p. 249), for his stamps have been found at Wiesbaden (4) and at Hofheim (3), both in their earlier periods, and at the Sels tilerly (6) and in the legionary camp at Neuss (6). In Britain they have been recorded in London (Walters, M. 306, 811, 918; *Arch.* lxvi, 268), 6 stamps, at Chester (2), Silchester (1), and Templeborough (1). The forms used are Drag. 15, 18, 18/31, 27, 29, 31, and Ritterling 8 (early Drag. 40).

*C. I. L.* xiii, 10010, 1101-3 (Labeo), 1104 (Labio), ii, 4970, 183 and 257, 6257, 103 (Spain), iii, 6010, 114 (Bregenz); Oswald and Pryce, pp. 50, 82.

5. (A) MERCATO (retro). 37. Sunk lettering on a raised label in decoration. North-west of site 1.

Details of bowl: small dog running l., not in Déchelette; palm-tree (top); below, a band of S-shaped ornaments.

This potter is to be distinguished from others of later date who always stamp MERCATOR, and probably worked at La Graufesenque, to judge by the details and transitional style of his Drag. 37 bowls, and not before 80 A. D. (Ritterling, *Hofheim*, p. 250). Mr. D. Atkinson places him amongst the latest South Gaulish potters, including Biracil, L. Cosius, and Crucuro, who belong to the Domitian-Trajanic period (*J. R. S.*, 1914, iv, pt. I, pp. 31-33). May, *Silchester*, xxv, 5-7, shows three similar stamps with palm-tree and S-shaped ornaments. MERC or MERCATO has also been noted in Britain, in London ((1) British Museum, (4) Guildhall), and at Chester (2), Corbridge (1), York (1), and Godmanchester (-ATO on Drag. 18). The Dragendorff forms used are 18, 18/31, 27, 31, 33, 29, 37.

*C. I. L.* xiii, 10010, 1343-4; 10011, 236; ii, 6257, 119; 6349, 28; xii, 5686, 582-3; Walters, M. 2305; Déch. i, 286-7; Oswald and Pryce, pp. 58, 83, 119.



6. (A) M O  $\frac{1}{2}$  A. 29. Faint lettering, below decoration. Site 1, room 7, low level.

Mommo, whose name is attached to the largest number of vessels (9,000) mentioned in graffiti found at La Graufesenque (Déch. i. 86 f., 287 f.), had about fifty years of activity, c. 30–80 A. D., and has been found on many British sites, which his wares would have probably reached, in most cases, towards the end of that period. His decorated wares are datable to 77–79 A. D. by the Pompeian hoard, described by Mr. D. Atkinson in *J. R. S.* iv, i (1914), pp. 31, 32, 39. He is here grouped with Crestus, Germanus, Manduillus, Meddilus, Patricius, Rufinus, Sabinus, and Vitalis.

He uses Ritterling forms 1, 8, and 9, and Drag. 15, 18, 18/31, 24/25, 27, 29, 30, 33, 37.

*C. I. L.* xiii, 10010, 1374; ii, 4970, 330; xii, 5686, 600, 602; xv, 5355; Déch. i. 287–8; Walters, M. 28, 680, 828–30, 952–3, 992; Oswald and Pryce, pp. 53, 83.

7. (A) (1)  $\widehat{\text{P}}\widehat{\text{A}}\widehat{\text{T}}\widehat{\text{E}}\widehat{\text{R}}\widehat{\text{N}}\widehat{\text{F}}\widehat{\text{E}}$  (retro) 37. North-west of Site 1 in a deposit of the Antonine period.

- (2)  $\text{N}\widehat{\text{F}}\widehat{\text{E}}$  (retro) 37. East of Site 1.

Both the complete stamp and the fragment are raised lettering, as given in Déch. i, p. 289, 140, 1, and are placed in the decoration.

No. (1) is on a bowl in Free Style of which large portions are preserved. Details: Horseman galloping r., Déch. 157; bear (?) bounding r., cf. Déch. 810; quadruped r., Déch. 968; roebuck r., Déch. 860; lioness bounding r., Déch. 789; small dog running l.; conventional tufts of grass—'spike blossom' shaped. All five Déch. types are already identified with Paternus. The first four also occur on his signed bowl in the British Museum (Walters, M. 1463, plate xxxi), which is very similar.

No. (2) shows a medallion within a panel of vertical cabled lines with a plain line below. Within the medallion: Pan mask l., Déch. 675. Outside on l.: the stamp vertically downwards. In lower r. spandrel of next panel l.: an annulet, as in Déch. 1098.

A Paternus or potters of this name worked at Lezoux, Rhein-zabern, and in East Gaul. The above stamps belong to the Lezoux pottery and are assigned by Déchelette (i, p. 190) to the Antonines and by Oswald and Pryce (pp. 63, 120) to the Hadrian-Antonine period. At Wroxeter (1914, p. 53, 86 (c)) his stamp on Drag. 27 was dated before the middle of the second century. Last summer, too, on the same site a hoard of twenty-

eight Sigillata vessels was found, including two decorated bowls with the same stamp of Paternus. The group is dated by Mr. D. Atkinson about 160 A. D. (*Birmingham Post*, July 15, 1924, p. 7).

Déch. i, 289-294; *C. I. L.* xiii, 10010, 1508; xii, 5686, 677; Oswald and Pryce, pp. 63, 95, 120.

8. (A) **SECUNDINIM** (retro) 37. Small sunk lettering upside down on a raised band in the decoration. Sharp mould, dull glaze. Site 1, room 6. In a deposit assigned to 80-120 with stamps 4 (A), 46 (A), 65 (F) on plain Samian.

Decoration: small medallions of double concentric circles separated by a trophy of which the cuirass at the bottom alone survives. Déch. 1117, Lezoux. Under l. medallion, the stamp. Under r. medallion, hind, couchant l., head turned r. Déch. 879, Lezoux, used by Bassus, Eppillus, Laxtucissa, Libertus, Sacer and Doecus. Secundinus made decorated and plain pottery at Lezoux.

Site dating:

Cannstatt, *O. R. L.* lix, 155. First half of second century.

Saalburg, ditch of the earth fort. Before 139 A. D.

Newstead, Curle, pp. 240-1. First half of second century.


Déch. i. 298-9. *C. I. L.* xiii, 10010, 1763, and 10011, 120, 133, 264, 266; ii, 4970, 462; vii, 1336, 1004, 1006, 10012; xii, 5686, 799; Oswald and Pryce, p. 123.

9. (A) **VITALIS** 29. Stamped within double concentric circle inside base. North-west of Site 1 near north wall of fort.

The well-known maker of decorated and plain wares of La Graufesenque, one of several potters of this name working at different potteries and dates. Ritterling (*Hofheim*, 246, 249) states that he began producing under Nero, but that his chief activity was under the Flavians. His wares have been frequently dated, both in Britain and abroad, at the end of the first century, e. g. at Wroxeter (1912, p. 63), 75-85 A. D.; (1913, p. 43) 80-110 and 80-120 (twice); (1914, p. 54) late first or early second century; at Newstead (p. 242) 80-110; at the General Post Office (*Arch.* lxvi, p. 260) in two pits both of the late first century, and at Hofheim in the Flavian camp. See also under decorated stamps, no. 6 (A), Mommo. He uses Dragendorff forms 15, 17, 18, 18/31, 24/25, 27, 29, 31, 33, 36, and 40. There are many stamps in the British Museum Catalogue.


Déch. i, 303; *C. I. L.* xiii, 10010, 2062; ii, 4970, 559 and 6257, 212-14; iii, 6010, 235; vii, 1336, 1200, 1204; xv, 5765; Oswald and Pryce, pp. 55, 86.

## UNCERTAIN OR FRAGMENTARY STAMPS

10. (A)  F. 37. Large raised lettering, stamped perpendicularly upwards in decoration. Site 1, room 8.

Details. Ovolo with beaded line below as in Curle, *Newstead*, p. 227, 4 (Antonine). Upper part of figure of Mars, full face, seated, r. arm holding lance, Déch. 94. Over his l. shoulder, pigeon l., head r., Déch. 1018, Libertus.

The stamp, if complete, would probably be either AVSTRIOF or MAPILLOF (the latter being less common), as both use the O with central dot. Both Austrus and Mapillius were Lezoux potters (Déch., i, pp. 252-3, 285), who worked, probably early, in the Antonine period. Cf. Oswald and Pryce, pp. 107, 118.

11. (A)  SACRI. 37. Small. = ? OFI SACRI. Stamped in mould upside down below decoration. Pit 8, top. Late first and second century.

Decoration: parts of four narrow panels divided by lines of flattened beads terminating in rosettes. Cf. a signed bowl of Sacer, Knorr, *Cannstatt*, v, 5.

Ovolo: festoons of double loops, separated by tassels ending in open lozenges.

Panels from l. to r. Panels 1 and 3: cruciform pattern composed of two bunches, each of an open lozenge between two conventional leaves smaller than Déch. 1153 (OFI SACRI, Lezoux), separated by a small bird (shrike) l., cf. Déch. 1046 (rev.), Lezoux. In field, two stars. Panel 2: gladiator l., cf. Déch. 617 (rev.) Lezoux. In field, three stars. Panel 4: small medallion of two concentric circles (pl. xix, no. 3).

This bowl is of Lezoux origin, and belongs to the first half of the second century. A Sacer bowl at Silchester (May, pl. xxii, p. 255) has been assigned by Mr. Bushe-Fox to the Trajan-Hadrianic period (*Wroxeter*, 1912, p. 46).

Sacer is also placed in first half of second century in Knorr, *Cannstatt*, p. 18, and *O. R. L.* xxviii, *Cannstatt*, 64.

Cf. Oswald and Pryce, p. 122.

## STAMPS ON PLAIN SAMIAN, P

1. (A) ADVOCISIO. 33. Small. Site 1, room 6, top soil.

Maker of decorated and plain wares at Lezoux, where he worked in the Antonine period. This is shown by his use of Drag. forms 38/44 (May, *Carlisle*, p. 63), 51 or Lud. Tx. (May,

*Silchester*, p. 200), 79 (Guildhall Museum and Godmanchester), and 80 (Walters, M. 1748 and May, *op. cit.*).

Site-dating: Newstead, second period (Curle, pp. 228, 231).

Wroxeter hoard 1924, *c.* 160 A.D.

Déch. i, 247-8, *C. I. L.* xiii, 10010, 43; vii, 1336, 16; xii, 5686; Oswald and Pryce, pp. 61, 94, 105.

2. (A)  $\uparrow$ LBVSF. 18/31. Thin, dull glaze. Site 1.

Maker of decorated and plain wares at La Graufesenque, who first appears in pre-Flavian sites, e. g. Wiesbaden (*Nass. Ann.* xxix, p. 145). Other site-dating: Neuss, first century (*C. I. L.* xiii, 10010, 86, gg<sup>1</sup>), Stockstadt, end of the first century (*O. R. L.* xxxiii, Stockstadt, p. 100), Wroxeter, 80-110 A.D. (1913, no. 135 B) and Segontium, with late first and early second century pottery (pit 1 outside the walls, 1920). In Britain, besides those places named in *C. I. L.* vii, 1336, 48-50, stamps of Albus have been noted at Aldborough, Caister by Norwich (1), Chester (4), Silchester (3, May, *Silchester*, p. 202) and in London (4, Guildhall Museum). They are found on Drag. 15, 18, 24/25, 27, 29, 31, 33.

Déch. i, 250: *C. I. L.* xiii, 10010, 78, 86; ii, 4970, 19; xii, 5686, 28, 34; Oswald and Pryce, p. 78.

3. (A)  $\uparrow$ NEXI·Z. 33. Coarse ware, indifferent glaze. Site 1, 9.

Probably a new variant of the name of the rare potter who stamps Anextlati or Anexia (always with NE ligatured). Site-dating for Anextlati: Windisch, first century, also recorded at Poitiers (2), Besançon, Vienne, and Rheinzabern (on Lud. Sa?). Anexia is noted at Nêris, Bonn, Vechten, Mainz, and Eppelsheim (Hesse). The last one, in the British Museum (M. 97), is on Drag. 17 (nearly), a pre-Flavian form. Its early date seems to be corroborated by the Silchester stamp  $\uparrow$ NEXI on the base of a bowl, fine brown red, like Arretine (May, *Silchester*, p. 202).

*C. I. L.* xiii, 10010, 123, 124; xii, 5686, 632: Geissner, *Post-Augustan Sigillata in Mainz M.*, 1904, 2, no. 64; Ludowici, ii, p. 8.

4. (A) OFA·PRO. 33. Large, with a deep groove on the exterior angle. The upper side is slightly polygonal. Stamped within a circle on a coned base. Site 1, room 6, in a deposit assigned to 80-120.

The only dating for Apronius is *c.* 90-105 A.D., obtained at Corbridge (1912 *Report*, p. 43). If identical with L. Apron, he is a Montans potter (Déch. i, 151), who stamped on Drag. 29. Otherwise, his only form noted is Drag. 27, viz. at Corbridge (2), Chester (3), Leicester and London (British Museum).

The *C. I. L.* stamps APRON, APRONI, APRONIV, and APRONIOS probably belong to another potter still earlier in the first century.

*C. I. L.* xiii, 10010, 150-1, 153-4; ii, 4970, 39; iii, 1610, 17; *Arch. Ael.*, 3 S., ix, p. 271; Walters, M. 780.

5. (A) ARDA. 27. Large, good glaze. Site 1, 9.  
 " 27 " " " Site 1, 9, low level.  
 " 27 " " stamped within a circle. Outside west wall of fort.

Ardacus was a La Graufesenque potter, probably only pre-Flavian (Ritterling, *Hofheim*, p. 249).

Site-dating: Andernach, early cemetery, till 68 A. D.

Hofheim, 5, 40-51 A. D.

Neuss, 2, legionary camp, till c. 70 A. D.

Sels tilery, 5, till c. 40 A. D.

Wiesbaden, several, 37-69 A. D.

In Britain his stamps have been found at Cambridge, Colchester, Cirencester, Silchester (2), Wroxeter and London (British Museum, Walters, M. 783; Guildhall Museum, 3; London Museum, 2; and Society of Antiquaries, 1).

He uses Drag. forms 18, 24/25, 27, 29, 37, Ritterling 9 and quarter round fillet plate.

Déch. i, 251; *C. I. L.* xiii, 10010, 167; ii, 4970, 43 (Spain); viii, 22645, 32 (Cherchel, N. Africa); xii, 5686, 71-3 (Provence); xv, 5861 (Rome); Oswald and Pryce, pp. 50, 78.

6. (A) /ANVILLIM. 31. Dull glaze. = BANVILLIM. Site 1, room 6, top soil.

Banuillus, a comparatively scarce potter, has only this one form of stamp. His provenance is unknown. His vessels are usually of a patchy, pinkish-red glaze. Site-dating: Wroxeter (1912, p. 48, 18 on Drag. 27), probably 80-120 A. D.; Balmuildy (p. 70, 2), 140-180 A. D. Elsewhere in Britain he has been noted at Corbridge, Leicester, and Saffron Walden Museum on Drag. 31, at York on 18/31, and in London from Leadenhall Street on 33 and London Wall on a large dish. The first half of the second century would seem to be his period.

*C. I. L.* xiii, 10010, 272 (Clermont, Fégréac, Boulogne, Paris, and Soissons).

7. (A). BASSI. 24/25 or Hofheim 6. Large, thin. Pit 14, 18 ft. down. Claudian.

Potters of this name worked at La Graufesenque, Lezoux, and Westerndorf. The above stamp belongs to the first named, where a family of potters turned out large quantities of vessels from the time of Tiberius to that of the Flavian emperors (Ritterling,

*Hofheim*, p. 249). At least twenty-three stamps have been found in London alone. There are many pre-Flavian datings on the Continent, but in Britain the only datable site so far seems to have been Wroxeter (1914, p. 44, 226), where two stamps were assigned to the latter part of the first century and to 90-130 A. D. respectively.

The Drag. forms used at the South Gaulish pottery were 15, 18, 18/31, 24/25, 27, 29, 31, 33.

Déch. i, 256; *C. I. L.* xiii, 10010, 276; ii, 4970, 83; iii, 12014, 16; vii, 1336, 135; xv, 5059; Walters, M. 786-791, 916-17, 929; Oswald and Pryce, pp. 52, 78.

8. (A) BISSVNI. 27. Large. East of site 1.

A Gaulish potter of Vespasianic date according to Knorr (*Rottweil*, p. 57). He used Drag. forms 27 and 33.

In Britain the stamp has been found at Colchester, Hambleden, Leicester, and London (Guildhall Museum).

*C. I. L.* xiii, 10010, 314; vii, 1336, 157; xii, 5686, 134.

9. (A) BVCCIO. Hofheim 1. Pit 14, 18 ft. down. Claudian.

The plate indicates a first-century date, but the potter is difficult to identify. Excluding the late Rheinzabern stamp BVCCIO FECIT (Lud. i, 12, Oelmann, *Niederbieber*, p. 12, 9), it might be one of Buccus, reading BVCCI O or OF (the end being broken). A BVCCVS at Rottweil is given as probably Vespasianic (Knorr, *Rottweil*, p. 57) and BVCCVS F on 27 at Corbridge as late Flavian (*Report* 1910, p. 57). BVCCAS on 27 is of the first century at Neuss (*Bonn. Jahrb.*, 111/12, 338). BVCCV2 F and BVCCAS at Stockstadt (*O. R. L.* xxxiii, p. 101) is stated to be an East Gaulish potter of the beginning of the second century (La Madeleine, Fölzer, p. 9). The only similar stamp is from Vechten, undated. See stamp 36 (B) for remarks on the form.

*C. I. L.* xiii, 10010, 365.


10. (A) = CA·DCA·TIF =. 33. Large, brownish-red glaze. X scratched on foot-ring inside. Site 1, room 8.

A Gaulish potter of about the second and third quarters of the second century. In Britain his stamps have appeared at Castlecary, Corbridge (2), Lancaster, Silchester (4) and York. His Drag. forms are 27, 31, 33, 38.

*C. I. L.* xiii, 10010, 393; vii, 1336, 200; May, *Silchester*, p. 209.

The stamps OS·BIMC·ADC (London Museum) and CADCATI·MOSI (Leicester), both on 31 or 18/31, suggest partnerships with this potter at the same period.

64 REPORTS OF THE SOCIETY OF ANTIQUARIES

11. (A) OF CALV/. 18. Site 1, room 7, low level.  
 CALVI. 18. Thick. Site 1.  
 OF CAL/. 18. Pit 8, 14 ft. to 16 ft. down, late first and second century.  
 O  CAL. 18. Thin base, stamped within circle and rouletted ring in a deposit assigned to the second half of the first century. Site 1, room 6.  
 (B) OF·CALVI. 18. Slightly coned. Pit 2, 16 ft. to 16½ ft. down, 80-110 A.D.  
 (C) OFCALVI. Quarter round fillet plate (cf. Drag. 15), fine glaze. Well 1, 21 ft. to 22 ft. down. Late first and early second century.  
 OFCALVI. 27. Large, stamped across a small circle. Site 1, room 6. In a deposit mostly of first-century date.

Calvus, a La Graufesenque potter, flourished in the Flavian period (Ritterling, *Hofheim*, p. 249) on the Continent. In Britain he appears to be Domitianic or even slightly later. Site-dating: Corbridge, 90-105 A.D. (*Report* 1912, p. 43): G.P.O., 70-100 A.D. (*Arch.* lxvi, p. 259): Wroxeter (1913-14), five times, dated 80 or 90 to 110 or 120 A.D. The stamp also occurs three times at Carlisle and once at Camelton (*Arch.* lxiv, 300-1, 309), 75-85 A.D. He uses Drag. forms 15 (quarter round fillet), 16, 18, 18/31, 27, 32, 33, 40, and 29 (London Museum, A. 4467).

*C. I. L.* xiii, 10010, 412: vii, 1336, 218; xii, 4686, 159; Oswald and Pryce, pp. 52, 79.

12. (A) CASSIVSFE. 33. Large cup, light glaze. North-west of site 1 in a deposit of the Antonine period.

An East Gaulish potter of the first half of second century (*O. R. L.*, *Faimingen*, p. 62; *O. R. L.*, *Zugmantel*, p. 134).

Site-dating: Praunheim, c. 90-150 A.D.; Neuss, c. 25-105 A.D. Saalburg, in ditch of earth fort, Hadrianic. Curle places him in the first half of second century (*Newstead*, p. 233). His Drag. forms are 18, 18/31, 27, 31, 32, 33.

*C. I. L.* xiii, 10010, 475; vii, 1336, 254; Oswald and Pryce, p. 35.

13. (A) CATIA /, large, flat plate. North-west of site 1 near north wall of fort.

Catianus was a maker of plain pottery of Lezoux, working in the second half of second century. His chief dating is derived from the Pudding-pan Rock (140/150-190 A.D.), where nine of his stamps were found, viz. on Drag. 79 (2), 80 (6), and a peculiar small vessel 51/80, resembling Lud., Tf'.

He also used Drag. 27, 31, 32, 33, 38. In Britain other stamps of his have been found at Carlisle, Cirencester, Leicester, Newcastle, York (2), and Wroxeter.

*Proc. Soc. Ant.* xxii, pp. 401, 403, 404; *C. I. L.* xiii, 10010, 485; xii, 5686, 202-3; Oswald and Pryce, p. 62.

14. (A)  $\text{CEL}21\cdot$  (retro) Hofheim 9<sup>A</sup>. Cf. Drag. 8. Thick cup, bright glaze. In lowest road metalling, west gateway.

The potter Celsus, probably South Gaulish, is to be distinguished from later potters of the same name working at Lezoux, in East Gaul and (or) Rheinzabern. His use of this Hofheim form and the occurrence of his stamps (two) at Sels tiley place him in the Claudian period (*Bonn. Jahrb.* 111/112, p. 339). The same cup is used by Ardacus (see above) and Darra, two Claudian potters, also found at Sels tiley (Ritterling, *Hofheim*, p. 203). This is the first record of his retro stamp in Britain. On the Continent it has been noted with reversed S as here, at Arles, Mainz, Rottenburg, and Vechten, and Orleans Museum.

*C. I. L.* xiii, 10010, 523; ii, 6257, 43; xii, 5686, 218, 380; Oswald and Pryce, p. 177.

15. (A)  $\text{OF C}11\text{N}$  (retro). 27. Large, stamped within small circular groove. Pit 2, 10 ft. down in a deposit mostly of second-century date.

This stamp, perhaps fully  $\text{OF CENSORINI}$ , belongs to a La Graufesenque potter, who is dated on the Continent 70-85 A.D. (Knorr, *T. S.*, p. 6) and in Britain to the end of the first century. Site-dating: Corbridge,  $\text{OF} \cdot \text{CEN}$  on 29, 90-105 A.D. (*Report* 1912, pp. 43, 51-2); Wroxeter,  $\text{OF C}11\text{N}$  on 18, probably 80-105 A.D., and  $\text{C}11\text{N} \cdot \text{F}$  (retro) on 27 (1914, p. 45, 228 A and p. 53). The stamps are also found on Drag. 18/31 and 33 (GEN, Barhill).

*C. I. L.* xiii, 10010, 528 (esp. b, d<sup>2</sup>, q, v<sup>6</sup>), 956; vii, 1336, 286; xii, 5686, 220, 386.

16. (A)  $\text{OF CENS}$ . 18. Dull glaze, rough lettering.  $\text{NEM}$  scratched on underside of base. Site 1, room 3, in a deposit of late first-century date.

Ditto. 18. Good glaze. S. of site 1.

These stamps belong to a contemporary potter, and therefore are possibly identical with that of the preceding, though Fölzer, judging by their distribution, thinks he may have worked at Vichy or in the neighbourhood of Rheims. Stamps are found on Drag. 18 and 18/31, on the latter at Neuss (*Bonn. Jahrb.* 111/112, p. 339).

Fölzer, *Ostgallische Sigillata-Manufacturen*, pp. 66-7; *C. I. L.* xiii, 10010, 534-5.



17. (A) OF COELI. 27. Large, dull glaze. Site 1, low level.  
 Coelius made decorated and plain pottery at La Graufesenque (Déch. i, 83). Site-dating: Neuss, on Drag. 27, 31, first century; Rottweil, on 29, early Vespasian (Knorr, p. 59); Carlisle, on 29, 70-80 A.D. (Bushe-Fox, *Arch.* lxiv, pp. 300-1); Wroxeter, on 29, latter part of first century (1912, p. 43). Another form, Drag. 33, bears his stamp in the Guildhall Museum.  
*C. I. L.* xiii, 10010, 604; ii, 4970, 136; xii, 5686, 253; Oswald and Pryce, pp. 57, 80.

18. (A) COSRVF. 27. Glaze slightly orange, lettering much perished. South of site 1.  
 Ditto. 27. Same size but better glaze and finer paste. Site 1, room 8.

The name Cosius Rufus probably represents not a partnership, but a Gaul with two names (*C. I. L.* xiii, Preface, p. 120). He made both decorated and plain vessels and was a potter of La Graufesenque, apparently not identical, though contemporary, with Cosius Rufinus,<sup>1</sup> as there are two distinct potters, Rufus and Rufinus of La Graufesenque.

Site-dating: Ritterling considers he is not before 80 A.D. (Ritterling, *Hofheim*, p. 250). Camelon on 18 and 29, Carlisle on 29, c. 75-85 (Bushe-Fox, *Arch.* lxiv, pp. 299, 308). Newstead (pp. 228, 234) on 18, 80-110 A.D. Wroxeter (1912-14) on 18 and 27, 80-120 and 90-110 A.D.

*C. I. L.* xiii, 10010, 655; ii, 6349, 14; xii, 5686, 266; Oswald and Pryce, pp. 57, 80.

19. (A) COSIRVFINI. 18. Large size with good bright red glaze. Pit 7 in the filling near the bottom.

See remarks under Cosius Rufus, no. 18 (A). There is the same stamp on a 31 in the British Museum (Walters, M. 997). At Wroxeter (1913, p. 41) a stamp of this potter was found in a deposit dated 90-110 A.D.

*C. I. L.* xiii, 10010, 654; vii, 1336, 349.

20. (A) OF CO- / 18. Block lettering. = OF COTTO. Site 1.  
 A Gaulish potter ('Rutenian', Walters, M. 634) of the end of first century who made plain wares.

Site-dating: Newstead (p. 234), end of first century, with stamps DAGO and OF IVCVN; Wroxeter (1913-14, 166), two, 80-120 A.D. Drag. forms used: 18, 18/31, 27. Lud. iv, 45.

<sup>1</sup> Some of the abbreviated stamps of these potters may belong to either, and the Corpus has been followed in this instance.

*C. I. L.* xiii, 10010, 678; ii, 6349, 15; vii, 1336, 353; Oswald and Pryce, p. 57.

21. (A) OF CREST. 18. Within large circle. Site 1, well 1, 16 ft. down. Late first, early second century.

A potter or a family of the name Crestio or Crestus was active at La Graufesenque from the Claudian to the Flavian period, but in Britain is as yet only datable to the latter. On the Continent many stamps have been noted at the early cemetery of Andernach, at Wiesbaden (37-69 A.D.), at the legionary camp of Neuss, and at Sels (Déch. i, 94; Ritterling, *Hofheim*, p. 245). At Hofheim both periods (40-83 A.D.) are represented. In Britain the site-dating is: Carlisle, two on Drag. 29, 75-85 A.D. (*Arch.* lxiv, 299); Wroxeter, 1913-14 on Drag. 18 and 27, 80-120 A.D. (4 separate datings), and 1914 on Drag. 29, 80-110 A.D.; at G.P.O., late first century in three different pits, associated with stamps of Caius, Calvus, Primus, and Vitalis (Lambert, *Arch.* lxvi, pp. 258-60). At least 38 stamps of this name have been found in London alone. The Drag. forms used are: 4/8 (?), 5, 18, 18/31, 24/25, 27, 29, 33, and 37 (?).

Déch. i, 268; Geissner, *Mainzer-Stempel*, 506-22; Lud. iii, 47; *C. I. L.* xiii, 10010, 697-8, 10011, 187; ii, 4970, 154, 6257, 54-6; iii, 6010, 75; vii, 1336, 365, 370, 372; 1337, 25; xii, 5686, 277-8; xv, 5096, 5157; Oswald and Pryce, pp. 52, 80.

22. (A) CVRMILIV. 18/31. Thinnish plate. Site 1.

Curmillus is a little-known potter of Lezoux, where a mould of his (Drag. 37) has been found (Déch. i, 268). The Guildhall Museum has a stamp CVRMILLI on 27. His date is probably in the first half of second century.

*C. I. L.* xiii, 10010, 729; xii, 5686, 292; Oswald and Pryce, p. 112.

23. (A) DIVICATIM. 33. Stamped across small circle, light, thinnish glaze. Site 1.

(B) DIVICATVS. 38. Indifferent glaze. East of site 1.

A potter of the Antonine period probably from Lezoux. Site-dating: Barhill, on 33 (Macdonald, *Roman Wall in Scotland*, 373), Antonine; Newstead (p. 235), 140-180 A.D.; Wroxeter (1913, p. 41, no. 45 A), in a pit with pottery mostly of second and third century. The Drag. forms recorded are: 18/31, 27, 31, 33, 38.

*C. I. L.* xiii, 10010, 788; vii, 1336, 414-15.

24. (A) DONTIO/. 33. Large, very fair glaze. Very small lettering, stamped across a slightly domed surface. = DONTIO IIC (i. e. DONTIO FEC) fully. Site 1, room 3, in a deposit belonging to the last twenty years of the first century, but in which were a few later fragments of pottery.

Dontio, found at Neuss, may be an early potter of Lezoux (Lambert, *Arch.* lxxvi, 240). He uses Drag. 27 (more commonly) and 33, and has been found in Britain at Chester (2), Leicester, London (7), and Silchester. Ludowici notes him as 'Gaulish' at Rhein Zabern on  $\mathfrak{G}b$  (Drag. 27) and  $Bb$  (Drag. 46).

*Bonn. Jahrb.* III/112, 340; Lud. i, 60; iii, 47; *C. I. L.* ii, 6257, 149; xii, 5686, 321; xiii, 10010, 813.

25. (A) DOVIICVS. 31. Site 1, room 6, top soil.  
See decorated stamps 2 (A).

26. (A) ELV\ . 38. Dullish, patchy, brown-red glaze. = ELVILLI. Site 1, room 6. In a deposit mostly of the second half of the first century, but in which were some later fragments of pottery.

Probably a Lezoux potter, who uses Drag. 31, 33, and 80 (?). Seven stamps were found at Wroxeter in 1924 in a group dated about 160 A.D. by Mr. D. Atkinson.

Also found in Britain at Cirencester, Colchester, Corbridge, Litlington near Royston, London, Westbury (Devizes Mus.), and York (2).

*Arch. Ael.* 1915, 280; *Birmingham Post*, 15 July, 1924; *C. I. L.* vii, 1336, 439; xii, 5686, 327; xiii, 10010, 845.

27. (A) OFFEL/. 27. = OFFELICIS or OFFELIX. Site 1.  
Several South Gaulish potters of this name, mostly of the first century A.D. OFFELICIS is dated 60-70 A.D. (Knorr, *Terra Sigillata*, (1919) p. 6), while the stamp OFFELIX is found at Sels tiley, and is probably Claudian. Potters of this name were certainly working from the pre-Flavian into the Flavian period.

Oswald and Pryce, p. 52; Ritterling, *Hofheim*, 238, 245; Déch. i, 272; *C. I. L.* ii, 4970, 189 and 6257; vii, 1336, 451; xii, 5686, 358; xiii, 10010, 889; xv, 5211 q.

28. (A) FIRMV/. 33. Large. Site 1, room 7.

This is Ludowici's stamp b or d of the Rhein Zabern potter Firmus, who also appears to have worked in East Gaul and at Westerndorf. He is found at Newstead (*Report*, p. 236) in the second fort and is dated by Reubel (*Römische Töpfer in Rhein Zabern*, p. 341) 150-170 A.D.

Also found at Corbridge, London, and Silchester.

*Arch. Ael.* 1915, 280; Oswald and Pryce, p. 63; Lud. ii, p. 271; *C. I. L.* iii, 6010, 89; xiii, 10010, 901.

29. (A) OFRO/. 18. Slightly coned. = OFRONTINI. Site 1, room 3, deposit belonging to the last twenty years of the first century, but in which were a few later fragments of pottery.

A La Graufesenque potter of the Flavian period, whom Ritterling considers to be after 80 A.D. (*Hofheim*, p. 250). His stamps are found in the ditch of the early fort at Newstead (*Report*, p. 236), at Neuss (3 stamps), in the Bregenz cellar-find dated about 80-110 A.D., and at Wroxeter also 80-120 (three datings). Frontinus uses Drag. shapes 18, 18/31, 27, 29, 31, 33, 37.

Oswald and Pryce, p. 58; *Bonn. Jahrb.* 111/112, pp. 340, 350; *Wroxeter*, 1912, p. 52; 1913, p. 41; 1914, p. 52; *C. I. L.* ii, 4970, 204; iii, 6010, 92; vii, 1336, 469; xii, 5686, 369; xiii, 10010, 920.

30. (A) GERMANI\ . 18/31 = GERMANIF. Site 1.

Germanus was a La Graufesenque potter who began working at the end of the Neronian, but whose chief activity lay in the Flavian period (Ritterling, *Hofheim*, pp. 249-50). His numerous stamps are found at Hofheim, but only in the second period, at Pompeii, in the legionary camp at Neuss, and at Wiesbaden in both periods (37-69 and 83-122 A.D.), but more frequently in the later one.

Mr. D. Atkinson suggests the date 60-85 A.D. (May, *Cat. Roman Pottery, Tullie House, Carlisle*, p. 16, note †).

The Drag. shapes used are 16, 18, 18/31, 27, 29, 30, 37, 78.

Oswald and Pryce, p. 55; *Déch.* i, 273-5; *Bonn. Jahrb.* 111/112, 340; *C. I. L.* ii, 4970, 217 and 6257, 87; iii, 6010, 97; vii, 1336, 488; xi, 6700, 313; xii, 5636, 387; xiii, 10010, 963 and 10011, 205-6.

31. (A) GRANIO/. 33. Thin. Site 1.

The rare stamp GRANIOM (reversed) on 27 was found at Rheinzabern (Lud. iv, 17) in grave 325 with stamps of TRITVSF on 33 (?), SACIANT and TOCCA on 18/31, IVNIVS and SECVND on 27, and with decorated fragments, probably of Janus and Satto. Granio may therefore be placed in the first half of second century, most probably in the reign of Hadrian. A similar stamp on 33 (poor, dull glaze) appeared at the Weber Sale, 1919 (Cat. no. 48). Granio must be distinguished from the Lezoux decorated and

plain potter Granius (Déch. i, 275, *C. I. L.* xiii, 10010, 977).  
Granio on 31 was found at Corbridge (*Arch. Ael.* 1915, 281).

*C. I. L.* xii, 5686, 393 ; xiii, 10010, 977 b, d, e.

32. (A) OF·IVCVN. 27. Site 1, room 2, in a deposit dated  
80-110.

(B) NDV. 18. Fragment of very thin base. Site 1.

These two stamps belong to the South Gaulish potter Jucundus, who, like Germanus, began working in pre-Flavian, but flourished in Flavian, times (Ritterling, *Hofheim*, 249). Nine of his stamps were found in the legionary camp at Neuss, but they are more numerous in the Flavian layer at Wiesbaden. In Britain his stamps belong to the early fort at Newstead (*Report*, p. 237), and at Wroxeter (1913, p. 30, on Drag. 29) to 80-110 A.D.

Oswald and Pryce, p. 53 ; *Bonn. Jahrb.* 111/112, 341 ; Déch. i, 276-7 ; *C. I. L.* ii, 4970, 243 ; iii, 6010, 103 ; vii, 1336, 519 ; xiii, 10010, 1061 ; xv, 5273 b, c, d.

33. (A) IVTIOF/. 31. Coarse, indifferent glaze. West of  
site 1. = IVSTI OFI fully.

There are at least three, possibly five, different potters named Justus, many of their stamps being difficult to assign (Drexel, *Faimingen*, *O. R. L.* xxxv, p. 64). Discarding the Flavian potter of La Graufesenque as unsuited to the shape and glaze, and the East Gaulish and Rheinzabern potter or potters who stamp IVSTVS, we are left with the Lezoux potter of Antonine date.

IVTIOF is recorded at Friedberg, Saalburg in castello, Faimingen (*op. cit.*) and in the Mainz Museum, IVSTI OFI in Speier Museum, IVSTI OF at Trion, (3 ex.), Vechten (4 ex.) and Basle Museum, and IVTIO O at Trion (2 ex.). IVSTI·MA from Pudding-pan Rock is probably identical.

*C. I. L.* xiii, 10010, 1092.

34. (A) L·I·F. 33. Small, slightly domed, dull glaze. Site 1, room 7.

This stamp, doubtless representing the initials of two names = L·I·F(ecit), is only known from the two examples found at Bordeaux, which suggests a Montans origin. It is probably of late first-century date. It is noticeable how many stamps, of which the first name has the initial L, appear to come from the Montans potteries. For instance, L·I AC and L I CRE are also found at Bordeaux only, L·L·FLOR at Bordeaux and Agen, L·A·ANT at Lectoure only, L·A·ATILI at Bordeaux and Lectoure, L·EPPI at Montans, Bordeaux, and Lectoure, L·CRE at Montans and Bordeaux, while LCRF (probably identical with L·CRE) and L·I·R occur at Montans only. L·APRON is also a Montans potter.

*C. I. L.* xiii, 10010, 993.

35. (A) LALV/. 27. Thick cup, dullish glaze. = LALVS F.  
Site I.

Lalus or Lallus, to be distinguished from LALLVS FEC of Westerndorf, is a Lezoux potter of Hadrianic date, who made both decorated and plain vessels. His mould of Drag. 37 was found by Plicque at Lezoux (Déch. i, 279). The stamp LALLI·MA has been noted at Pfünz on a coned plate, at Colchester on 32 (?) (Walters, M. 2021), and in London on 38 (?) (N.S.D.C. 134, Guildhall M.). If these are to be assigned to the same potter, his period may possibly extend into the reign of Pius.

Oswald and Pryce, p. 116; Pfünz, *O. R. L.* 73, p. 48, no. 62; *C. I. L.* ii, 4970, 259; xiii, 10010, 1112.

36. (A) / LICN. 24/25. Brilliant glaze, small lettering. Pit 2,  
20-2 ft. down, in association with a coin of Claudius I.  
(B) OF LICIN. Hofheim I. Pit 14, 12-18 ft. down.  
Claudian.

The La Graufesenque potter Licinus is of pre-Flavian date, if not Claudian only, as shown by the occurrence of his stamps at Sels tilery, Wiesbaden (earlier stratum), Xanten, and Hofheim.

Drag. 24/25 is very common at Hofheim, but only in the earlier camp (Ritterling, *Hofheim*, p. 207).

A Hofheim I plate was found with a MOMO stamp at Sels tilery. The shape is assigned to the period of Claudius-Nero by Knorr (*Aislingen*, xv, 18).

Licinus also uses Drag. 18, 27, 29, Hofheim 9 b, and the quarter-round fillet plate.

Oswald and Pryce, p. 51; Ritterling, *Hofheim*, p. 245; *C. I. L.* ii, 4970, 263-4 b, 6257, 104 and 6349, 25; vii, 1336, 557-60; xii, 5686, 485-6; xiii, 10010, 1019, 1142-5.

37. (A) LVG U\ (retro). 32. Thick ware, good glaze. = LVGUPEC  
fully. Pit 2, 10 ft. down. In a deposit mostly of the  
second century.

Lucupec is stated to be an East Gaulish potter who worked in the first half of second century A. D. (Drexel, *Stockstadt*, *O. R. L.* xxxiii, p. 103, no. 73). He is found at the German forts of Grimmlinghausen, Gross-Krotzenburg, Friedberg, Stockstadt, and Zugmantel, and also at Neuss (*Bonn. Jahrb.* 111/112, 341). Eight of his stamps are recorded at Reims, which suggests that Lavoye was the site of his pottery works. He also used Drag. shapes 27 and 31.

*C. I. L.* xiii, 10010, 1175.

38. (A) MACRINVS. 33. Partly misstruck. Site 1, 9.

A stamp of the potter of Lezoux, not of La Graufesenque.

At Wroxeter (1912, p. 36, no. 68) a similar stamp was found in a burnt layer of about the Antonine period and at Astwick, Beds. (*V. C. H. Beds.*, ii, 4) in a group datable about 140-160 A. D. Last summer (1924) a nest of vessels including one with his stamp was found at Wroxeter and dated about 160 A. D. (Reference under Elvillus.) Macrinus of Lezoux also uses Drag. shapes 18/31 and 31, and appears to have worked for another Lezoux potter, Eppillus.

*C. I. L.* vii, 1336, 603; xii, 5686, 521; xiii, 10010, 1214-15.

39. (A) OF MASCL. 24/25. Small lettering. Pit 14, 12-18 ft. down. Claudian.

Whether the stamps of Masclus and Masculus, both coming from La Graufesenque, belong to the same potter or family of potters is uncertain, but those of Masclus represent earlier work. Masclus had four stamps at Sels, Masculus none. The decorated bowls of the former are pre-Flavian, if not Claudian, in design, whereas those of the latter show Domitianic details, such as the use of small grass plants (*D. Atkinson, J. R. S.* iv, pt. i, p. 35). But the plain stamps of Masculus appear on earlier sites, e. g. at the legionary camp of Neuss and the earlier stratum at Wiesbaden. Knorr (*Rottweil*, p. 26) considers that Masclus may very probably be dated 50-70 A. D. Other shapes used by Masclus are Drag. 18, 27, 29, 30, and Ritterling 8 (early Drag. 40).

Oswald and Pryce, p. 53; Déch. i, 285-6; Walters, M. 406, 443-4, 669, 817-18; *C. I. L.* ii, 4970, 306, 4971, 10 and 6257, 113-14; xii, 5686, 560-1; xiii, 10010, 1297 and 10011, 232-3.

40. (A) OF MODE. 27. Large. Small lettering, good glaze. Site 1, 9.

The La Graufesenque potter Modestus appears to belong chiefly to the pre-Flavian period, his earliest dating being that of Sels tiler (Tiberian), where six of his stamps were found. Other pre-Flavian sites are Neuss, legionary camp (10 stamps), Wiesbaden, earlier stratum, and Andernach. But at Hofheim the thirteen stamps are not limited to the time of the earlier camp. In Britain, 80-120 A. D. is assigned to a Wroxeter stamp (1913, p. 36, no. 191), and at the G.P.O. one was found in a pit with stamps of Licinius, Sentrus, and Passienus, and dated by Mr. Lambert 50-80 A. D. or perhaps a little later (*Arch.* lxi, p. 256). Other shapes thus stamped are Drag. 3, 19, 27, 29, and the quarter-round fillet plate.

Oswald and Pryce, p. 53; *Bonn. Jahrb.* 111/112, 343; *Lud.* iv, 43; Walters, M. 606, 673-9, 822-7; *C. I. L.* ii, 4970, 329 and 6257, 124; vii, 1336, 719-20; xii, 5686, 599; xiii, 10010, 1369-70, 1372 and 10011, 237; xv, 5353.

41. (A)  $\text{O} \overline{\text{W}} \overline{\text{M}}$ . Hofheim 9 A. = OMOM. Pit 14, 21 ft. 6 in. down. Claudian.

(B)  $\text{O} \overline{\text{I}} \overline{\text{M}} \text{O} \overline{\text{M}}$ . 27? Large, slightly domed, high grooved foot-ring. Beneath is scratched  $\text{A}$ . Site 1.

See decorated stamps, no. 6 (A).

42. (A)  $\text{D} \overline{\text{F}} \overline{\text{M}} \overline{\text{V}} \overline{\text{A}}$ . 18 thin. } Site 1, room 6. In a deposit  
 $\overline{\text{V}} \overline{\text{R}} \overline{\text{R}} \overline{\text{A}}$ . 18 similar. } mostly of first-century date.

Murranus is represented on such pre-Flavian sites as Sels tilery (6), Neuss, legionary camp (2), and Wiesbaden earlier stratum (4), but also at Rottweil, where he is classed as early Vespasianic (Knorr, *Rottweil*, p. 64).

At Corbridge too (*Arch. Ael.* xii, 283) he is definitely stated to be 'Flavian, not pre-Flavian'. So his South Gaulish pottery, from which twenty-nine stamps are known in London alone, appears to cover the period from Claudius to Vespasian.

Oswald and Pryce, pp. 53-4; *Arch.* lxvi, 239, 256, 268; Walters, M. 383, 681-2, 835-6; *C. I. L.* ii, 4970, 335 and 6257, 127-8; vii, 1336, 740-2; xii, 5686, 612; xiii, 10010, 1394.

43. (A)  $\text{NICEPHOR} \cdot \overline{\text{I}}$ . 18/31, good glaze. = NICEPHOR · F. Site 1, room 8.

This potter probably worked about the end of the first century A. D. (*Wroxeter*, 1912, p. 56, no. 81).

Dating sites: Heddernheim, in a grave deposit, 25-105 A. D. (*Bonn. Jahrb.* xcix, 1896, p. 54); Neuss, c. 70-110 A. D. (*B. J.* 111/112, 343); Wroxeter (1913, p. 42), in a deposit before 130 A. D.; Corbridge (*Report*, 1911, p. 182, fig. 8, no. 116) on a strap-handled cup, where it is placed in the first century.

Oswald and Pryce, p. 59; *C. I. L.* ii, 4974, 29; iii, 6010, 151; vii, 1336, 757; xii, 5686, 636; xiii, 10010, 1425-6.

44. (A)  $\overline{\text{N}} \overline{\text{C}}$ . 24/25 large. =  $\overline{\text{N}} \overline{\text{I}} \overline{\text{G}} \overline{\text{R}} \overline{\text{I}}$  fully. Site 1, room 1, top soil.

Four stamps of Niger were found at Banassac and one of the partnership  $\overline{\text{N}} \overline{\text{I}} \overline{\text{G}} \overline{\text{R}} \overline{\text{I}} \cdot \overline{\text{A}} \overline{\text{N}} \overline{\text{D}}$  at La Graufesenque.

He appears to have been, like Murranus, a pre-Flavian potter who continued into the reign of Vespasian. His stamps are recorded at Sels tilery (2), Neuss, legionary, camp and Wiesbaden (earlier stratum), and also at Windisch and Rottweil. The ten



Hofheim stamps, which include some of his partnership, cover both periods of that fort. In the London Museum there is a quarter round fillet plate (A 21097), probably pre-Flavian (*Wroxeter*, 1914, p. 42), and a Drag. 29 (A 206) with early Vespasianic decoration. Knorr (*T. S.*, 1919, pl. 61) considers his decorated bowls to be of the Nero-Vespasian period.

Oswald and Pryce, p. 54; Déch. i, 288; *C. I. L.* ii, 4970, 345; vii, 1336, 763; xii, 5686, 639; xiii, 10010, 1428-9.

45. (A) NOM. 27. Small lettering. Site 1, room 3, low level. Second half of first century.

This is possibly the first stamp noted in Britain of the little-known South Gaulish potter Nomus. He probably worked at Montans, though also found at La Graufesenque. A Drag. 37 bowl from Montans, stamped on the inside, shows transitional decoration and may therefore be assigned to the Flavian period.

Déch. i, 288; *C. I. L.* xiii, 10010, 1439.

46. (A) OF P<sup>AR</sup>C. 27. Small, bright glaze. = OF PATRIC. Site 1, room 6. In a deposit assigned to 80-120 A. D.

(B) OF PAT. 27. Pit 2, 16 ft. to 16 ft. 6 in. down. 80-110 A. D.

(C) /F PARIC. 18. Pit 12, 20 ft. 6 in. to 25 ft. down. First and early second century.

Patricius of La Graufesenque began working under Nero, but flourished in the Flavian period (Ritterling, *Hofheim*, p. 249). The evidence is, that while his stamps appear in the Neuss legionary camp and Wiesbaden earlier stratum, they are much commoner in the Domitian-Trajan period of the latter, and at Hofheim are confined to the later camp (74-83 A. D.). A Drag. 29 bowl in the Pompeian hoard of 77-79 A. D. leads Mr. D. Atkinson to place him about 60-85 A. D. (*J. R. S.* iv, i, p. 34). His stamps, though common in Britain, may not have reached this island until Flavian times. One was found at Carlisle (dating from 79 A. D.) and two datings were obtained at Wroxeter (1912, p. 57; 1914, p. 53), viz. in a group with OF COTOI, OF MO, and VITALIS M, probably about 75-85 A. D. and 80-120 A. D. There appear to be other potters of the same name, one of whom, working in the first half of the second century, stamps PATRICIVS F on 31 (*Newstead*, p. 238), PATRICI M on a coned plate at Zugmantel (*O. R. L.* xxxii, p. 144, no. 261), 'beginning of second century', and on 18 at Wroxeter (1914, p. 58, 87 (D)) before 150 A. D., while PATRICIVS and PATRICI M are represented on Drag. 38 at

Carlisle (May, *Tullie Ho. Cat.*, p. 76) and Kenchester (*Woolhope Club Report*, 1916, p. 74) respectively.

Forrer (p. 234) also mentions a Patricius as found at Westerndorf towards the end of the second century.

Oswald and Pryce, p. 56; Déch. i, 294; *C. I. L.* ii, 4970, 376 and 6257, 138; iii, 12014, 418 c; vii, 1336, 806-11; xii, 5686, 678; xiii, 10010, 1511.

47. ΠΑΥΚΤΙ. 33. Thick, large, coarse ware. East of site 1.

A stamp of the Lezoux potter who made decorated and plain vessels in the second half of the second century A. D. Five of his stamps on Drag. 79 or 80 have been dredged from the Puddingpan Rock (*Proc. Soc. Ant.* xxii, 268) and another comes from the Flavion Cemetery (Namur), where the latest coin is dated 193 A. D. His ware appears in the Wroxeter hoard (1924), c. 160 A. D. His use of Drag. 38 and 44 also points to the same period.

Oswald and Pryce, p. 63; Déch. i, 294. Walters, M. 1747; *C. I. L.* iii, 6010, 161; xiii, 10010, 1520 and 10011, 99, 123.

48. (A) ΠΛΛ. 33. Good glaze. = PLACIDVS. Site 1.

Placidus is a potter of East Gaulish origin whose only other shapes known are Drag. 18/31 and 27. His stamp has been found at Heddernheim (*Hedd. Mitt.* v, p. 47) in a cemetery dating from Domitian to early Trajan. But his flourishing period was that of Hadrian and Pius (*O. R. L., Ems*, xxxvi, pp. 31, 42; *Stockstadt*, xxxiii, pp. 105, 103; *Zugmantel*, pp. 145, 271-3, etc.). He is recorded on the Outer Limes (*O. R. L., Cannstatt*, xxviii, pp. 56, 117). At Rheinzabern he is associated in grave 301 with a decorated bowl of Janus (120-145 A. D., Reubel, p. 38, or 130-150 A. D., *O. R. L., Zugmantel*, p. 117) and in grave 256 with the Rheinzabern Victorinus (Antonine, Reubel, p. 55). Lud. iii, pp. 52, 190, 194, 198; *C. I. L.* iii, 6010, 164; vii, 1336, 833 (York); xiii, 10010, 1537.

49. (A) ΠΠΕΙ. 18. = OF PONTEI. Site 1, room 6. In a deposit mostly of first-century date.

Ponteius is a South Gaulish potter of late first-century date, whose stamp has hitherto been recorded only on Drag. 18. He is noted twice at Neuss (*Bonn. Jahrb.* III/II2, 344). Ritterling (*Hofheim*, p. 250) considers that he is not before 80 A. D. Six of his stamps have been found in London, one being in the British Museum (Walters, M. 703), one in the London Museum (A 1205), and four at the Guildhall.

*Arch.* lxvi, pp. 239, 268; *C. I. L.* vii, 1336, 836 a; xii, 5686, 697; xiii, 10010, 1543.

50. (A) OF PRIMI. 27. Medium large. Site 1, room 2 B. In a deposit dated 75-85.

(B) OF PRIMI. 18. Good glaze, thin pottery, fine lettering. North-west of site 1, near north wall of fort.

Vessels of a La Graufesenque potter or potters of this name were produced in great abundance from Claudius until the Flavians, though more especially in pre-Flavian times. Hofheim (11), Neuss legionary camp (12), Sels tiliary (12), and Wiesbaden (many) in both strata are represented, and Rottweil (Knorr, p. 64) in the Vespasianic period. In Britain site-dating has so far assigned these stamps to the late first century A.D., e.g. at G.P.O. (*Arch.* lxvi, p. 259) and thrice at Wroxeter (1912, p. 46; 1913, p. 38).

Oswald and Pryce, p. 54; *Déch.* i, 295; *Lud.* i, 60, ii, 54; *C. I. L.* ii, 4970, 404, 6257, 152 and 6349, 32; iii, 6010, 172; vii, 1336, 856-65; xii, 5686, 706, 714; xiii, 10010, 1569; xii, 5462 (Rome).

51. (A) QVINTIO. 27. Large. Pit 2, 16 ft. down. 80-110.

Quintio, of unknown origin, is only recorded on Drag. 27 and 29. Mr. Bushe-Fox (*Wroxeter*, 1914, p. 49, 254) says the decoration on a Drag. 29 of Quintio in the Guildhall Museum suggests the period of Vespasian. In Britain his stamps have been found at Cirencester, Colchester (2), London (3, Guildhall Museum), York (2), and Wroxeter (2).

*C. I. L.* xii, 5686, 735 e; xiii, 10010, 1605.

52. (A) REGENVS. 18. Hofheim 2A<sup>c</sup>, good glaze, slightly coned, stamped within a circle and a rouletted ring. Site 1, low level.

Regenus was a Claudian potter of La Graufesenque who had most probably ceased working before 69 A.D. (Ritterling, *Hofheim*, p. 249). Site-dating: Hofheim and Wiesbaden earlier periods, Sels (4). In Britain his stamps have been found in the City and at Colchester (2).

*Arch.* lxvi, p. 268 (King William Street, London); *C. I. L.* ii, 4970, 424 b, c; iii, 6010, 177; vii, 1336, 904 (Colchester); xii, 5686, 741; xiii, 10010, 1617.

53. (A) O F RVFI. 18. Site 1, well 2, top.

(B) /RVFI. 27. Small. = OFRVFI. Near north wall of fort by postern gate, top soil.

Rufus was a La Graufesenque potter whose stamps were also found at Montans. He is probably identical with RVFFVS, but is to be distinguished from the Antonine potter who stamps

RVFFI M or MA. On the Continent he appears at Neuss (6), Windisch and Wiesbaden, and in Britain at Newstead (Curle, p. 240), presumably in the first period. He used Drag. shapes 18, 18/31, 24/25, 27, 29, 31, and 33. His chief output probably belonged to the Flavian period, though he may have been working a little earlier.

Oswald and Pryce, pp. 85, 122; Lud. iii, 46; *C. I. L.* ii, 4970, 444 and 6257, 164; vii, 1336, 934 b, 947; xii, 5686, 764; xiii, 10010, 1657, 1662.

54. (A) OF.RVFNI. Quarter round fillet plate. = OF.RVFÎNI.  
Pit 13, 18 ft. 4 in. to 23 ft. down. Late first and early second century.

The stamps of this La Graufesenque potter, though found in Nero's reign, e.g. at Neuss legionary camp (10) and in the earlier stratum of Wiesbaden, are chiefly to be assigned to the Flavian period (Ritterling, *Hofheim*, p. 249). This is shown by their appearance on the Continent at the Vespasianic camp at Hofheim, in the later stratum at Wiesbaden (85-122 A. D.) and at Rottweil (5 stamps, 'Vespasianic', Knorr, p. 65). Two Drag. 29 bowls were also included in the Pompeian hoard (77-79 A. D., Atkinson, *J. R. S.* iv, i, p. 33). In Britain a similar dating is indicated by stamps in the Agricolaean camp at Newstead (Curle, p. 240) and at Wroxeter (3 stamps, 75-100, 80-110/120 A. D., 1912-14, no. 102). A probable limit to his activities, as in the case of Germanus and Patricius, may be fixed by Knorr's dating, 60-85 A. D. (*Ristissen-Festschrift*, 1912, p. 57). There would appear to be a later East Gaulish potter Rufinus working in the first half of the second century. His stamps (with much larger lettering) are found on Drag. 31 within a hatched ring at Urspring dating shortly before its evacuation in 154 A. D. (*O. R. L.* lxvi a, p. 38, no. 2) and at Cannstatt (*O. R. L.* lix, pp. 58, 148, 150).

Oswald and Pryce, p. 56; *C. I. L.* ii, 4970, 436; iii, 6010, 186; vii, 1336, 937 c; xii, 5686, 759-61; xiii, 10010, 1659.

55. (A) OF. SABIN. 18. Site 1, room 3. In a deposit assigned to 80-100, but which contained a few later fragments of pottery.

The La Graufesenque potter Sabinus is chiefly Flavian, though two stamps were found in the early cemetery of Andernach (16-68 A. D., Déch. i, 94).

Site-dating: on the Continent, Bregenz (Cellar Find, c. 80-110 A. D.), Neuss, 5 stamps (*Bonn. Jahrb.* 111/112, 345), Pompeii (Déch. i, p. 95, fig. 63, and p. 96), and Cannstatt (Knorr, *Südgallische Rottweil*, p. 40, 'probably Domitianic'); in Britain, Newstead

(Curle, p. 240, 'end of first century') and Wroxeter (1912, 1914, no. 103, 80-110/120).

Other potters of the same name worked at Lezoux and Rheinzabern.

Oswald and Pryce, p. 59; Déch. i, 297; Lud. ii, 64; iii, 60; *C. I. L.* ii, 4970, 450 and 6349, 37; vii, 1336, 952-6; x, 8056, 315; xii, 5686, 772; xiii, 10010, 1682-3; xv, 5541 (Rome).

56. (A) SALVE. Hofheim 4 A (quarter round fillet plate), in tabella ansata. Pit 14, 8 ft.-12 ft. down. Claudian.

The Montans potter Salvetus is certainly pre-Flavian, possibly Tiberio-Claudian only. His period is fixed by five stamps found at Sels tiliary and another at Xanten of Claudio-Neronian date. In Britain he has been found at Colchester on Drag. 29 (1162.06) and in London on two plates similar to the Richborough specimen (Guildhall Museum), and on Drag. 24 (Walters, M. 776). All of these were probably imported soon after the Claudian invasion.

Oswald and Pryce, p. 51; Déch. i, 298; Lud. ii, 64; *C. I. L.* ii, 4970, 451; xii, 5686, 780; xiii, 10010, 1707 and 10011, 261.

57. (A) SECVDMA. 27. = [ ? OF ] SECVD(1)MA. East of site 1.

Though the La Graufesenque Secundus is recorded on various pre-Flavian sites, including Sels tiliary (twelve stamps), and is thought likely to have ceased working before 69 A.D. (Ritterling, *Hofheim*, p. 249), his wares, and especially his decorated bowls, were still being exported under Vespasian, e. g. to Pompeii (*J. R. S.* iv, i, p. 48, fig. 24) and to Rottweil (three stamps, Knorr, pp. 65-6). Soon after they must have reached British sites, such as Carlisle (three stamps, *Tullie Ho. Cat.*, p. 79), Newstead (Curle, p. 240), and Wroxeter (three stamps, all of late first to early second century, 1913-14, no. 212).

Oswald and Pryce, p. 54; Déch. i, 299; *C. I. L.* ii, 4970, 463 and 6257, 177; iii, 6010, 200; vii, 1336, 998-1004; xii, 5686, 801, 803; xiii, 10010, 1764, *m*<sup>4</sup>.

58. (A) SIINICIO·F. 18. Thin plate, very slightly domed. = SENICIO·F. Site 1, room 2, low level.

Senicio or Senecio of La Graufesenque belongs to the first half of the first century A.D. A Drag. 29 at Mainz (Ritterling, *Hofheim*, Abb. 49, Oswald and Pryce, iii, 5) is placed in the reign of Tiberius. Three stamps from Sels tiliary must be almost contemporary, and another is noted from the Claudian camp at Hofheim. Other stamps from Neuss, legionary camp, and

Wiesbaden, earlier stratum, are also probably corroborative. The twelve stamps found in London and the one at Silchester must belong to the beginning of the Roman occupation.

Oswald and Pryce, p. 51, etc. ; May, *Silchester*, p. 259 ; *C. I. L.* iii, 6010, 204 b ; xii, 5686, 807-8, 811-12 ; xiii, 10010, 1773, 1776, 2634.

59. (A) OF SEVERI. 18. Low level by the south turret, on west wall of fort.  
 (B) O SEVERI. 18. Very slight cone, small lettering. Site 1, low level.  
 (C) SEVERI M. 18. Slightly coned, bright glaze. Site 1, room 3. In a deposit assigned to 80-100, but which contained a few later fragments of pottery.  
 (D) SIIVII. 27. = SIIVIIIRIM fully. North-west of site 1 by north wall of fort.

The first three stamps belong to the La Graufesenque potter, who began working under Nero, but whose prolific output, especially to Britain, took place under the Flavians. Site-dating : on the Continent, Neuss, legionary camp (4), Wiesbaden, earlier stratum (common), Rottweil (5, Knorr, p. 66) ; in Britain, Newstead, Agricolan camp (Curle, p. 241), Wroxeter (6, 80-110/120 A.D., 1912-14, no. 112).

Stamp (D), if it comes from La Graufesenque, is likely to belong to the latest period of that pottery, viz. early second century. So far this peculiar lettering is only recorded on Drag. 31 and 33. A similar stamp at Wroxeter (1913, 112 B) was found in a pit with pottery mostly of first half of the second century. Possibly it belongs to a different potter of East Gaul or Gallia Belgica, as suggested by the site-distribution of other examples (e. g. Douai, Hautranges, Paris, Reims, Vieux-Virton, and Friedberg). Several Silchester stamps too (May, p. 260) seem corroborative.

Two other potters of the same name, both using the nominative case only, were at work at Rheinzabern and Westerndorf during the middle and second half of the second century.

Oswald and Pryce, p. 56 ; Lud. iii, 62-3, iv, 60 ; *C. I. L.* ii, 4970, 483 and 6257, 187 ; iii, 6010, 208 ; vii, 1336, 1037-40, 1047-8, 1051, 1053 ; xii, 5686, 829 ; xiii, 10010, 1800.

60. (A) [C SILV]I P. 18. Good glaze. Site 1, room 6. In a first-century deposit.

This La Graufesenque potter is also found under his full name C SILVI PATRICI. Six stamps on Drag. 18 have been noted, all in Britain, and three on Drag. 29.

One of the latter in the Guildhall Museum shows decoration which appears to be about the period of Vespasian (Bushe-Fox, *Wroxeter*, 1914, p. 50, no. 260). The stamp also occurs in the Steinkastell of Wiesbaden (83-122 A.D.).

Oswald and Pryce, p. 85; Ritterling, *Wiesbaden, O. R. L.*, xxxi, p. 109, 30; Walters, M. 748-9; *C. I. L.* vii, 1336, 1080 b, 1384; xiii, 10010, 1817-18.

61. (A) OF SILVINI. 27. Small lettering, stamped across a circular groove. North-west of site 1.

OF SILVINI. 27. Similar, small cup. North-west of site 1.

A plain potter of La Graufesenque, whose only pre-Flavian record seems to be two stamps found in Neuss, legionary camp. At Rottweil he is dated by Knorr (p. 66) the reign of Vespasian, but three stamps at Wroxeter (1912-13, 115 A, C, D) and another in the Bregenz Cellar Find place him in the period of Domitian-Trajan.

An East Gaulish Silvinus, possibly from Luxeuil, is assigned by Barthel (*O. R. L., Zugmantel*, p. 148) to the reigns of Hadrian and Pius (117-161 A.D.). The Wroxeter stamp (1912, 115 B), dated probably 110-130 A.D., would belong to this second potter.

*C. I. L.* ii, 4970, 491 and 6349, 39; vii, 1336, 1069, 1071, 1074; xii, 5686, 842; xiii, 10010, 1814.

62. (A) SOLLEMMNIS. 18. Thin. Site 1.

Fourteen stamps of this potter, chiefly on Drag. 18 or 18/31, were found by Forrer at Heiligenberg (p. 235). He is probably to be placed in the first half of the second century.

There were two other potters of this name: SOLLEMNI O, OF or M, who made Drag. 37 and 33 at Lezoux, Antonine (Déch. i, 301; Walters, M. 1743-4), and a Rheinzabern plain potter (Lud. iii, 63, iv, 61) found at Rottweil (Knorr, p. 66) and on the Limes (*Cannstatt, O. R. L.*, lix, pp. 58, 161; Osterburken, *C. I. L.* xiii, 10010, 1830 f.).

The double 1 only occurs in the Heiligenberg stamps (Forrer, pl. xvii, 64, 64<sup>a</sup>).

*C. I. L.* iii, 6010, 212 (Rheinzabern); xiii, 10010, 1830 and 10011, 271 (Lezoux).

63. (A) S·VRDILLV2· 18. Coned, in tabella ansata. Site 1, room 6. Top soil.

A little-known Gaulish potter. Similar stamp on a coned plate at Faimingen (*O. R. L.* xxxv, pp. 67, 119). In Britain it is

found at Wroxeter on Drag. 18/31 (1912, no. 119) and Colchester (*Mus. Report*, 1911, p. 11). Probably belongs to the first half of the second century.

*C. I. L.* xiii, 10010, 1861.

64. (A) OF VIRIT. 18. Slightly domed. Site 1, room 6.  
Top soil.

(B) OF VIRIL. 27. Good glaze, stamped across a circular groove. Site 1.

The British Museum contains two stamps of this potter, on Drag. 29 and 27. The former, coming from Torre Annunziata, will be dated before 79 A.D. Virillius is probably of South Gaulish origin.

*C. I. L.* xii, 5686, 938 (Geneva, Nîmes, Vienne). Not in xiii, 10010.

65. (A) OFVITA. 27. Large, good glaze. Site 1, room 3.  
In a deposit assigned to 80-100, but which contained some later fragments of pottery.

(B) OFVITA. 27. Large. Site 1, room 6. In a deposit mostly of the first century.

(C) OFVITĀ. 18. Nearly flat. Site 1, room 6. Top soil.

(D) OFVITAI. 18/31. Site 1.

(E) OFVITAL. 18. Thin plate, fine glaze. Site 1, room 6.  
In a deposit assigned to 80-120.

(F) OFVITALI. 18/31. Large, thick. Site 1, room 6.  
In a deposit assigned to 80-120.

See Decorated Stamps, no. 9 (A).

66. (A) Rosette of eight petals, diameter  $\frac{9}{16}$  in., stamped on a slightly concave base. Site 1, 9.

Rosettes vary from four to fifteen petals, those with eight being the commonest. They occur chiefly on Drag. shapes, 32, 32/40, 33, 46, and on Lud. Tb, Tc, Td. They have been found at Lezoux, Ittenweiler, and Rheinzabern, especially at the last-named, and last from about mid second century till mid third century. Site-dating: Pudding-pan Rock (140/150-190 A.D.), on Pan Rock forms 7 and 8 with rosettes of twelve petals (3); Niederbieber (190-260 A.D.) many rosette stamps, all rough and degenerate. The Richborough example, identical with one on Lud. Td from Wroxeter, must belong to the middle or second half of the second century. *Guildhall Mus. Cat.*, p. 394, nos. 98-9; Forrer, p. 216; Lud. ii, 92; iii, 81-2; iv, 72; May, *Silchester*, pl. LXXXI; Oelmann, *Niederbieber*, pl. ix; *Wroxeter*, 1912, p. 64,



fig. 15; Limes Reports, e. g. Faimingen, Feldberg, Kapersburg, Marienfels, Stockstadt, Zugmantel.

## UNCERTAIN, FRAGMENTARY AND ILLEGIBLE STAMPS

(Arranged by sites)

~~OR~~~~AB~~ VI. 27. Large. Outside west wall of fort.  
 ? OF  $\widehat{\text{ALBINI}}$ , La Grauf. 35-85 A.D.

~~W~~ ~~W~~  $\backslash$ . 27. Small, dullish glaze. Outside west wall of fort.

?? OF IVCVNDI, La Grauf. Flavian.

~~AA~~ I. 33. Large, slightly domed. West gate.

?  $\widehat{\text{MARI}}$ , South Gaulish. Cf. *C. I. L.* xiii, 10010, 1278 e, MARI (Orleans).

IF MV. ? 27. On slightly domed surface in concave base. West gate.

? OF MV. As on Drag. 20 Wiesbaden, *O. R. L.* xxxi, p. 108, 20 (83-122 A.D.), on 27 Guildhall Museum, *C. I. L.* xiii, 10010, 1392.

Cf. OF MVF on 33. Small, dullish brown-red glaze, York Museum.

$\vee$   $\Delta$  PI. 24/5 (Hofheim 6). Small. North-west of site 1, low level.

?  $\widehat{\text{VAPI}}$ , pre-Flavian.

Cf. VAP Sels, VAPIF La Grauf., VAPVS Weisenau, VAPVSO Hofheim (Claudian), and Wiesbaden (early stratum). *C. I. L.* xiii, 10010, 1971-2.

CO $\rho$ /. Lud. Sb., within rouletted ring. Site 1.

$\vee$  CUN/. 33. Dullish glaze. Site 1.

Possibly CRACVNA, Antonine at Newstead and Corbridge.

$\Delta$  INV $\epsilon$ . 31. No glaze on underside. Site 1.

? REGINVS, Rheinzabern, 120/5-150 A.D.

/INI/. ? 38. Large, thick, concave base. Site 1.

~~LLV~~/. 18/31. Smallish lettering. Four or five letters illegible at beginning. Site 1.

-OI/. 18. Bright glaze. Site 1.

PA/. 18/31. Good glaze. Site 1.

$\vee$  V/. 18. Large, thin plate, dull glaze. Site 1.

? SVLPICI, La Grauf., late first century.

•T $\Delta$  $\Delta$ . 18. Site 1.

ΛΑΙΙΙΙΙΜ. 33. Large, dullish brown glaze. Site 1.  
Probably Lezoux, second century.

ΛΜΙC. 33. Site 1.

Illegible. 27. Large, brownish-red glaze. Site 1.

/S.EN/+ 3 or 4 letters. 31. Thin; good, matt glaze. Site 1,  
room 6, top soil.


CELER + 2 indistinct letters. 24/25 (Hofheim 6), fine glaze,  
low foot-ring. Site 1, room 6. In a first-century  
deposit.

Probably a stamp of Celer, pre-Flavian potter of Montans,  
found at Sels and Hofheim (Ritterling, *Hofheim*, pp. 244, 249).

Illegible. 27. Site 1, room 6. In a first-century deposit.

ΛΑΑΡ. 27. Small, good glaze, early cup. Site 1, room 6.  
In a first-century deposit.

? AMAN or AMAND. South Gaulish, pre-Flavian. *C. I. L.* xiii,  
10010, 100; xii, 5686, 39.

OF RI. 27. Large. Site 1, room 6, in a deposit dated  
75-120.

Probably OF SEVERI. See plain stamps, no. 58.

Illegible. 27. Small. Site 1, room 6. Low level, first cen-  
tury.

ΜΙΙΥΡΑ. 31. High cone, brownish-red glaze, three-quarters of  
dish preserved. Site 1, room 8.

? MEND(A), but D uncertain.

Menda, if correct, is an East Gaulish potter of second century,  
probably from Lavoye (36 stamps at Reims). Two stamps in  
Britain, both on Drag. 33, G.P.O., London and York, on a cup  
with orange-red glaze. Lambert, *Arch.* lxvi, 240; *C. I. L.* xiii,  
10010, 1342 (b<sup>4</sup> almost identical).

/ΑΤΙΟF. 18. Thin plate, stamped within rouletted ring.  
Site 1.

ROGATI OF. Pre-Flavian (Sels, Hofheim, first camp) is  
possible. PATERATI OF (Antonine) seems too long.

Illegible. 33. Large, thin cup, fine glaze. Site 1.  
Part of a second impression remains.

CEP/. 32. Yellowish glaze. Site 1, 9.  
Probably CERALIS, Antonine potter of Rheinzabern.

CL. 18. Poor glaze. Site 1, 9.  
? PATERCLI (Domitian-Trajan).

- CAL/. 18. North-west of site 1.
- MARC/. 33. Small, thin cup. North-west of site 1, in filling of ditch.
- CC/. Lud. Tv (cf. Drag. 51), large lettering, orange-red glaze. North-west of site 1.  
Probably COCVSF, East Gaulish potter of second century.
- /CI·M. Large lettering on a flat plate. Underside has several well-moulded concentric circles. North-west of site 1, near north wall of fort.
- Illegible. 27. Very small, early cup. South of site 1.
- OFI-/. 27. Pit 2, 10 ft. down.
- IIIPIN. 24/25. Very small, early cup. Pit 10, bottom, a mixed deposit, but mostly of the late first century.  
? ALBINI, La Grauf., 35-85 A. D.
- O/. 18/31. Pit 13. First and early second century.
- \71. 18/31. Ditto.


## STAMP ON BELGIC WARE

- I. Illegible (about 6 letters), stamped on underside of base of a fine, thin, grey vase, probably globular. Site 1, top soil.

## STAMP ON LAMP


- I. EVC[ARPI]. Stamped on underside of base within three concentric circles. Tip from site 1.  
Site-dating: Neuss, first century A. D.  
Five of these stamps have been found in London (*Guildhall Mus. Cat.*, pp. 45-6, nos. 21-5). *C. I. L.* xiii, 10001, 122 (Neuss  $\eta$ ); xv, pt. i, 6421.


## STAMPS ON AMPHORAE

- I.  Stamped downwards on handle. =  
C. ANTONI QVIETI. Site 1,  
room 8.  
Cf. *C. I. L.* vii, 1331, 13; xii, 5683, 28; xiii, 10002, 104 (Lezoux, d<sup>1.2</sup>); xv, II, i, 2703 (Monte Testaccio).  
The stamp found at Newstead (pl. LII, 6, and p. 270) probably belongs to the Agricolan camp.

2. PCC. Stamped across at foot of handle. Pit 14, 20 ft. down.  
Claudian. Possibly a measure.


Cf. *C. I. L.* xiii, 10003, 114, PC1111 from Arentsburg, 115, XOP from Vechten, stamped on the neck.

3.  Stamped downwards on handle. Pit 13, 18 ft.—  
23 ft. down. First or early second century.  
Cf. *Wroxeter*, 1914, p. 57, fig. 3, 22 (undated).  
*C. I. L.* xii, 5683, 56; xiii, 10002, 153; xv, 11,  
i, 2763 (Monte Testaccio), 3419. See p. 97, no. 50.

4.  Stamped downwards on left side of handle.  
Pit 9. The finds in this pit were mostly of  
the first century.

Cf. GRAT *C. I. L.* xii, 5683, 120.  
GRAIVS E Ibid. xiii, 10002, 171.  
GRA Ibid. xv, 11, i, 2903 (Monte Testaccio).  
CRATI Ibid. xv, 11, i, 3464.


Gratus has also been found on mortaria stamps, e.g. at Balmuildy, Newstead, and Templeborough.

5. [III]  Stamped downwards on handle. =  
Trium Enniorum Juliorum and  
wreath. North-west of site 1.

In Britain: *Corbridge Report*, 1911, p. 59, 2; May, *Silchester*,  
p. 279, 13.

On the Limes: Cannstatt (*O. R. L.*, p. 68), Ems (*O. R. L.*,  
p. 35), Stockstadt (*O. R. L.*, p. 118; xx, 31), end of the first century.  
*C. I. L.* xii, 5683, 89; xiii, 10002, 200; xv, 11, i, 2816  
(Monte Testaccio).

A facsimile of the above stamp *C. I. L.* xv, 11, i, 2816 a (5 ex.),  
Or. ii, in infimo colle. Stamps found on north and east sides of  
Monte Testaccio are not later than Pius (138–161 A.D.) and 'at  
bottom of hill' probably somewhat earlier (*C. I. L.* xv, p. 492).

6.  Stamped downwards on left side of handle.  
South-east of site 1, top soil. = C. I. ( ).  
TAB( ) fully.

CIA.B found at Weissenburg (*O. R. L.* lxxii, Taf. v, 10 a) and  
there stated to be common in the Limes district. Probably second  
century. Other examples:

C·I·A	<i>Wroxeter</i> 1914, p. 58, 28.
GIA.B	<i>C. I. L.</i> xii, 5683, 127 c, Vienne.
C:I:A:	Ibid. xv, 11, i, 2917, Monte Testaccio.
G·I·A·B	Ibid. 2921 h                   "           "           7 ex.
G I A B	Ibid. 2921 i                   "           "           4 ex.

With additional names:

C · I · Æ · N̄C = C I ALB ANIC(ETI ?), *ibid.*, 2921 *k*  
 in Hortis Torlonia, 6 ex.  
 in Esquiliis, 1 ex.

C · I · Æ HEC = C I ALB HĒC( ), *ibid.*, 2921 *l*, Torlonia, 2 ex.  
 „ PAR = „ PĀR( ), „ 2921 *m*, „ 2 ex.  
 „ SĀ = „ SĀT(VRNI ?), „ 2991 *n*, „ 2 ex.

7. ΠΙΥΝ ΜΕΛΙΣΣΙ Stamped downwards in two lines on handle.  
 ETMELISSEI Poor stamp reconstructed from other known  
 examples. Room 9.

Cf. *Corbridge Report*, 1911, p. 59, 3 (4 ex.); *Silchester*, p. 280, 18-20; *Wroxeter*, 1912, p. 67, fig. 16, 7, and 1914, p. 57, fig. 3, 30.

*C. I. L.* vii, 1331, 59; xii, 59863, 154; xiii, 10002, 53, 296-7; xv, II, i, 2966-7 (Monte Testaccio), 3169.

In *C. I. L.* xiii, 296, and Zugmantel (*O. R. L.* viii, p. 170, 15) this stamp occurs with that of the farm F(undus) SCIMNIANVS on the other handle, showing that its provenance was Astigi in Baetica, South Spain (Oelmann, *Niederbieber*, p. 66).

8. Stamped downwards on handle. Pit 12.



First and early second century.

Cf. *C. I. L.* x, 8049, 11 (Pompeii); xiii, 10002, 32; xv, 3079 (Monte Testaccio).

9.  Stamped downwards on handle. Probably  
 = PORPAH or PORLAR. Site 1.

Cf. a similar uncertain stamp in Chester Museum.

POR PAH CF, *Wroxeter*, 1912, p. 65, 3, 'Early years of second century'.

PORPAH (3 ex.) and PORPAHSA, *C. I. L.* xv, II, i, 2647-8 (Rome).

PORPAH, POR·P·S·A, POR·P·S, *C. I. L.* xii, 5683, 228 (5 ex. Gall. Narb.).

POR LAH, *C. I. L.* xiii, 10002, 27 *b*; xv, II, i, 2661, Monte Testaccio, Sept. 1, viz. not later than Pius.

10. Stamped downwards on left side of handle.  
 Site 1.





Cf. SER·ROM, Torlonia, Rome, *C. I. L.* xv, II, i, 3183, and SER, *op. cit.*, Ste


Colombe and Monte Testaccio.

SER·B at Newstead (pl. LI, 9 and p. 270) probably belongs to the Agricolan camp.

## STAMPS ON MORTARIA (PELVES)


1.  With herring-bone border above and below.  
Hard light buff ware, white grit, some on flange. Site 1.  
See p. 102, no. 93.  
Cf. *Guildhall Mus. Cat.*, p. 102, 617 (read as CRACIVSF).


2.  Pale yellow buff ware, slightly pink core, white grit.  
West gate.  
Stamped on Wroxeter Mortaria types 10-14, dated to late first century A. D.  
Cf. May, *Silchester*, p. 276, 7, LITVGENI||IVC··IVLLI, and p. 278, 28 (fragment similar).  
Walters, M., 2781.  
*C. I. L.* xiii, 10006, 44, LITVGINOS, Vichy.

3.  Pinkish buff. Site 1, top soil.  
= MARINVS?  
On Wroxeter Mortaria types between 38 and 58, dated late first century or first half of second century A. D.


This name is well known on Romano-British sites, but in most of the stamps the letters are better formed.

Cf. Chester Museum, two stamps, one with addition of [L]VGVDV EECI, showing that Marinus worked at Lyons; *Guildhall Cat.*, p. 102, 624; *Newstead*, p. 266, 17 (80-110 A. D.); May, *Silchester*, p. 276, 10; *Templeborough*, p. 121, plate xxxviii, 7 a-b; Walters, M., 2783-5; *Wroxeter*, 1912, p. 67, fig. 16, 6 (80-110 A. D.).

4.  Light buff, white grit (some on flange). West gate.  
Probably Q VALERIVS  
SVRIANVS  
On Wroxeter Mortarium type 18, late first century A. D.  
No parallel found.

5.  Hard reddish buff clay. West gate.  
= Q VALERIVS  
VERANIVS  
See p. 102, no. 94.  
Cf. *Guildhall Mus. Cat.*, p. 102, 631 (read as Q VERIVS);

May, *Silchester*, p. 277, 19-20; Walters, M. 2812 (facsimile), 2813-16; *Wroxeter*, 1913, p. 45, fig. 17, 39 (probably on same type); *C. I. L.* vii, 1336, 63; xiii, 10006, 97.

6.  Remains of two lines, pinkish brown slip, on coarse greyer clay. Site 1, room 7.  
On a knobbed flange, not among Wroxeter Mortaria types. The nearest parallel is at Poltross Burn dated 120-180 A. D. (*Trans. Cumb. and West. A. and A. Soc.* xi, N.S., facing p. 452, plate IV, no. 3). Cf. V. EMIE, Northampton Museum.

7. A herring-bone pattern stamp. Site 1.

Cf. May, *Silchester*, p. 278, 23-5.

Miller, *Balmuildy*, plate XL, 1-3, where it is stated that similar second-century stamps occur at Ardoch, Bar Hill, Newstead, and Poltross Burn.

#### THE COARSE POTTERY

(Plates xx-xxx)

A vast quantity of coarse pottery, practically all in fragments, was collected during the excavations. The finds from the various sites, wells, pits, and deposits were, however, kept separate, and when washed and sorted it was often found possible to put together many of the fragments and to build up at any rate one side of some of the vessels, thus enabling accurate drawings to be made showing the complete form. In instances where it was impossible to obtain a complete side no attempt has been made to restore the missing portions in the drawings, unless the shape could be ascertained with some certainty from other examples, when a reconstruction has been indicated by dotted lines. The specimens chosen for illustration are those which either can be dated with some certainty by their association with other objects, throw some light on the history of the site, or are in themselves interesting examples. Types already well known and about which there is nothing new to be recorded have not been dealt with.

If no coins, Samian or other datable objects, had been found upon the site it would have been possible to secure from the coarse ware alone much accurate data concerning the occupation. Several of the vessels, such as nos. 1, 3, 21, 29, are of very pronounced Late-Celtic character and might well belong to the period immediately preceding the Roman occupation, although their association with datable Roman objects shows that this was not the case, thus affording valuable evidence for the continuance of some

of these purely pre-Roman types after the invasion of Claudius. There was only one piece of pottery found that could with certainty be said to have been deposited on the site in pre-Roman times, viz. a fragment of the upper part of a vessel of the Hengistbury A class illustrated on pl. x, 1-7 of that report, which can be assigned to the Hallstatt period. The whole period of the Roman occupation of this country is represented by the various types found, the flagons alone ranging from Claudian times to the fourth century, the earliest example probably being no. 66, while the latest are nos. 117-19 and 123. Among the finer continental wares were a few fragments of the first century green-glaze vessels and portions of the small delicately made cups as no. 59, while no. 89 is an exceptionally good example of the very thin-sided ware with a highly polished black surface. A few fragments of the best class mica-dusted ware were also met with, and there were many pieces of the red clay vessels with metallic surface made in the Rhine district in the second and third centuries. The proportion of Castor ware is small, but there were portions of several vessels decorated with the well-known hunting scenes, etc. in applied clay. The poppy-head variety, no. 54, and the carinated beakers, nos. 75-7, both types found in the Upchurch district, were present in considerable quantities and were commoner than on more northerly sites in this country. Some well-known types, found often on sites in the midlands and the north, were entirely wanting, such as the vessels having their sides covered with applied clay in regular or irregular ridges or lumps (*Wroxeter* 1913, fig. 18, 50-53) and the mugs with handles (*Wroxeter* 1912, fig. 18, 40).

As might be expected the late types were very numerous, especially the red-coated ware which is obviously a direct imitation of Samian, many of the forms being similar. Unlike the Samian, this ware was never made in moulds, but when decorated the patterns were either roulette notched or stamped with devices generally formed of rosettes, leaves, etc., as nos. 125, 126, and pl. xxx. Circular depressions (pl. xxx, no. 1) are also a not uncommon feature, and in some instances the decoration is carried out in paint or slip of a whitish colour (nos. 112, 113). These types of decoration are not confined to the red-coated wares, but are also found on contemporary vessels generally similar in form but of various colours and technique.

The Richborough types, nos. 107, 109-14, 127, can all be paralleled at the New Forest pottery at Ashley Rails, as can also many of the decorative motives. That the greater part of this ware found at Richborough came from the New Forest



potteries is, however, improbable, as some of the decorative motives are not common to both places, and the clay of many of the Richborough specimens is of an entirely different character from the Ashley Rails examples. Also the fact that the very hard pottery with a red-purple metallic surface, made in the New Forest in considerable quantities, is only represented at Richborough by two or three small fragments, suggests that there was little or no trade between the two places. This conclusion is largely borne out by Mr. Sumner's statement that the red-coated ware found at Silchester—a site much nearer to, and therefore more likely to have obtained pottery from, the New Forest—is not of the Ashley Rails fabric. Specimens of this ware found in a well at Mildenhall near Marlborough were all of one type of clay, but this also was not that of the Ashley Rails potteries, although the forms used were identical (*Wilts. Arch. Mag.* xli, p. 154).

The Roman kilns at Sandford, Oxon. (May, *Arch.*, vol. lxxii, p. 225) also produced ware of this class, and the following types found there, some of them wasters, correspond very closely to examples from Richborough, viz. Sandford, fig. 1, no. 6 to Richborough, type 104; fig. 1, nos. 7, 8 to types 109–12; fig. 1, nos. 10–12 to type 114; fig. 2, no. 14 to types 107, 115 and fig. 6, no. 29 to type 98. Here again, however, it would be dangerous to assert that any of the Richborough examples were actually made at Sandford.

There is still much to be learnt about these red-coated and other closely allied wares found in fair quantities on late sites in the south and midlands, but which become less common towards the north and west. The vessels from different sites show very little variation in type, but there are differences in clay and decoration, and it would seem that this ware was made in several localities, and was not solely distributed from any one particular centre. That many of the forms are direct copies of Samian shapes should indicate that there cannot have been any considerable interval in time between the cessation of imports of that ware and the beginning of the manufacture of the local imitations. There is not, however, sufficient evidence at present to enable a date to be fixed for the earliest examples, and it cannot even be established with certainty that this ware was being made during the latter part of the third century, although that some at any rate of the types, especially those exactly imitating Samian forms, must be at least as early as that date seems probable.<sup>1</sup> Mr. Sumner's coin-finds at Ashley Rails, i. e. one

<sup>1</sup> An example closely resembling Richborough type 107 was found at Castell Collen with a coin of Geta, 198–209 A.D., but as these do not appear to have been

Antoninus Pius, two of the Gallienus period *c.* 270 A.D., and two Constantine, point to an occupation in the late third and the first half of the fourth century, but whether this ware was being made there during the whole or only part of this period has not been decided.

At Huntcliffe, a site occupied in the second half of the fourth century, types, corresponding in form to the Richborough examples nos. 109-12, were met with (*J. R. S.*, vol. ii, fig. 40, no. 7). Examples of this ware were found at Segontium (*Y Cymmrodor*, vol. xxxiii), and the types from there, fig. 77, nos. 39, 40, corresponding to the Richborough types 109-12 were dated 350-370 A.D.; fig. 78, no. 52, assigned to mid or late fourth century, is similar to Richborough type 113, and fig. 78, no. 57, of Richborough type 104, was placed in the fourth century. There were also in the filling of the well at Mildenhall near Marlborough, mentioned above, several specimens of this ware, decorated either with stamped rosettes and demi-rosettes or patterns in white slip or roulette notching, strikingly similar to Richborough examples, and the forms also corresponded very closely to the Richborough types 107, 109-12, 113, 127, the commonest being 113. The coins from this well show that it was filled in about 375 A.D., thirty-seven of Valentinian I (364-375 A.D.) being found, but none of a later date (*Wilts. Arch. Mag.* xli, p. 153). That there was a large amount of this ware in use at Richborough in the fourth century is certain, nearly all the fragments found being in the top three feet, which, although a mixed deposit owing to the disturbed nature of the site, contained a large number of coins of that century, the majority belonging to its closing years. The following are the only datable deposits that contained specimens of this ware:—Pit 1, mid fourth century, in which were the red-coated examples 107, 109, 113 in association with other varieties, types 97, 102, 106, 116, 120, 121, 124, 131; pit 6, also mid fourth century, in which were types 103, 112, with other varieties, types 117, 128-30; pit 5, of fourth-century date, in which were types 98, 104, 111, with other varieties, types 105, 101; group I, a collection of pottery of fourth-century date found together near the north wall of site 1, containing type 126 of the red-coated ware with other varieties, types 100, 118, 119, 122, 123.

If the dating evidence from Richborough and the other sites enumerated above is summarized, it will be found that types 103, 104, 107, 109-14, 124-30, 133 can all be broadly assigned to the fourth century. Of these, types 107, 109-12, 113, 127 are known in a sealed deposit this evidence must be accepted with caution. *Arch. Camb.*, ser. 6, vol. xiv, p. 49, no. 14.

to occur as late as 375 A.D., and 103, 107, 109-12, 113, 124, 128-30 were in use in the middle of the fourth century. Although 114 is found at Richborough in fair quantities, its date, c. 275-350 A.D., at present can only be based on the Ashley Rails evidence, and it must also be remembered that if the red-coated ware was being made at that pottery in the late third century, types 107, 109, 113, 127 may be as early as that date.

It is doubtful whether there is any direct connexion between the British stamped ware and the continental, which has been dealt with by M. Déchelette and which he believed to be of a date later than the beginning of the fifth century A.D. (Déch., vol. ii, p. 327). The Marne ware, type 95, a few examples of which have been found at Richborough, is however imported, and although M. Déchelette assigned it to the fourth and fifth centuries (Déch., vol. ii, p. 325, pl. xi, 1, 2), he considered that it might even have been as early as the third century, but owned that he had no evidence for this. With the evidence now available, it is doubtful whether it was introduced into this country before the latter part of the fourth century.

Types 97-102, of which a large quantity were found of various clays and technique, some being red-coated, were also in use in the fourth century, but the date of their first introduction is uncertain.

PIT 14 (pls. xx, xxi)

1. Tall cordoned urn of typical Late-Celtic type. Base wanting but probably of similar form to either type 6 or 8 from Swarling (*Swarling Report*, pl. vii). Hard fumed grey clay with pasty slip. Pit 14. Claudian.

2. Narrow-necked jar decorated with burnished zones, girth-grooves and wavy scored lines. Hard fumed grey clay with smoothed surface. Pit 14. Claudian. This vessel was, however, found in the mouth of the pit and may be later.

Cf. Curle, *Newstead*, pl. XLVII, 38. 80-100 A.D.

3. Thick angle-sided cup with cordon on side and omphalos base. Hard sandy fumed clay with traces of black varnish on outside. Late-Celtic type. Pit 14. Claudian.

Cf. *Swarling Report*, pl. iv, fig. 2, from Deal, and pl. ix, 26, from Swarling; *Colch. Mus. Report*, 1919-20, pl. 1, from Wickham Bishops.

4. Narrow-necked vase or jar decorated on the shoulder with a zone of diagonal incised lines between two cordons or corruga-

tions. Slightly concave base. Hard fumed grey clay with black varnish. Pit 14. Claudian.

Cf. *J. R. S.*, vol. xiii, p. 120 and pl. xi, 13, from Margidunum, Claudian; May, *Silchester*, pl. lxxvi, 9, 10, Late-Celtic type.

5. Narrow-necked jar or vase. Two cordons at base of neck and decorated with two zones of incised lines separated by two girth-grooves. Slightly concave base. Hard fumed grey clay with black varnish. Pit 14. Claudian. Late-Celtic type. See no. 4.

6. Beaker with slight ledge at base of neck and girth-groove on bulge. Slightly concave base. Dark brown clay with traces of black varnish on exterior. Pit 14. Claudian. Cf. no. 8.

7. Tall slightly bulged beaker. Fumed grey clay with black varnish on outside. Pit 14. Claudian. (*Hofheim*, pl. xxxv, 88, 40-51 A.D.)

8. Beaker decorated with two girth-grooves. Dirty drab to fumed grey unwashed clay. Pit 14. Claudian. Cf. no. 6.

9. Plate with raised foot-ring. Hard fumed grey clay well polished inside and thinly varnished black. Pit 14. Claudian. (*Silchester*, p. 176, pl. lxxiv, 186; *Hofheim*, pl. xxxvi, 97 B. 40-91 A.D.) Cf. no. 10.

10. Plate with raised foot-ring. Hard fumed grey clay with darker surface. Pit 14. Claudian. Cf. no. 9.

11. Bi-conical bowl with level reeded rim, girth grooves on side. Hard sandy fumed grey clay, black varnished and burnished. Pit 14. Claudian.

Cf. *O. R. L.*, *Wiesbaden*, xxxiii, pl. xiii, 10.

12. Indented rough-cast beaker. Extremely hard brittle pale buff to nearly white clay coated with black to reddish brown slip inside and brown to mottled red outside. Pit 14. Claudian. See no. 55. Cf. *Wroxeter* 1913, fig. 18, no. 54—a slightly later variety.

13. Hand-made beaker with plain slightly curved lip and flat base. Unwashed dark brownish clay with grey clay slip. Pit 14. Claudian.

14. Bowl with almond-shaped overhanging rim, girth-grooves on neck and bulge. Conjectural restoration of base. Hard fumed light grey clay, upper part of bowl polished. Pit 14. Claudian.

15. Lid. Smooth buff clay. The clay slightly pinched in centre to provide a grip. Pit 14. Claudian.

Several of these were found in early deposits. They were probably used to cover the mouths of flagons or amphorae. (*Newstead*, pl. LI, 14.)

16. Bowl with slightly concave base. Thin hard fumed grey clay with darker unsmoothed surface. Pit 14. Claudian.

Cf. *Hofheim*, pl. xxxv, 87 B; pl. xxxvii, 114 B, 121; *May, Silchester*, pl. lxxvii, 5.

17. Bead-rim beaker decorated with a zone of vertical incised lines and two girth-grooves. Hard fumed grey clay. Pit 14. Claudian. For remarks on bead-rim bowls see *Hengistbury Head Report*, p. 47.

18. Bead-rim bowl with slightly concave base. Decorated below the lip with a row of small roughly oval impressions. Hard brittle smoky grey clay containing a large proportion of sand. Pit 14. Claudian. See nos. 17, 19.

19. Bowl or beaker decorated with a zone of incised lines below a girth-groove above which the surface is polished. Grey rough fumed clay thinly coated with a soapy slip. Pit 14. Claudian. Cf. no. 17 and *Arch.* lxvi, p. 247, fig. 14, no. 12, 50-80 A.D., from London.

20. Bowl with carinated side and girth-grooves under level rim. Hard sandy fumed grey clay. Pit 14. Claudian.

Cf. *Hofheim*, pl. xxxvii, 127; *O. R. L., Wiesbaden*, xxxi, pl. XIII, 27.

#### WELL 1 (pls. XXI-XXIII)

21. Bead-rim olla or beaker decorated with a horizontal striated band on the shoulder and furrowed with diagonal incised lines. Grey coarse clay smeared with smooth pasty clay inside. Late Celtic technique. Well 1, bottom. Mid first century. See nos. 17, 19.

22. Carinated bowl with rim recessed for a cover. Well 1, filling. Late first century.

Cf. *Arch.* lxvi, p. 249, fig. 15, no. 18, 50-80 A.D., from London.

23. Level rimmed carinated bowl. Hard fumed grey clay. Well 1, filling. Late first century. See no. 22.

24. Jar with two-ribbed loop handles and decorated with a scored wavy line on the neck. Hard brittle white clay. Well 1, near bottom. Mid or late first century.

Cf. *Hofheim*, pl. xxxv, 66 D. Vespasianic; *Wroxeter* 1913, type 48, 80-130 A. D.

25. Upper part of amphora with peaked handles. Pale buff clay with light brown to purplish inside slip. Well 1, bottom. Mid first century. (*Haltern*, 1912, types 66, 67, Augustan; Hölder, *Röm. Tongefässe*, 1907, pl. 1, 11, from Pompeii.)

26. Boldly bulged olla with recurved rim and concave base. Hard sandy fumed grey clay with thin black varnish outside. Well 1, bottom. Mid first century.

27. Olla or cooking pot with low cordons and a zone of oblique scored lines on neck and shoulder. Hard well-baked grey clay with uneven tool-marked surface. Well 1, bottom. Mid first century.

Cf. *Swarling Report*, pl. VIII, 20.

28. Beaker or small olla with out-bent level rim and two girth-grooves below. Hard thin light grey clay. Well 1, near bottom. Mid or late first century.

29. Large olla of hard well-baked clay, light grey with darker surface. The rim and shoulder have a varnished appearance. A ledge or offset at the base of the rim and a striated zone on the shoulder and bulge. Slightly concave base. Well 1, bottom. Mid first century. Late-Celtic type.

30. Incense bowl with hollow pedestal. Harsh sandy buff clay, smoke blackened inside and partly outside. Well 1, filling. Late first century.

31. Plate or dish with slight foot-ring, mouldings on inside and outside of rim and base. Light drab clay. Well 1, filling. Late first century.

32. Lid or cover. Hard grey fumed clay with darker coating. Well 1, bottom. Mid first century.

33. Flagon with four-ringed mouth and three-ribbed handle. Hard brittle pure white clay. Well 1, bottom. Mid first century.

Angular handle indicates early date, see *Hofheim*, type 54. Another flagon of similar type but of hard thin pale buff to reddish clay was found in association with this.

34. Neck of flagon with four-ringed mouth and three-ribbed handle. Hard thin white sandy clay. Well 1, near bottom. Mid or late first century.

Cf. *Wroxeter Report*, 1912, types 1 and 3, 80-130 A. D.; May, *Silchester*, pl. XLII, 118, late first century.

35. Neck of flagon with four-ringed mouth and three-ribbed handle. Hard dirty drab to buff clay. Well 1, near bottom. Mid or late first century. See no. 34.

36. Flagon with four-ringed mouth and two-ribbed handle. Pale buff hard clay. Well 1, near bottom. Mid or late first century.

37. Neck of flagon with moulded and undercut lip. Hard pale buff clay. Well 1, near bottom. Mid or late first century.

Cf. May, *Silchester*, pl. LXII, 113.

38. Flagon with moulded disc mouth and two-ribbed handle. Dirty white clay. Well 1, near bottom. Mid or late first century. Handle as *Hofheim*, p. 283, no. 10.

PIT 2 (pls. XXIII, XXIV)

39. Flagon with flanged mouth, three-ribbed handle and foot-ring. Hard light buff clay. Pit 2, near the bottom and may be mid first century as the form suggests. See p. 20.

Cf. May, *Silchester*, pl. LXII, 113.

40. Flagon with two three-ribbed handles. Hard fumed grey clay with darker surface. Pit 2. (*Wroxeter Report*, 1913, type 45, late first or early second century; *O. R. L., Wiesbaden*, xxxi, pl. XIII, 14, pl. xv, 61, first or early second century.)

Cf. *Hofheim*, type 57 c; *Niederbieber*, type 65.

41. Upper part of olla with vertical-sided undercut rim and moulded ledge at foot of neck. Thin hard fumed grey clay black varnished. Pit 2, near the bottom and may be mid first century. See p. 20.

42. Level-rimmed olla with concave base and a girth-groove on body. Hard brittle fumed grey clay. Pit 2, but near the bottom and may be mid first century. See p. 20.

Cf. May, *Silchester*, pl. LXXVII, 5; Curle, *Newstead*, pl. XLIX, B 2. 80-110 A. D.

43. Olla with oblique moulded rim, a girth-groove on the shoulder, slightly concave base. Good hard clay, brown outside, darker inside. Pit 2.

44. Upper part of incense bowl. Hard pale buff pipeclay with remains of soot on inside surface. Pit 2.

Cf. no. 30. (May, *Silchester*, pl. LXXI, 165; *Hofheim*, type 71.)

45. Upper part of cup, imitating Samian, form 27. Hard fumed grey clay polished and black varnished. Pit 2.

Another similar example was found to the north-west of site 1.

46. Dish or platter with angular rim. Hard sandy fumed grey clay with scored lattice pattern round the outside. Pit 2. Late first or early second century. (*Newstead*, p. 259, fig. 32, no. 2, Antonine.)

47. Olla with oblique rim and flat surface on inside of lip. Decorated on shoulder with a zone of oblique rows of small indentations. Hard flaky fumed grey clay with darker surface of smooth slip. Pit 2, near the bottom and may be mid first century. Cf. no. 48.

#### MISCELLANEOUS (pls. xxiv-xxx)

48. Olla decorated on the shoulder with a zone of oblique rows of small indentations. Hard brittle fumed grey clay with black varnish. Several of this type were found in first-century deposits. Examples can be seen in the Colchester Museum from that locality.

Cf. no. 47.

49. Small olla or beaker with two girth-grooves at the base of neck. Sandy light tile-red clay. Pit 13, filling. First or early second century.

Cf. *Wroxeter Report*, 1912, type 32, 90-120 A.D.

50. Upper part of amphora. Hard flaky light buff clay. Q. C. R. stamped on handle (p. 85). Pit 13. First or early second century. (*Newstead*, pl. LII, 1, 80-110 A.D.; Hall, *Caer Lugwy*, p. 49, pl. xviii, 160.)

51. Upper part of olla with out-curved beaded rim, an offset between neck and shoulder. Hard smooth thin clay fumed grey. Site 1, unstratified. Probably of early date.

52. Hand-made olla with recurved rim and the upper part of bulge decorated with horizontal striations. Hard sandy fumed grey clay burnt red in places. Pit 10. A mixed deposit with a large proportion of first-century fragments, to which period this vessel probably belongs.

These horizontal striations occur on pre-Roman pottery. See *Hengistbury Head*, pl. xxvi, 9-11, dated before 100 B.C., and *Swarling Report*, pl. ix, 22, first century B.C. A fair number of



fragments of this ware have been found at Richborough. It also occurs at Margidunum (*J. R. S.*, vol. xiii, pl. xi, 20) in the Claudian period; and at Alfoldean (*Sussex Arch. Coll.*, vol. lxxv, pl. iv, 22, p. 141).

53. Upper part of olla with out-bent and recessed rim for taking a lid. Hard gritted fumed grey to brown clay. Site 1, unstratified.

Cf. Oelmann, *Niederbieber*, pl. III, 89, 190-260 A.D. Ludowici, type U 2 and 4, with Antonine pottery.

54. 'Poppy head' beaker with cordon at base of neck and decorated with rectangular groups of parallel rows of small clay studs. Thin hard brownish-grey clay, black surface inside, grey outside. Pit 4. Antonine. A large number of this type were found, and they appear to belong to the second century, some being not far removed from the year 100 A.D. (Walters, M. 2644, fig. 272; *Wroxeter Report*, 1913, p. 50, pl. xv, 11, 13; May, *Silchester*, pl. lxx, 160; *Arch.* lxxi, p. 177, figs. 13, 92.)

55. Indented beaker of thin fine reddish clay coated with mica. Pit 11. First and second century. This example is of first-century type. See no. 12.

56. Jar with upright flanged mouth. Decorated with two girth-grooves, a wavy scored line and polished zone. Grey clay. Site 1, unstratified.

57. Hand-made olla with slightly out-bent lip and concave base. Mottled reddish-brown to black clay, soft and brittle. Site 1, unstratified.

Cf. May, *Silchester*, pl. lxxvii, 8.

58. Plate with quarter-round moulding and high foot-ring. Soft white pipeclay tinted to brown in places. Imitation of the Samian forms, *Hofheim*, types 3 and 4. Found in the lowest road metalling in front of site 1, and is probably mid first century.

59. Small 'rough cast' cup. Thin white clay with light brown slip. Lowest level, site 1, room 5. Mid first century. (*Wroxeter Report*, 1914, p. 63, type 73-4; *Haltern*, 1912, xxvii, 22; *Hofheim*, type 22 *Aa*, 40-51 A.D.)

60. Small cup or bowl with out-bent beaded lip and slight cordon on shoulder. Hard sandy-grey clay with darker surface. Site 1, in top soil. Has Late-Celtic characteristics and may be of early date although its find-spot suggests the late third or fourth century.

61. Upper part of olla with out-bent lip and broad flat cordon at base of neck. Hard light grey clay with grey to buff slip. Graffito LVIII scratched on shoulder after baking. Site 1, unstratified.

Cf. May, *Silchester*, pl. LXXVI, 10.

62. Small beaker with oblique rim and wide bulge. Thin smooth brownish clay. Site 1, unstratified. First-century type.

63. Part of small beaker with oblique rim. Decorated with girth-grooves and scored wavy lines. Hard grey clay with darker outside surface. Site 1, low level. First-century type. For practically similar example see *J. R. S.* xiii, p. 124 and pl. XI, 22. Claudian, from Margidunum.

Cf. *Wroxeter Report*, 1912, types 26, 27, 80-120 A.D.; *Arch. Ael.*, ser. iii, vol. viii, p. 172, pl. XII, 75, from Corbridge.

64. Upper part of olla with small oblique rim, sloping straight neck with two slight corrugations at its base, and a wide girth-groove below. Hard thin fumed grey clay, well polished outside. Pit 12, bottom. Probably first century.

65. Upper part of olla with frill under lip and four four-ribbed handles. Hard pale buff to cream coloured clay. Site 1, unstratified.

Cf. *Hofheim*, p. 315, Abb. 79, for frilled rim.

66. Neck of flagon with four-ribbed handle. Moulded and undercut lip. Site 1, low level. Early first-century type.

Cf. Loeschke, *Haltern*, type 47, Abb. 24.

67. Neck of flagon with three-ribbed handle. Strongly moulded and undercut lip. Bright hard red clay with buff slip. Site 1, unstratified. Mid first-century type.

Cf. *Hofheim*, p. 279, Abb. 62, no. 1, type 50.

68. Neck of flagon with three-ribbed handle. Strongly moulded slightly undercut rim. Hard pinkish clay with cream slip. Site 1, unstratified. First-century type.

Cf. no. 67; Curle, *Newstead*, pl. XLIX, B 2; May, *Silchester*, pl. LXII, no. 113.

69. Neck of flagon with four-ribbed handle. Heavily moulded lip. Hard light red clay with light buff slip. Site 1, unstratified. First-century type.

Cf. 67, 68, but poorer workmanship and later in date.

70. Flagon with four-ringed mouth and three-ribbed handle. Hollow base with foot-ring. Hard sandy thin light buff clay. Pit 13. First or early second century. (*Wroxeter Report*, 1912,

type 3, 80-130 A.D.; May, *Silchester*, pl. LXII, 118, end of first century; *Newstead*, p. 262, fig. 33, 1-3, 80-110 A.D.)

71. Flagon with two double-ribbed handles. Raised beaded base. Straight edged slightly undercut mouth. Hard light brown clay. Site 1, unstratified. Probably not earlier than the second century.

72. Small flagon with three mouldings on cup-shaped mouth and handle with two unequal ribs. Site 1, unstratified. Probably second or third century.

73. Angular-sided bowl, hand made. Unwashed brownish grey clay coated with pasty slip. Pit 11. First and second century. This example has Late-Celtic characteristics and is probably not far removed from the middle of the first century A.D. in date. (*Hengistbury Head Report*, pl. xxvi, 5, Pre-Roman.)

74. Carinated bowl with cordon and moulded foot-ring. Grey clay at core with reddened outer layer and black varnished surface. Late Celtic in character. Site 1, 6, in association with first-century pottery.

75. Carinated beaker with out-bent beaded rim. Hard brittle fumed grey clay with polished surface. Site 1, unstratified. A later development of *Hofheim*, type 113. See nos. 76, 77.

Cf. May, *Silchester*, pl. LXXII, 169, 171.

76. Carinated beaker with spreading rim and rising grooved base. Thin hard grey clay with silver-grey, glossy slip. Site 1, unstratified. See nos. 75, 77.

77. Angular-sided bowl or beaker with overhanging lip and slightly raised base. Fumed hard heavy and dense grey clay. Pit 11. First and second century. This example probably belongs to the first half of the second century. See nos. 75, 76.

78. Level rimmed round-sided bowl with upright neck. Hard thin sandy fumed grey clay. Pit 12. First and early second century.

79. Bowl with sloping reeded rim and wide girth-groove on side. Hard sandy dull grey fumed clay; first-century type. Site 1.

Cf. Ludowici, *Rheinzaubern*, type P 7, found with second-century pottery.

80. Bowl with undercut reeded rim and two girth-grooves on side. Slightly concave base. Hard sandy fumed clay with slightly darker varnish. Site 1, unstratified. First-century type.

Cf. *Newstead*, pl. XLVII, 37; *O.R.L.*, *Wiesbaden*, xxxi, pl. XIII, 27; *Arch. Ael.*, ser. iii, vol. viii, p. 170, pl. II, 5, from Corbridge.

81. Child's feeding bottle. Hard light buff clay. Site 1, top soil and probably late in date.

82. Hand-made olla with bead rim and concave base. Decorated with girth-grooves. Dark brown, with dirty brown slip outside, dark grey within. Site 1, low level. First century.

83. Flat plate with two girth-grooves on upright side. Hard light brown to red clay. Site 1, room 1, in association with pottery belonging to the first and early second century.

84. Plate or dish with wide-spreading side and heavily moulded lip. Light red clay well smoothed inside and on top of lip. Site 1, unstratified. (*Jour. Brit. Arch. Assoc.* xxii, p. 177, fig. 20, no. 2, Charlton.) Probably first century.

85. Dish or plate. Pale brown clay with grey core, surface dusted with mica. Site 1, room 1, in association with late first and early second-century pottery. (*Wroxeter Report*, 1912, fig. 17, 22, 80-110 A.D.)

86. Plate with curved side, beaded rim, and thin slightly concave base. Hard grey clay. Site 1, low level. First century.

87. Plate or saucer with slightly concave base. Bright reddish-buff clay well smoothed and baked. Site 1, room 1, in association with pottery of the second half of the first century. (*Hofheim*, pl. xxxiii, 44, Vespasian period.)

88. Open bowl, incurved rim, thick-sided and decorated with two girth-grooves. Clay hard sandy pale buff to light red at core. Site 1, unstratified. (Oelmann, *Niederbieber*, pl. III, 53 A, 190-260 A.D.)

89. Unusual bowl of exceptionally fine technique. Very thin hard fine grey clay with black highly polished surface.

The thin wall, carinated bulge, and black polish are characteristic of Belgic ware. Not found in a stratified deposit, but is certainly of first-century type.

90. Lid or cover with holes in top to let out steam, etc. Hard fumed grey clay. Site 1. Probably of early date. Cf. *Arch.* lxvi, p. 251, fig. 16, nos. 51, 52, 71-100 and 80-120 A.D. from London.

91. Lid or cover with flange. Hard brittle sandy brownish-grey clay with black surface. Site 1. Probably of early date. See no. 90.

92. Large lid or cover. Coarse fumed grey clay with black varnished surface. Site 1. Probably of early date.

93. Mortarium. Hard light buff clay with quartz particles, a few in rim. With stamp CRACILIS·F, p. 87. Site 1. Late first-century type (*Wroxeter Report*, types 14, 18, and Curle, *Newstead*, fig. 34, no. 1).

94. Mortarium. Hard reddish-buff clay with quartz grit. With stamp Q. VALERIVS·VERANIVS, p. 87. West gate. Late first-century type (*Wroxeter Report*, types 14, 18).

95. Bowl imitating Samian form 37. Hard pinkish-red clay with bright orange-red glaze. Decorated with five bands each apparently made with a roulette on which were nine small squares containing diagonal lines, lattice pattern, and crossed diagonal lines with dots and dashes. Found in association with pottery of the late fourth century (Walters, p. 79, M. 177, 178; Déchelette, ii, p. 325, 6; May, *Silchester*, pl. xxxiv, 44, pl. xxxviii, p. 99). See p. 92.

96. Bulbous beaker with screw knob inside base. The body decorated with rude S-shaped scrolls in white slip. Whitish pipeclay coated with black slip. Girth-grooves above and below decoration. Site 1. Found in association with pottery of the fourth century.

Cf. May, *Silchester*, pl. lII, 84, 89; *Wroxeter*, 1913, fig. 19, 69.

97. Flanged mortarium. Hard bright red clay with pale buff slip studded on inside with quartz particles. Pit 1. Mid fourth century. *J. R. S.* ii, fig. 40, no. 8, Huntcliffe, second half of fourth century (*Arch.* lxxi, p. 175, fig. 12, 87, fig. 14, 121). Cf. Oelmann, *Niederbieber*, p. 69, Abb. 53, 4; May, *Silchester*, pl. lXV, 135. See p. 92 and nos. 100-102.

98. Flanged mortarium. Pale drab core with reddish-buff slip. Quartz particles on inside surface. Pit 5. Fourth century.

See p. 92 and no. 99.

99. Flanged mortarium with particles of quartz on inner surface. Hard grey clay with smooth red surface. Site 1. Probably late third or fourth century. (*Wilts. Arch. Mag.* xli, p. 157, pl. 1, no. 8, Mildenhall, c. 375 A.D.; *Arch.* lxxii, p. 235, fig. 6, no. 29, Sandford.)

See no. 98.

100. Flanged mortarium. Hard pale red clay with light buff slip. Group 1. Fourth century.

See nos. 97, 101, 102.

101. Flanged mortarium. Tile-red clay with buff slip, quartz particles on inside. Pit 5. Fourth century.

See nos. 97, 100, 102.

102. Flanged mortarium. Hard grey to red clay with light buff slip. Pit 1. Mid fourth century.

See nos. 97-101.

103. Bowl with raised base and foot-ring. Nearly Ludowici shape Sh. Hard dark blue clay coated with red slip. Pit 6. Mid fourth century.

Cf. pp. 89-92 and no. 104, and *Arch.* lxxii, p. 228, fig. 1, 6.

104. Bowl or basin with beaded rim. Imitation of Samian form, Lud. Sh. Hard pale reddish clay with pinkish-red slip. Pit 5. Fourth century. (Wheeler, *Segontium*, fig. 78, no. 57, fourth century.)

See no. 103 and pp. 89-92.

105. Thick-sided bowl. Hard grey clay. Pit 5. Fourth century.

106. Dish with slightly concave base. Hard rough grey to black clay with black coating. Pit 1. Mid fourth century. Two other similar from this pit. (Cf. *Roman Pottery Site at Sloden and Black Heath Meadow*, pl. II, 16, IV, 9; *Arch.* lxxi, p. 180, fig. 15, 152, Hambleton.)

107. Straight-sided mortarium. Hard red clay, pinkish-red slip, studded inside with quartz particles. Pit 1. Mid fourth century. (*Wils. Arch. Mag.* xli, p. 157, pl. 1, no. 2, Mildenhall, c. 375 A. D.; *Ashley Rails*, pl. X A, 20-2; *Arch.* lxxii, p. 229, fig. 2, 14; May, *Silchester*, pl. LIV, 95; *Wroxeter Report*, 1912, p. 80, 242.) See pp. 89-92.

108. Bowl imitating Samian, form 81. Pale grey clay with smooth brown slip. Site 1. Probably late third or fourth century.

109. Flanged bowl, imitating Samian form 38, with oval folded flange. Dark grey clay with bright red slip. Pit 1. Mid fourth century. (*Wils. Arch. Mag.* xli, p. 157, pl. 1, no. 1, Mildenhall, c. 375 A. D.; Wheeler, *Segontium*, fig. 77, nos. 39, 40, 350-370 A. D.; *Arch.* lxxii, p. 228, fig. 1, 7, 8, Sandford; May, *Silchester*, pl. LIV, 94.)

Cf. *Ashley Rails*, pl. VII, 7-10. See pp. 89-92.

110. Flanged bowl imitating Samian, form 38. Bright red clay with grey core coated with deep red smooth slip. Site 1. Probably late third or fourth century.

See no. 109.

111. Bowl with oval folded-in flange. Light grey to red clay with dull red smooth polished surface. Pit 5. Fourth century.

See nos. 109-10.

112. Bowl with folded-in flange; imitation of Samian 38, decorated with a pattern in white paint. Blue clay coated with bright red slip almost a glaze. Pit 6. Mid fourth century. (*Ashley Rails*, pl. VIII, 8, for similar decoration.)

See nos. 109-11.

113. Small bowl or cup with carinated side and decorated with a pattern in white paint. Good brick-red clay with dark red slip inside, pale buff outside. Pit 1. Mid fourth century. This type is also found undecorated, and with roulette-notched and stamped patterns. (*Ashley Rails*, pls. iv, v, vi; May, *Silchester*, pl. LVI, 111; Wheeler, *Segontium*, fig. 78, no. 52, mid or late fourth century; *Wilt. Arch. Mag.* xli, p. 157, pl. 1, no. 3, Mildenhall, c. 375 A.D.) See pp. 89-92.

114. Part of lip of open bowl. Red clay with pink slip. Site 1. Probably late third or fourth century. (*Ashley Rails*, pl. VII, 1-4, pl. VIII, 8.) Cf. *Arch.* lxxii, p. 228, fig. 1, nos. 10-12. See pp. 89-92.

115. Rim of mortarium, diameter 12 inches, imitating Samian, form 45. Smooth hard brownish-red clay with similar coloured slip. Site 1. Probably late third or fourth century. See no. 107.

116. Upper part of bowl with two girth-grooves on side. Pale grey clay with darker surface. Pit 1. Mid fourth century.

117. Upper part of flagon with moulded lip and two-ribbed handle. Sandy cream coloured clay. Pit 6. Mid fourth century. Cf. May, *Silchester*, p. 129, pl. LVI, 104. Late fourth century.

118. One-handled flagon. Hard brownish-red clay with darker brown slip. Group 1. Fourth century. Handle joined to lip is a fourth-century feature.

Cf. *Ashley Rails*, pl. ix, nos. 5, 6, 9.

119. Two-handled flagon. Hard dark brown clay with smooth brown surface. Ornamented with four roulette-notched girth-grooves above and below bulge. Group 1. Fourth century.

Cf. Oelmann, *Niederbieber*, Abb. 27, 23 A.

120. Conical-necked beaker with cordon at base of neck and roulette hatching on bulge. Hard red clay with dark brownish-red slip. Pit 1. Mid fourth century.

Cf. May, *Silchester*, pl. LIV, 91.

121. Flanged bowl with oblique straight side. Hard grey clay with black varnish on surface of rim and half-way down the inside. Pit 1. Mid fourth century. Two others similar.

Cf. *Arch.* lxxi, p. 180, fig. 15, 146, Hambleden; May, *Silchester*, pl. LXVI, 201; *Arch. Ael.*, ser. iii, vol. viii, p. 172, pl. XII, 71, 72,

Corbridge; *Trans. Cumb. & Westm. Arch. & Ant. Soc.*, N.S. xi, p. 454, pl. v, 18, 19, Poltross Burn, 270-330 A.D.; *Ashley Rails*, pl. xii, 10.

122. Straight-sided flanged bowl. Hard rough grey to black clay, with black slip. Group 1. Fourth century. (*Sloden and Black Heath Meadow*, pl. iv, 19, pl. ix, 21.)

123. Two-handled flagon. Hard brown clay, grey at core with brown slip. Group 1. Fourth century.

Cf. Oelmann, *Niederbieber*, Abb. 27, 2 c, 2 k, and Hölder, *Formen Röm. Tongefässe*, pl. xiii, 8, Regensburg.

124. Cup, imitating Samian form 33. Light yellowish clay with smoothed yellowish-brown surface. Pit 1. Mid fourth century. Cf. *Arch.* lxxii, p. 228, fig. 1, no. 2. See pp. 89-92.

125. Bowl decorated below rim and on side with zones of roulette hatching. Pinkish clay with red slip. Site 1. Fourth century. (May, *Silchester*, p. 128, pl. lvi, 100.)

Cf. no. 126 and pp. 89-92.

126. Bowl decorated with stamped rosette and leaf patterns, and with notched or roulette bands. Hard red clay with dark red slip smoothed and polished. Group 1. Fourth century.

For stamped wares cf. May, *Silchester*, pl. lvi, 99, 100; *Ashley Rails*, p. 18.

See pp. 89-92.

127. Small bowl with raised foot-ring. Light red well-washed clay with traces of deep-red slip. Site 1. Probably late third or fourth century. (*Wilt. Arch. Mag.* xli, p. 157, pl. 1, no. 4, Mildenhall, c. 375 A.D.; *Ashley Rails*, p. 22, pl. iv, 3; May, *Silchester*, pl. lvi, 99, 100.)

See pp. 89-92.

128. One-handled mug. Hard light red clay coated with fine brown slip on outside and upper part of inside. Pit 6. Mid fourth century.

See pp. 89-92.

129. One-handled mug. Hard smooth dull brown clay coated with nearly black slip outside and on upper part of inside. Pit 6. Mid fourth century.

See pp. 89-92.

130. Bowl with one two-ribbed handle. Brown to black clay coated with smooth brown slip and decorated with stamped rosettes and demi-rosettes between vertical rows of small square incisions. Pit 6. Mid fourth century. See references to no. 126 and pp. 89-92.



131. Small flagon. Yellowish-brown clay with black slip.  
Pit 1. Mid fourth century.

Cf. Oelmann, *Niederbieber*, p. 59, Abb. 37, 1.

132. Upright-sided bowl decorated with a pattern of vertical and diagonal rows of square indentations. Pale pinkish-buff clay coated with cream-coloured slip. Site 1. Probably fourth century.

133. Carinated bowl decorated with impressed rosettes and demi-rosettes. Dirty grey clay coated with darker slip. Site 1. Probably fourth century.

See references to no. 126 and pp. 89-92.

134. (pl. xxx) Rhenish ware vase somewhat similar to the Samian form 52. Pinkish drab clay with metallic glaze. Decoration *en barbotine* consisting of conventional corn stalks divided by upright fronds between two bands of conical dots. A girth-groove below. Third century. Site 1.

Cf. Ludowici, iii, p. 272, v, Mc and h; May, *Silchester*, pl. xxxiv, 45.

#### COINS

The following catalogue has been prepared by Mr. A. G. K. Hayter. Mr. G. C. Brooke and Mr. H. Mattingly of the British Museum have very kindly identified several worn specimens, the former being responsible for the Gaulish and post-Roman coins, the latter for the Republican denarii. A large number of corroded third brasses was successfully treated with zinc and caustic soda by Mr. E. Jervoise. In the final compilation of the list Mr. G. C. F. Hayter rendered considerable assistance.

#### SUMMARY

	Æ	B	Æ
GAULISH . . . . .			1
ROMAN			
Republic . . . . .	6		
Augustus . . . . .			1
Agrippa . . . . .			1
Claudius I . . . . .			13
Antonia . . . . .			1
Nero . . . . .			6
Vespasian . . . . .	2		9
Vespasian or Titus . . . . .			1
Domitian . . . . .	1		9

	Æ	B	Æ
Nerva . . . . .			3
Trajan . . . . .	I		12
Hadrian . . . . .	3		5
Sabina . . . . .	I		I
Sabina and Hadrian . . . . .			I
Antoninus Pius . . . . .	2		4
Faustina I . . . . .			2
Marcus Aurelius . . . . .			I
Faustina II . . . . .	I		3
Commodus . . . . .	I		I
Uncertain attribution, second century . . . . .			I
Caracalla . . . . .	I		
Julia Domna . . . . .	I		
Trebonianus Gallus . . . . .		I	
Gallienus . . . . .		2	23
Salonina . . . . .		2	
Valerian II . . . . .		I	
Postumus . . . . .		I	I
Victorinus . . . . .			2I
Claudius II Gothicus . . . . .			67
Quintillus . . . . .			3
Tetricus I . . . . .			75
Tetricus II . . . . .			28
Aurelian . . . . .			I
Tacitus . . . . .			I
Numerianus . . . . .			I
Carausius . . . . .			6I
Allectus . . . . .			13
Radiate Crowns, 3 Æ., uncertain attribution . . . . .		4	144
Diocletian . . . . .			2
Maximianus Hercules . . . . .			3
Galerius . . . . .			I
Severus II . . . . .			I
Folles, 2 Æ., uncertain attribution . . . . .			2
Constantine I . . . . .			22
Constantinopolis . . . . .			58
Urbs Roma . . . . .			51
Hybrids . . . . .			5
Pop. Romanus . . . . .			3
Helena . . . . .			12
Theodora . . . . .			8
Crispus . . . . .			3

	R	B	Æ
Delmatus . . . . .			1
Constantine II . . . . .			24
Constantius II . . . . .	2		38
Constans . . . . .			56
Constantius II or Constans . . . . .			89
House of Constantine, uncertain attribution . . . . .			94
Magnentius . . . . .			11
Decentius . . . . .			1
Magnentius or Decentius . . . . .			6
Julian . . . . .	2		
Constantius II, Constans or Julian . . . . .			5
Jovian . . . . .	1		
Valentinian I . . . . .			40
Valens . . . . .			47
Gratian . . . . .			37
House of Valentinian I, uncertain attribution . . . . .			46
Magnus Maximus . . . . .			23
Flavius Victor . . . . .			11
Magnus Maximus or Flavius Victor . . . . .			5
House of Theodosius			
SALVS REIPVBLICAE . . . . .			388
Theodosius I . . . . .		36	
Valentinian II . . . . .		27	
Arcadius . . . . .		30	
Honorius . . . . .		21	
<i>Obv.</i> illegible . . . . .		274	
VICTORIA AVGGG, One Victory . . . . .			760
Theodosius I . . . . .		74	
Valentinian II . . . . .		65	
Arcadius . . . . .		144	
Honorius . . . . .		26	
<i>Obv.</i> illegible . . . . .		451	
VICTORIA AVGGG, Two Victories . . . . .			23
Theodosius I . . . . .		7	
Valentinian II . . . . .		6	
<i>Obv.</i> illegible . . . . .		10	
Other types : . . . . .			51
	R.	Æ.	
Theodosius I . . . . .	1	9	
Valentinian II . . . . .		6	
Arcadius . . . . .	2	15	

			Æ	
Honorius . . . . .	2	5		
<i>Obv.</i> or <i>Rev.</i> illegible	4	16		
Eugenius . . . . .				4
Total identified 2491 =		34	11	2446
Unidentified :				
Denarius . . . . .				1
Siliquae . . . . .				3
Antoniniani . . . . .				2
Dupondius . . . . .				1
Asses . . . . .				16
3 Æ. . . . .				76
3 Æ. Q. (minimi) . . . . .				543
Total unidentified 642 =		4	2	636
Total		3133.		

In this catalogue are included, not only those coins found in the excavations formally undertaken by the Society of Antiquaries in the autumns of 1922 and 1923, but also those from the West Gate (spring 1922) and surface finds of several previous years.

Of the first and second century very few are even fairly well preserved. Over a fifth of the total consists of totally illegible coins. In fact, the general average condition is poor throughout, that of the third brass radiate crowns (260-297 A.D.) being the worst. Many of these latter show signs of burning, especially those of Carausius. The large number representing this British emperor, sixty-one, is reasonable, seeing that Rutupiae may well have been used as his naval base.

The following table groups the legible coins under their respective periods, the Gaulish copper and Republican denarii being omitted :

Periods.	Coins.	Percentage of Total.
First century, 11-98 A.D.	47	1.9
Second century, 98-190 "	40	1.6
Third century, 193-259 "	6	0.2
260-306 "	455	18.3
Fourth century, 306-364 "	492	19.8
364-383 "	170	6.9
383-398 "	1274	51.3
Total	2484	

If the illegible coins are included, the following proportions are also obtained :

Periods.	Coins.	Percentage of Total.
11-259 A. D., 249 years	113	3.5
260-398 A. D., 139 years	3013	96.5
Total	3126	

From the above tables it will be seen that the proportion of coins before Gallienus became sole emperor is unusually small, and notably so in the first half of the third century even allowing for the fact that coins are then comparatively scarce. It is clear that the occupation, until then slight, must have suddenly increased during the second half of the third century. The first twenty-four years of the Constantine period produced only fifteen coins, but from 330 A.D. onwards the abundance of numismatic finds implies an intense occupation which culminates in the latest or Theodosian period.

The most striking feature of the Collection is the quantity of *minimi* (3 *Æ.* Q.) belonging to this period. Coins of Valentinian II, Theodosius I and his two sons are by no means uncommon in Britain and have been found in small numbers on more than eighty different sites (see R. G. Collingwood in *J. R. S.* xii, pp. 92-8). But the masses of them now being recovered at Richborough are elsewhere unparalleled. They total 1265 and may be profitably compared with the hoard from Hawara analysed by Mr. J. G. Milne (*J. R. S.* x, pp. 171-84). His remarks on the degradation of the coinage at this period and the masses of local imitations are equally applicable to the Richborough finds.

Rutupiae, from its geographical position, was evidently one of the final ports of evacuation for the Romans, and consequently these coins are the best evidence of the *terminus ad quem* of the Roman military occupation hitherto obtained. Though the Hawara hoard contains many more types than those noted below as falling within the same period, none is later than Arcadius (d. 408) and, in the opinion of Mr. Milne, 'there is no strong ground for considering the barbarous imitations as other than virtually contemporary with the imperial issues with which they circulated and which they imitated'.

Mr. Milne dates his hoard at 400-10 A.D. At Richborough the latest copper coins can all have been issued before the death of Theodosius I, in 395. The dating of the *siliquae* is uncertain,

though possibly no. 2440 of Honorius is as late as 398. The general conclusion is that there is as yet no archaeological evidence that the Roman official occupation lasted beyond the usually assigned date, viz. the end of the first decade of the fifth century.<sup>1</sup>

1148 of these Theodosian *minimi* can be assigned to two types, VICTORIA AVGGG with one Victory, and SALVS REIPVBLICAE. Both have been found with the obverses of all four emperors, Valentinian II, Theodosius I, Arcadius, and Honorius. In the first-named type 144 are assigned to Arcadius and only 26 to Honorius. Evidently this type appeared some years before the accession of Honorius, and must refer, as Dr. Craster has pointed out (*Corbridge Report* for 1911, 103), to the overthrow of Magnus Maximus, in 388. But the issue can hardly have continued after the death of Theodosius I in 395, both because of the comparatively small number with the head of Honorius and because there would no longer be three Augusti (VICTORIA AVGGG). 388-95 is therefore provisionally assigned to this type.

SALVS REIPVBLICAE is so much more equally distributed amongst the four obverses that its issue must have been of shorter duration and later date. The twenty-seven coins of Valentinian II show that, in spite of its absence with his name from the British Museum and Corbridge, Cohen and Banduri are justified and its issue must have begun before the death of Valentinian II in 392. Here, as in the previous type, Honorius completed the number of the three Augusti after 392. 390-95 is suggested for this type.

A third type, VICTORIA AVGGG with two Victories, is represented by only twenty-three coins, and was probably limited to Rome and Eastern mints. Rome issued it from five offices, labelled P S T Q E. At Richborough it has only been found with the heads of Valentinian II and Theodosius I, though Mr. Milne has one of Arcadius. This type may consequently have ceased before Honorius' accession, and can probably be dated 388-92.

No coins of any rarity have been noted, though specimens of Trebonianus Gallus, Numerianus, Delmatius, and Jovian are uncommon on British sites.

The Republican denarius (no. 5) of Scaurus and Hypsaeus is

<sup>1</sup> One silver coin of Constantine III (Roach Smith, *Rich., Recul. & Lymne*, 151, and pl. vi, no. 16) and two copper presumably struck during Constantine III's reign by Carausius (*Num. Chron.* iv, xv, 505, *Antiq. Journ.* vi, p. 312), and actually the latest coins ever found at Richborough, are confirmatory. Elsewhere in Britain only two later coins are known to the writer, viz. an aureus of Valentinian III (424-455 A.D.), stated to have been found at Barrington, Cambs. (Collingwood, *op. cit.*, p. 98), and a minimus of Honoria, his sister, *Rev. SALVS REIPVBLICAE* (mid fifth century), recently sent up to the British Museum from Caerwent by Dr. R. E. M. Wheeler.

interesting as representing the submission of King Aretas, in 52 B.C. This is the earliest Roman denarius on which a contemporary event is alluded to (Hill, *Handbook of Greek and Roman Coins*, 190).

Local imitations include one of Claudius I (*Rev.* Minerva, no. 22), of which several have been found at Wroxeter and elsewhere (see *Wroxeter Report*, 1914, 70), one of Antonia (no. 23), and a cast sestertius of Antoninus Pius (no. 82). The last still has its jagged edge adhering to it. Though no Roman mints are known in Britain before Carausius, Mr. Mattingly thinks this suggests the possibility of an irregular one at Richborough. In this connexion, the British Museum has recently received from Chester, where Professor R. Newstead was excavating in the Deanery Field, two denarii (one plated) of Severus. These are peculiar both in portrait and inscription, and might also be explained as having been issued from a local mint.

## Gaulish

### COPPER

1. *Obv.* Female head l.  
*Rev.* Quadruped (boar?) l.  
Size: 3 Æ. Q., but much heavier and ill-shapen. First century B.C.

## Roman

### REPUBLIC

#### R. Denarii

*Man. Acilius Glabrio*, triumvir (c. 50 B.C.)

2. *Obv.* Head of Salus r. Behind head, SALVTIS.  
*Rev.* Valetudo standing l., holding serpent in r. hand and resting l. arm on column; downwards on r. side, M ACILIVS, upwards on l. side, III VIR VALETV.  
Grueber, ii, pp. 496-7, 3943-6.  
*L. and C. Memmius* (Lucii filii Galeria?) 87 B.C.
3. *Obv.* Head of Saturn, laureate and bearded, r. Behind head, harpa and EX S C. Below chin, letter A.  
*Rev.* Venus nude in biga r., with horses walking, holds reins with both hands and sceptre in l.; above, cupid with wreath. In exergue, L · C · MEMIES  
L · F · GAL.  
Grueber, i, pp. 307-8, 2421-39.

*C. Norbanus* (c. 85 B.C.)

4. *Obv.* Head of Venus r., diademed and wearing earring and necklace. Below, C. NORBANVS.  
*Rev.* Fasces between ears of corn and caduceus on r.  
 Grueber, i, p. 347, 2770 ff.

*M. Aemilius Scaurus* and *P. Plautius Hypsaesus*, aediles (58 B.C.)

5. *Obv.* Aretas, king of Nabataeans, kneeling r., holds in r. hand olive branch and with l. camel, r., by bridle. Above, M SCAVR [AED CVR]; at side EX S C. In exergue [REX ARETAS].  
*Rev.* Jupiter in galloping quadriga l., hurling thunderbolt with r. hand. In exergue [P HYPSEVS AED CVR] C HYPSE [COS PREIVER CAPTV].  
 Grueber, i, pp. 483-4, 3876-82. See G. F. Hill, *Handbook of Greek and Roman Coins*, pl. XII, 5, and p. 190.

*C. Julius Caesar* (died 44 B.C.)

6. *Obv.* Elephant r. crushing a serpent. In exergue, CAESAR (obliterated).  
*Rev.* Simpulum, sprinkler, axe, and flamen's helmet.  
 Cohen 49.  $\mathcal{R}$ . (*Denarius*) 50 B.C.

## SECOND TRIUMVIRATE (43-31 B.C.)

*Marcus Antonius. Legionary Coin*

7. *Obv.* [ANT · AVG · III · V]IR · R · P · C. Praetorian galley, r.  
*Rev.* LEG . . . Military eagle between two standards.  
 $\mathcal{R}$ . (*Denarius*, debased) much worn. 31 B.C.

## EMPIRE

*Augustus* (30 B.C.-14 A.D.)

8. *Obv.* TI CAESAR AVGVST F IMPERAT V or VII. Head of Tiberius, laureate, r.  
*Rev.* Altar of Lugdunum, flanked by two columns, each surmounted by a Victory facing inwards and holding out a wreath. In exergue, ROM ET AVG.  
 Cohen 33, 38. Mattingly and Sydenham, p. 91, 368, 371.  
 2  $\mathcal{A}$ . (*As*) 11-14 A.D.



*M. Vipsanius Agrippa* (d. 12 B.C.)

9. *Obv.* [M · A]GRIPPA · L · F · COS III. Head l., wearing corona rostrata.  
*Rev.* Neptune standing l. with dolphin and trident. In field, S C.  
 Cohen 3. Mattingly and Sydenham, p. 108, Tiberius, 32.  
 2 Æ. (*As*) c. 23–32 A.D.

*Claudius I* (41–54 A.D.)

*Obv.* in all cases where legible:

TI CLAVDIVS CAESAR AVG P M TR P IMP P P.  
 1 Æ. *Sestertii*. Heads, laureate, r.

10. *Rev.* SPES AVGVSTA. Spes advancing l. with flower in r. hand, l. catching up dress. In exergue, S C.  
 Cohen 85. Mattingly and Sydenham, p. 129, 64.
11. *Rev.* Obliterated (corroded).  
 2 Æ. *Dupondius* and *Asses*. Heads, bare, l.
12. *Rev.* CERES AVGVSTA. Ceres veiled seated l., holding torch and ears of corn. In exergue, S C.  
 Cohen 1. M. and S., p. 129, 67. (*Dupondius*)
13. *Rev.* LIB[ER]TAS AVG[VSTA]. Libertas standing r., with cap in r. hand and l. extended. In field, S C.  
 Cohen 47. M. and S., p. 130, 69. (*As*, corroded)  
 41 A.D. (Cohen).
- 14–21. *Rev.* Minerva advancing r., hurling javelin and holding shield. In field, S C.  
 Cohen 84. M. and S., p. 129, 66. *Asses*, three much corroded. 41 A.D. (Cohen).
22. One similar, barbarous. See *Wroxeter*, 1914, p. 70.

*Antonia*, mother of Claudius I (Augusta, 37–9 A.D.)

23. *Obv.* ANTONIA AVGVSTA. Bust draped r., with hair *en queue*.  
*Rev.* [TI CLAVDIVS CAESAR AVG P M] TR P IMP. Claudius, veiled, standing l., holding simpulum in r. hand.  
 In field, S C. 2 Æ. (*As*)  
 Local imitation of commemorative coin issued by Claudius I.  
 Cf. Cohen 6. M. and S., Claudius I, p. 132, 82.

*Nero* (54-68 A.D.)

24. *Obv.* [NERO CL]AVD CAESAR AVG GE[R P M TR P IMP P P].  
Head, laureate, r.  
*Rev.* Obliterated. 1 Æ. (*Sestertius*) Burnt. 64-6 A.D.
- 25-6. *Obv.* NERO CLAVD CAESAR AVG GERMANICVS. Head,  
bare, r.  
*Rev.* PONTIF MAX TR POT IMP P P. Nero, laureate, r.,  
in female attire, singing and accompanying himself  
on lyre. In field S C.  
Cohen 247. M. and S., p. 170, 361. 2 Æ. (*As*) 64-6  
A.D.
27. As preceding, but *Obv.* Head, bare, l.  
Cohen 246. M. and S., p. 170, 364. 2 Æ. (*As*) Same  
date.
28. *Obv.* IMP NERO CAESAR AVG P MAX TR P P P. Head,  
bare, l.  
*Rev.* Victory to l., rising in the air and holding in l. hand  
a shield inscribed S·P·Q·R· In field, S C.  
Cohen 303. M. and S., 329. 2 Æ. (*As*) 66-8 A.D.
29. *Obv.* IMP NERO CAESAR AVG P M . . . Head, bare, l.  
*Rev.* Illegible. Draped female figure moving l. (?Victory).  
In field, S C. 3 Æ. (*As*) Same date.

*Vespasian* (69-79 A.D.)*Denarii* : heads, laureate, r.

30. *Obv.* [IMP CAESAR VE]SPASIANVS AVG.  
*Rev.* COS ITER [TR POT]. Fortuna seated l., with branch  
and caduceus.  
Cohen, 1st ed., vii, p. 57, 8. Corbridge Report for 1909,  
*Arch. Ael.*, 3 S., vii, p. 257. 70 A.D.
31. *Obv.* IMP CAESAR VESPASIANVS AVG. (Inscribed out-  
wards)  
*Rev.* As preceding.  
Cf. *Wroxeter*, 1914, p. 76, 571-2. (Plated) 70 A.D.

*Sestertius* : head, laureate, r.

32. *Obv.* Illegible. *Rev.* Obliterated.

*Dupondii* : heads, radiate, r.

33. *Obv.* [IMP] CAESAR VESPASIAN AV[G COS III].  
*Rev.* PAX [AVG]. Pax standing l. at altar, holding patera  
 and caduceus (with olive branch). In field, S C.  
 Cohen 300. 71 A.D.
34. *Obv.* . . . PA . . .                      *Rev.* Obliterated.

*Asses* : heads, laureate, r.

35. *Obv.* IMP CAES VESPASIAN AVG COS III.  
*Rev.* FIDES PVBLICA. Fides l., with patera and cornu-  
 copiae. In field, S C.  
 Cohen 165. 71 A.D.
36. *Obv.* IMP CAES VESPASIAN AVG COS VIII P P.  
*Rev.* As preceding.  
 Cohen 166. 77-8 A.D.
37. *Obv.* [IMP CAESAR] VESPASIAN AVG COS III.  
*Rev.* SECVRITAS [AVGVSTI]. Securitas seated r., sup-  
 porting head on r. hand and holding sceptre in l.  
 (in front, altar). In exergue, S C.  
 Cohen 506. 71 A.D.
38. *Obv.* IMP]CAES VESPASIAN A[VG . . . .].  
*Rev.* Eagle on globe, head r., wings outspread. In  
 field, S C.  
 Cohen 480-1. 71-3 A.D.
39. *Obv.* [IMP CAESA]R VESPASIAN [AVG . . . ].  
*Rev.* [. . . ] AVG. Draped figure standing l. In  
 field, S C.
40. *Obv.* Illegible.  
*Rev.* Altar. In exergue, PROVIDEN. In field, S C.

*Vespasian or Titus* (69-81 A.D.)

41. *Obv.* Head, radiate, r.  
*Rev.* Female figure (Victory ?) standing. In field, S C.  
 2 Æ. (*Dupondius*) Cupped.

*Domitian* (81-96 A.D.)

*Denarius* : head, laureate, r.

42. *Obv.* CAESAR DIVI F DOMITIANVS COS VII (inscribed  
 outwards).  
*Rev.* PRINCEPS IVVENTVTIS. Plumed helmet on throne.  
 Cohen 399. 80 A.D.

*Dupondii*: heads, radiate, r.

43. *Obv.* IMP CAES DOMIT AVG GERM COS XII CENS PER P P.  
*Rev.* [AN]NON[A] AVG. Annona seated l., holding ears of corn; in front of her, a child standing. In exergue, S C.  
 Cohen 14. 86 A. D.
44. *Obv.* IMP C[AES . . .  
*Rev.* . . . AV]GVSTI. Figure standing l., with spear or sceptre. In field, S C.

*Asses*: heads, laureate, r.

45. *Obv.* [IMP CAES DOMIT] AVG GERM COS XII CENS PER P P.  
*Rev.* FORTVNAE AVGVSTI. Fortuna standing l., with rudder and cornucopiae. In field, S C.  
 Cohen 122. 86 A. D.
46. *Obv.* Same as preceding, but COS XIII.  
*Rev.* Same as preceding.  
 Cohen 125. 87 A. D.
47. *Obv.* Same as 45.  
*Rev.* MONETA AVGVSTI. Moneta standing l., with scales and cornucopiae. In field, S C.  
 Cohen 327. 86 A. D.
48. *Obv.* IMP CAES DOMITIAN AVG GERM COS XI.  
*Rev.* SALVTI AVGVSTI. Altar; in the upper panels ∴, in the two lower, a ring hanging from lion's muzzle. In field, S C.  
 Cohen 417. 85 A. D.
49. *Obv.* CAESAR AVG F DOMITIANVS COS V.  
*Rev.* Spes moving l., holding flower and catching up dress. In field, S C.  
 Cohen 454. 76 A. D.
50. *Obv.* [. . . ]DOM[IT . . . . PE]R P P.  
*Rev.* Illegible. Figure standing l.
51. *Obv.* [. . . .]DOMIT [. . . . . . . .]  
*Rev.* Obliterated.

*Nerva* (96–8 A.D.)

52. *Obv.* [IMP NERVA CAES AVG PM TR P COS III P P.]  
Head, laureate, r.  
*Rev.* [VEHICVLATIONE ITALIAE REMISSA. In exergue,  
S C.] Two mules, facing in opposite directions,  
feeding. Other details lost.  
Cohen 143. 1 Æ. (*Sestertius*) Worn. Jan.–Sept. 97 A.D.
53. *Obv.* IMP NERVA CAES [AVG] P M TR P II COS III P P.  
Head, radiate, r.  
*Rev.* [ ] AVGVST. Aequitas or Fortuna standing l.,  
with cornucopiae in l. hand.  
Cohen 9 or 62. 2 Æ. (*Dupondius*) Sept.–Dec. 97 A.D.
54. *Obv.* IMP NERVA CAES . . . . Head, radiate, r.  
*Rev.* Obliterated. 2 Æ. (*Dupondius*)

*Trajan* (98–117 A.D.)*Denarius* : head, laureate, r.

55. *Obv.* IMP CAES NER TRAIAN OPTIM AVG GER[M DAC].  
*Rev.* [PARTHICO P M TR P COS VI P P S P Q R]. Fortuna  
seated l., holding rudder and cornucopiae. In  
exergue, FORT RED.  
Cohen 150. 116–17 A.D.

*Sestertii* : heads, laureate, r.

56. *Obv.* IMP CAES [NER]VAE [TRAIANO AVG] GER DAC [P M]  
TR P COS V P P.  
*Rev.* S P Q R OP[TIMO PRINCIPI]. Fortuna standing l.,  
holding rudder and cornucopiae. In field, S C.  
Cohen 477. 104–11 A.D.
57. *Obv.* As preceding.  
*Rev.* [S P Q R OPTIMO PRINCIPI]. Octastyle temple. In  
central intercolumniation, female statue (Pax?)  
standing; in pediment, central figure, male, seated  
facing, with sceptre in r. hand; on either side,  
a recumbent statue; above pediment, other statues  
standing.  
Cohen 552. 104–11 A.D.

*Dupondii* : heads, radiate, r.

58. *Obv.* [IMP CAES NERVA T]R[AI]AN AVG [GERM P M].  
*Rev.* Illegible. Corroded and broken.

59. *Obv.* IMP CAE[S NER ] TRAIANO OPTIM[ AVG GER  
DAC PARTHICO].  
*Rev.* [P M TR] POT XX COS VI P P. Within an oak  
wreath, S C.  
Cf. Cohen 286-7. 116 A.D.

*Asses* : heads, laureate, r.

60. *Obv.* IMP CAES NERVA TRAIAN [AVG GERM P M].  
*Rev.* TR POT COS II P P. Victory moving l., bearing  
shield (inscribed S P Q R). In field, S C.  
Cohen 640. 98-9 A.D.
61. *Obv.* IMP CAES NERVA TRAIAN AVG GER DAC . . .  
*Rev.* Illegible. Figure standing r. In field, S C. 102-  
17 A.D.
62. *Obv.* [IMP CAES NERVA TRAI]AN AVG G[ER . . .  
*Rev.* Obliterated.
63. *Obv.* IMP CAES NERVA TRAIAN AVG . . .  
*Rev.* Obliterated.
64. *Obv.* . . . . TRAI]N A[VG . . .  
*Rev.* Illegible. Draped female figure seated r.
65. *Obv.* . . . . TRAI[AN . . . .  
*Rev.* Illegible. Figure standing l. In field, S C.
66. *Obv.* Illegible.  
*Rev.* Illegible. Victory flying r., holding wreath. In  
field, S C.
67. *Obv.* Illegible.  
*Rev.* Illegible. Draped female standing l., (?) child at  
feet.

*Hadrian* (117-38 A.D.)

*Denarii*

68. *Obv.* HADRIANVS AVGVSTVS [P P ?] Head, laureate, r.  
*Rev.* [COS III]. Abundantia seated l., modius at her  
feet.  
Cohen 379 or 380. Plated. 127 A.D.
69. *Obv.* [IMP CAES] TRAIAN [HA]DRIA[NVS A]VG. Bust,  
laureate and draped, r.  
*Rev.* P[M T]R P C[OS II]. Fortuna seated l., with rudder  
and cornucopiae. In exergue, FORT RED.  
Cohen 745. 118 A.D.

70. *Obv.* HADRIANVS [AVG] COS III P P. Head, laureate, r.  
*Rev.* SPES [P R]. Spes advancing l., holding flower in  
 r. hand and catching up dress with l.  
 Cohen 1411, 1413. 138 A.D.

*Sestertii*: Busts, laureate and draped, r.

71. *Obv.* [IMP CAES]AR TRAIAN H[ADRIANVS AVG].  
*Rev.* Illegible. Draped female figure standing l., with sceptre  
 in l. hand. 117-24 A.D.
72. *Obv. and Rev.* Illegible and corroded.

*Asses*

73. *Obv.* HADRIANVS AVGVSTVS P P. Head, laureate, r.  
*Rev.* COS III. Standing figure. In field, S C. 119-38  
 A.D.
74. *Obv.* IM[P CAES]AR [TRAIAN HADRIANVS AVG]. Head,  
 laureate, r.  
*Rev.* Illegible. Draped female figure standing l. In field,  
 S C. (Burnt)
75. *Obv.* [HAD]RIANVS AVG COS III P P. Bust, laureate and  
 draped, r.  
*Rev.* Illegible. Draped female figure standing l., with cor-  
 nucopiae. In field, S C. (Angular, pared)

*Sabina*, wife of Hadrian (128-36 A.D.)

76. *Obv.* SABINA AVGVSTA. Bust, diademed and draped, r.,  
 hair dressed on nape of neck.  
*Rev.* IVNONI REGINAE. Juno, veiled, standing l., and  
 holding patera and sceptre.  
 Cohen 43. *Æ.* (*Denarius*) 128-9 A.D.
77. *Obv.* [SABINA AVGV]STA HADRIANI AVG P P. Bust r.,  
 as preceding.  
*Rev.* VESTA. Vesta seated l. with palladium and sceptre.  
 In exergue, S C.  
 Cohen 82. 1 *Æ.* (*Sestertius*) 133 A.D.

*Sabina and Hadrian*

78. *Obv.* [SABIN]A [HADRIANI] AVG P P. Bust of Sabina,  
 diademed, r., with high head-dress.  
*Rev.* [HADRIA]NVS AVGVSTVS. Head of Hadrian, lau-  
 reate, r.  
 Not in Cohen. 2 *Æ.* (*As*) 128-36 A.D.

*Antoninus Pius* (138–61 A.D.)*Denarii* : heads, laureate, r.

79. *Obv.* ANTONINVS AVG PIVS P P.  
*Rev.* COS IIII. Thunderbolt on throne.  
 Cohen 345. 145–8 A.D.
80. *Obv.* ANTONINVS AVG PIVS P P [TR P . . .].  
*Rev.* COS IIII. Annona standing l., with ears of corn and  
 modius ; to right, a vessel.  
 Cf. Cohen 286–93. 148–56 A.D.

*Sestertii* : heads, laureate, r.

81. *Obv.* ANTONINVS AVG PIVS P P TR P COS III.  
*Rev.* IMPERATOR II. Victory standing l., holding a trophy  
 in either hand. In field, S C.  
 Cohen 434. 139 A.D.
82. *Obv.* ANTONINVS AVG PIVS P P TR P COS III.  
*Rev.* APOLLINI AVGVSTO. Apollo standing, facing l., with  
 patera and lyre. In field, S C.  
 Coin cast locally. Weight : 444.6 gr.  
 Cohen 62. Date, if original, would be 140–3 A.D.
83. *Obv.* [A]NTO[NI]NVS [AV]G [PIVS P P TR P . . .]. Head,  
 radiate, r.  
*Rev.* [PIETATI AVG COS . . .] Pietas standing between  
 two children (and holding two in her arms).  
 Cohen 625 or 627. 2 Æ. (*Dupondius*)
84. *Obv.* ANTONINVS AVG PIVS P [P TR P . . .]. Head,  
 laureate, r.  
*Rev.* Illegible. Sacrificial instruments. 2 Æ. (*As*)

*Faustina Senior* (d. 141 A.D.)

85. *Obv.* DIVA AVGVSTA FAVSTINA. Bust, veiled and  
 draped, r.  
*Rev.* AETER[NITAS]. Aeternitas, diademed, standing l., with  
 globe and sceptre. In field, S C.  
 Cohen 38. 2 Æ.
86. *Obv.* [DIVA FAVSTINA]. Bust, without veil, draped r.  
*Rev.* [AETER[NITAS]]. Type as preceding. In field, S C.  
 Not in Cohen. 2 Æ.



*Marcus Aurelius* (161–80 A.D.)

87. *Obv.* [IMP CAES M A]VREL ANTONINVS AVG P M. Head, laureate, r.  
*Rev.* CONCORD AVGVSTOR TR P XVI. M. Aurelius l., L. Verus r., holding a roll, standing, facing each other, wearing toga and joining hands. In field, S C ; in exergue, COS III.  
 Cohen 54. 1 Æ. (*Sestertius*) 162 A.D.

*Faustina II* (141–75 A.D.)

88. *Obv.* FAVSTINA AVGVSTA. Bust, draped, r.  
*Rev.* IVNO. Juno, veiled, standing l., with sceptre and patera ; peacock at feet.  
 Cohen 120. R. (*Denarius*) 161–75 A.D.
89. *Obv.* FAVSTINA AVGVSTA. Bust, draped, r.  
*Rev.* [VENVS] VICTRIX. Venus standing l., holding a Victory, and resting l. hand on shield supported by helmet. In field, S C.  
 Cohen 283. 1 Æ. (*Sestertius*) 161–75 A.D.
90. *Obv.* [DIVA F]AV[STINA PIA]. Bust, draped, r.  
*Rev.* AET[ERNITAS]. Aeternitas, veiled, seated l., holding sceptre and globe, on which stands a phoenix. In exergue, S C.  
 Cohen 8. 1 Æ. (*Sestertius*) 175 A.D.
91. *Obv.* FAVSTINA AVG PII AVG FIL. Bust, draped, r.  
*Rev.* FELICITAS. Felicitas standing l., holding caduceus and placing l. hand on hip. In field, S C.  
 Cohen 108. 2 Æ. (*As*) 141–61 A.D.

*Commodus* (180–92 A.D.)

92. *Obv.* M · COMM · ANT · P · FEL · AVG · BRIT · P · P. Head, laureate, r.  
*Rev.* TEMP FELIC P M TR P XV COS VI. Two cornucopiae filled with fruit ; between them, a winged caduceus.  
 Cohen 719. R. (*Denarius*, plated) 190 A.D.
93. *Obv.* M COMMODYVS ANTONINVS AVG PIVS. Youthful head, laureate, r.  
*Rev.* TR P VIII IMP VI COS IV P P SC. Victory advancing l., holding trophy in both hands.  
 Cohen 899. 1 Æ. (*Sestertius*, squarish) 183 A.D.

*Uncertain Attribution.* Second Century A.D.

94. *Obv.* Obliterated.  
*Rev.* Spes standing l., holding flower in r. hand and catching up dress with l. In field, S C. 2 Æ. Much corroded.

*Caracalla* (Caesar 196, Joint Emperor 198, Sole Emperor 212-17 A.D.)

95. *Obv.* M AVR ANTONINVS CAES. Youthful bust, draped, r.  
*Rev.* SPEI PERPETVAE. Spes advancing l. with flower in r. hand, l. catching up dress.  
 Cohen 594. Æ. (*Denarius*) plated. 196-7 A.D.

*Julia Domna*, wife of Septimius Severus (193-217 A.D.)

96. *Obv.* IVLIA AVGVSTA. Bust, draped, r.  
*Rev.* VENVS VICTRIX. Venus standing l., leaning on column and holding helmet and palm branch; shield at her feet.  
 Cohen 215. Æ. (*Denarius*) plated.

*Trebonianus Gallus* (251-3 A.D.)

97. *Obv.* IMP C C VIB TREB GALLVS P F AVG. Bust radiate and cuirassed r.  
*Rev.* AEQUITAS AVG. Aequitas standing l., with scales and cornucopiae.  
 Cohen 7. B. (*Antoninianus*)

*Gallienus* (sole emperor, 260-8 A.D.)

*Obv.* except where otherwise stated, GALLIENVS AVG.  
 Head, radiate, r.

- 98-9. *Rev.* ABVNDANTIA AVG. Abundantia standing r., pouring forth contents of cornucopiae.

Mint marks, B| (2) Rome.

Cohen 5. 3 Æ. (Possibly *Antoninianus* originally)

100. *Rev.* ANN[ONA AVG]. Annona standing l., holding ears of corn and cornucopiae.

Mint mark, |Q Rome.

Cohen 56. 3 Æ. (Small)

101. *Rev.* [AP]OLLINI CONS AVG. Centaur moving r., shooting with bow.

Mint mark, H Rome.

Cohen 72. 3 Æ.

102. *Rev.* DIANAE CONS AVG. Antelope moving r.  
Mint mark, XI Rome.  
Cohen 162. 3 Æ.
- 103-4. *Rev.* DIANAE CONS AVG. Gazelle moving l.  
Mint mark, XII Rome.  
Mint mark lost.  
Cohen 165. 3 Æ.
105. *Obv.* IMP GALLIENVS AVG. Head, radiate, r.  
*Rev.* FORTVNA RED. Fortuna standing l., with rudder and  
cornucopiae.  
Cohen 265. 3 Æ.
106. *Rev.* [FO]RTVNA REDV[X]. Type as preceding.  
Cohen 269. 3 Æ.
107. *Rev.* IOVI CONSERVAT. Jupiter, nude, standing l., with  
thunderbolt and vertical sceptre.  
Mint mark, |N Rome.  
Cohen 361. 3 Æ.
- 108-10. *Rev.* IOVI PROPVGNAT. Jupiter striding l., with  
thunderbolt uplifted in r. hand and pallium floating  
from l. hand.  
Mint marks, XI| (2), |XI Rome.  
Cohen 382. 3 Æ.
111. *Obv.* GALLIENVS AVG. Bust, radiate and cuirassed, l.  
*Rev.* IOVI VLTORI. Jupiter, advancing l., head r., with  
thunderbolt uplifted in r. hand and pallium float-  
ing from l. hand.  
Mint mark, S|  
Cohen 403. 3 Æ.
112. *Rev.* LAETITIA AVG. Laetitia standing l., with wreath  
and anchor.  
Mint mark, V| Rome.  
Cohen 423. 3 Æ.
113. *Rev.* [LEG III ITAL VI] P VI F. Stork standing r.  
Cohen 487 or 490. B. *Antoninianus*, fragment much cor-  
roded.
114. *Rev.* LIBERO P. CONS AVG. Panther passant l.  
Cohen 586. 3 Æ.

115. *Rev.* LIBERT AVG. Libertas standing l., with cap and transverse sceptre.  
Mint mark, |XI Rome.  
Variant of Cohen 596. 3 Æ. (Small)
- 116-19. *Rev.* MARTI PACIFERO. Mars, helmeted, standing l., with olive branch and vertical spear; shield on ground below l. arm.  
Mint marks, A| (2), H| (2), Rome.  
Cohen 617. 3 Æ.
120. *Rev.* PROVID AVG. Providentia standing l., staff in r. hand pointed downwards, cornucopiae in l.  
Cohen 869. 3 Æ. (Small)
- 121-2. *Rev.* Obliterated. 3 Æ. (Small)

*Cornelia Salonina* (wife of Gallienus)

123. *Obv.* COR SALONINA AVG. Bust, draped, on crescent, r.  
*Rev.* FECVNDITAS AVG. Fecunditas standing l., giving her hand to a child and holding cornucopiae.  
Mint mark, |Δ Rome.  
Cohen 40. B. *Antoninianus*.
124. *Obv.* SALONINA AVG. Bust, draped, on crescent, r.  
*Rev.* PVDICITIA. Pudicitia seated l., drawing veil over face with r. hand and holding transverse sceptre with l.  
Cohen 94. B. *Antoninianus*.

*Valerian II* (Caesar 253-9 A. D., son of Gallienus)

125. *Obv.* DIVO CAES VALERIANO. Head, radiate, r.  
*Rev.* CONSECRATIO. Altar aflame, with wreath.  
Cohen, Saloninus 12, 13. B. *Antoninianus*.  
Posthumous coin, struck by Gallienus, 259 A. D.

*Postumus* (258-67 A. D.)

126. *Obv.* IMP POST[VMVS A]VG. Bust, radiate and draped, r.  
*Rev.* CONCORD EQVIT. Concordia standing l., with patera and rudder resting on globe; r. foot on ship's prow.  
Mint mark, S Lyons (Webb).  
Cohen 19. B. *Antoninianus*.

127. *Obv.* IMP C POSTVMVS P F AVG. Bust, radiate and draped, r.  
*Rev.* ORIENS AVG. Sol, radiate, striding l., r. hand raised, l. holding whip.  
 Cohen 213. 3 Æ.

*Victorinus* (265-7 A. D.)

128. *Obv.* in all cases: IMP C VICTORINVS P F AVG. Bust, radiate and draped, r. 3 Æ.  
*Rev.* FIDES MILITVM. Fides standing l., with standard in either hand.  
 Cohen 37.
- 129-32. *Rev.* INVICTVS. Sol, radiate, striding l., r. hand raised, l. holding whip.  
 Mint marks, \*| (4).  
 Cohen 49.
- 133-7. *Rev.* PAX AVG. Peace standing l., with olive branch and transverse sceptre.  
 Mint mark, V|\* possibly Vienne (Webb).  
 Cohen 79.
138. *Rev.* PROVIDENTIA AVG. Providentia standing l., pointing with wand to globe at feet and holding cornucopiae.  
 Cohen 101.
139. *Rev.* SALVS AVG. Salus, standing l., holding vertical sceptre and feeding serpent rising from altar.  
 Cohen 118.
140. *Rev.* VICTORIA AVG. Victory advancing l., with wreath and palm branch.  
 Cohen 126. 3 Æ. (Large)
- 141-3. *Rev.* VIRTVS AVG. Virtus, helmeted, standing r., holding spear and resting on shield.  
 Cohen 131.
144. *Rev.* Illegible. Figure standing l., with outstretched hand.  
 3 Æ. (? Reduced *Antoninianus*)
- 145-7. *Rev.* Obliterated.
148. *Rev.* Illegible. Sol or Emperor (?), radiate, standing l., r. hand extended, l. holding sceptre (?).  
 Barbarous imitation of INVICTVS type.  
 3 Æ. (Ovoid)

*Claudius II Gothicus* (268–70 A. D.)

*Obv.*, unless otherwise stated, where legible : IMP C (or IMP)  
CLAVDIVS AVG. Head or draped bust, radiate, r.

3 Æ.

149. *Obv.* IMP C CLAVDIVS P F AVG. Bust, radiate and draped, r.

*Rev.* [AN]NONA AVG. Abundantia, standing l., with ear of corn and cornucopiae, placing foot on prow of ship.

Cf. Cohen 23.

150. *Obv.* Normal, but with v behind neck.

*Rev.* AEQVITAS AVG. Æquitas standing l., with scales and cornucopiae.

Mint mark,    |    Rome.

Cohen 6.

151. *Obv.* Illegible, without v.

*Rev.* As above. No mint mark.

Cohen 6. (Corroded)

152. *Rev.* AQVIT[A]S AVG (*sic*). As above.

Cf. Cohen 6.

153–4. *Rev.* FELICITAS AVG. Felicitas standing l., with caduceus and cornucopiae.

Mint mark,    |    B (1), Rome.

One mint mark illegible or wanting.

Cohen 79.

155–6. *Rev.* FIDES EXERCI. Fides standing l., with standard in either hand, that in l. slanting.

Cohen 87.

157. *Rev.* FIDES MILITVM. Fides standing l., with standard in r. hand, and spear in l.

Mint mark,    |    E Rome.

Cohen 92.

158–60. *Rev.* IOVI VICTORI. Jupiter standing l., with thunderbolt and sceptre.

Mint mark,    |    N (1), Rome.

Two mint marks illegible or wanting.

Cohen 129–31.

161. *Rev.* LIBERT AVG. Libertas standing l., with cap and sceptre.

Cohen 151, 152.

162. *Obv.* Bust, radiate and cuirassed, r.  
*Rev.* MARS VLTOR. Mars advancing r., with spear and trophy.  
 Cohen 154.
163. *Rev.* PAX AVGVSTI. Pax standing l., with olive branch and transverse sceptre.  
 Cohen 204.
164. *Rev.* PAX AVG. Pax standing l., with olive branch and vertical sceptre.  
 Mint mark,  $\frac{|}{P}$  Ticinum (Webb).  
 Cohen 201.
165. *Rev.* [SA]LVS AVG. Salus standing l. at altar (feeding serpent?) and holding vertical sceptre.  
 Cohen 265.
166. *Rev.* SECVRIT [AVG]. Securitas standing l., leaning on pillar and holding sceptre or caduceus.  
 Cohen 268, 269.
167. *Rev.* VIRTVS AVG. Virtus (or Mars), helmeted, standing l., with palm branch and vertical spear; shield at feet.  
 Mint mark,  $\frac{\text{e}|}{}$  Rome (Webb).  
 Cohen 313, 314.
168. *Rev.* [VBERITAS or VBERTAS AVG.] Uberitas standing l. with purse or bunch of grapes and cornucopiae.  
 Cohen 286 or 287.
169. *Obv.* CLAVD/. Back of radiate crown to forehead; overstruck with VB...VG. Lower part of figure of Uberitas.  
*Rev.* VBERIT/. Left side of Uberitas, r. hand holding purse; overstruck with /LAVDIVS/. Top of radiate crown.  
 Cohen 286. Ovoid, struck twice.
170. *Rev.* [P M] TR P II COS.P P. Claudius advancing r., with transverse spear and globe.  
 Mint mark,  $\frac{|}{\Delta}$  Rome.  
 Cohen 216. 269 A.D.
- 171-2. *Rev.* Same inscription. Claudius standing l., with branch and sceptre.  
 Cohen 214, 215. 269 A.D.

173. *Rev.* . . . ] AVG. Draped female figure (SALVS or LIBERTAS ?) standing l., r. hand lowered, l. holding vertical sceptre.
- 174-5. *Rev.* Illegible. Draped female figure standing.
- 176-9. *Rev.* Indecipherable or obliterated.

*Posthumous coins, struck by Quintillus, 270 A.D.*

*Obv.* in all cases : Head or bust, radiate, r. *Rev.*, except in last : CONSECRATIO. 3 Æ. or 3 Æ. Q.

- 180-96. *Rev.* Altar aflame.
- 180-6. Hung with festoon. Cohen 54.
- 187-95. Showing four panels, each with central boss. Cf. Cohen 51 (no details).
196. Divided horizontally and decorated. Cf. Cohen 51 (no details).
- Obv.* DIVO CLAVDIO.
- 197-202. *Rev.* Plain altar without visible details.
197. *Obv.* DIVO CLAVDIO. Cohen 51.
- 198-202. *Obv.* [IMP CLAVDIVS AVG] or [DIVO CLAVDIO]. Illegible.
- Five specimens, including one local imitation. Cohen 48 or 51.
- Rev.* Eagle standing r., head turned l.
203. *Obv.* DIVO CLAVDIO. Cohen 41.
- 204-214. *Rev.* Eagle facing, wings outspread, head turned r.
204. *Obv.* IMP CLAVDIVS AVG. Cohen 45.
- 205-12. *Obv.* DIVO CLAVDIO. Cohen 46.
- 213-14. *Obv.* Illegible. Either of above inscriptions.

*Hybrid*

215. *Rev.* VICTO[RIA AVG]. Victory advancing l., with wreath and palm branch.
- Obv.* DIVO CLAVDIO. Cf. Cohen 292-4.

*Quintillus (270 A.D.)*

- Obv.* in all cases : IMP C M AVR CL QVINTILLVS AVG. 3 Æ.
216. *Obv.* Bust, radiate and cuirassed, r.
- Rev.* CONCOR[DIA] AVG. Concordia standing l. before altar, holding patera in r. hand and double cornucopiae in l.
- Cohen 17.



- 217-18. *Obv.* Bust, radiate and draped, r.  
*Rev.* VICTORIA AVG. Victory advancing r., with wreath  
 and palm branch.  
 Cohen 70.

*Tetricus I* (268-73 A.D.)

- Obv.* in all cases, where legible : IMP (or IMPC) TETRICVS (P F)  
 AVG. 3 Æ. Bust, radiate and draped, r.
- 219-21. *Rev.* COMES AVG. Victory standing l., with wreath  
 and palm-branch.  
 Cohen 17, 18.
- 222-4. *Rev.* FIDES MILITVM. Fides standing l., with a military  
 standard in either hand.  
 Cohen 37-43. (One small)
- 225-9. *Rev.* HILARITAS AVGG. Hilaritas standing l., with tall  
 palm-branch and cornucopiae.  
 One, with silver wash, showing mint mark  | R  
 Cohen 54-6.
- 230-5. *Rev.* LAETITIA AVGG. Laetitia standing l., with wreath  
 and anchor.  
 Cohen 71, 72.
- 236-41. *Rev.* LAETITIA AVGG or AVGN. Same type.  
 Cohen 71 or 75.
- 242-8. *Rev.* PAX AVG. Pax standing l., with olive-branch and  
 vertical sceptre.  
 Cohen 95-9.
249. *Rev.* As above, but with cornucopiae instead of sceptre.  
 Cohen 103.
250. SALVS AVG. Salus standing l., with patera, feeding snake  
 rising from altar on r., and holding an anchor.  
 Cohen 149.
- 251-2. *Rev.* SALVS AVGG. Same type.  
 Cohen 153.
- 253-5. *Rev.* One of the two preceding types.
256. *Rev.* SALVS AVG. As above, but holding vertical sceptre  
 instead of rudder.  
 Cohen 147, 148.

257. *Obv.* . . . . ETRICVS PF AVG.  
*Rev.* SPES PVBLICA. Spes moving l., holding flower and  
 catching up dress.  
 Cf. Cohen 170.
258. *Rev.* As above.  
 Cohen 170.
- 259-60. *Rev.* SPES AVG, AVGG or PVBLICA. Same type.  
 Cohen 158, 163, or 170.
- 261-4. *Rev.* VIRTVS AVGG. Virtus, helmeted, standing l., with  
 shield and spear.  
 Cohen 207.
- 265-9. *Rev.* Illegible. Draped figure, standing l.
- 270-7. *Rev.* Obliterated.

*Local imitations* : all small 3 Æ. or 3 Æ. Q.

278. [FIDES MILITVM?] Fides standing, holding military  
 standard in either hand.  
 Cf. Cohen 37-43.
279. *Obv.* . . . . V Ì Ì V. Head, radiate, r.  
*Rev.* Pellets for lettering. Rough representation of pre-  
 ceding type.
280. *Obv.* . . . ]ETRICVS I A. Head, radiate, r. (not a portrait  
 of Tetricus).  
*Rev.* . . ]X IA [. . Pax standing l., with olive branch and  
 vertical sceptre.  
 Cf. Cohen 100.
281. *Obv.* . . . .] TITECVS[. . .  
*Rev.* . . .]AV. Same type.
- 282-5. *Rev.* Pax type, one with . . .]VGG.
- 286-8. *Rev.* Salus type, one with rudder of exaggerated size.  
 Cf. Cohen 148, 153.
289. *Rev.* Victory (or possibly Comes) type.  
 Cf. Cohen 17, 185.
- 290-3. *Rev.* Indecipherable.

*Tetricus II* (Caesar and Augustus, 268-73 A.D.)

*Obv.* in all cases, where legible : C P E (or C PIV ESV)

TETRICVS CAES.

Youthful bust, radiate and draped, r. 3 Æ.

132 REPORTS OF THE SOCIETY OF ANTIQUARIES

- 294-5. *Rev.* PAX AVG. Pax standing l., with olive branch and vertical sceptre.  
Cohen 36.
- 296-7. *Rev.* PIETAS AVGG. Sacrificial implements, vase turned r.  
Cohen 48.
298. *Rev.* As above, but vase turned l.  
Cohen 53.
- 299-303. *Rev.* SPES AVGG. Spes moving l., holding flower and catching up dress.  
Cohen 88-92.
304. *Rev.* [SPES] PV[BLICA]. Same type.  
Cohen 95-7.
- 305-7. *Rev.* SPES . . . . One of the preceding types.
308. *Rev.* Illegible. Male figure standing l., possibly Virtus.
309. *Obv.* [C PIV ES[VI TETR[ICVS CAES].  
*Rev.* Illegible: standing figure. (Fragment)
- 310-14. *Rev.* Obliterated.

Local imitations

315. *Obv.* . . . .]CVS . I AV . Youthful bust, radiate and draped, r.  
*Rev.* . . . .]E T . . Pax type.  
Cf. Cohen 36. 3 Æ. (Small)
316. *Rev.* Pax type. 3 Æ. (Small)
- 317-19. *Rev.* SPES AVGG. Spes type.  
Cf. Cohen 87. 3 Æ. (Small, 2) 3 Æ Q.
320. *Rev.* . . . .]V A[VG]. Probably Virtus type; male, with shield.  
Cf. Cohen 104.
321. *Rev.* Indecipherable.

*Aurelian* (270-5 A.D.)

322. *Obv.* IMP AVRELIANVS AVG. Bust, radiate and draped, r.  
*Rev.* CONCORDIA MILITVM. Emperor, facing r., and Empress or Concordia, l., join hands.  
Mint mark,  $\frac{|}{P*}$  Rome.  
Cohen 61. 3 Æ. (Large)

*Tacitus* (275-6 A.D.)

323. *Obv.* IMP C M CL TACITVS AVG. Bust, radiate, draped and cuirassed, r.  
*Rev.* PROVIDE AVG. Providentia standing l., holding globe and transverse sceptre.  
 Mint mark, ——— Mediolanum-Ticinum (Webb).  
 Q  
 Cohen 90 (variant). 3 Æ.

*Numerianus* (283-4 A.D.)

324. *Obv.* IMP NVMER[IANV]S AVG. Bust, radiate and cuirassed, r.  
*Rev.* PIET[AS] AVGG. Mercury standing l., with bag and caduceus.  
 Mint mark, ——— Rome (mark transferred from Serdica:  
 ΚΑΔ  
 pay for the Persian War, 283 A.D., Webb, *Num. Chron.*, 5th ser., i, 1921, p. 42).  
 Cohen 57. 3 Æ. (Chipped)

*Carausius* (287-93 A.D.)

All 3 Æ.

325. *Obv.* [IM]P CARAVSIVS P AVG. Bust, radiate, draped and cuirassed, r.  
*Rev.* [CONCORDIA MI]LITVM. Emperor togate standing r., clasping hand of Concordia standing l.  
 Cf. Webb 1263.
326. *Obv.* IMP C CARAVSIVS PF AVG. Bust, radiate and draped, r.  
*Rev.* CONCO[RDIA . . .]. Draped or semi-nude figure seated l., r. hand extended, l. holding vertical sceptre.
327. *Obv.* [IM]P C[A]RAVSI[VS] P F [AVG]. Bust, radiate, r.  
*Rev.* [FIDES] MILITVM. Fides standing l., with standard in either hand.  
 Cf. Webb 876. (Corroded)
328. *Obv.* [IMP CARAV]SIVS P F AVG. Bust, radiate and draped, r.  
*Rev.* L[EG II AVG]. Capricorn bounding l.  
 Mint mark,  $\frac{|}{ML}$  London.  
 Webb 63.

329. *IMP CARAVISIVS* (sic) *P F AVG.* Bust, radiate, draped and cuirassed, r.

*Rev.* *LEG IIII [FLAVIA ?]* Lion passant r.

Mint mark,  $\frac{|}{ML}$  London.

Cf. Webb 88. (Small die on large flange)

330. *Obv.* *IMP CARAVISIVS P* [. . .]. Bust, radiate, draped and cuirassed, r.

*Rev.* [*LEG XXX (?) V*] *LP IA.* Boar (?) r. London mint.

Cf. Webb 109.

331. *Obv.* . . . *CARAVISIVS P* [. . .] Bust, radiate, r.

*Rev.* *MARS VICTOR.* Mars standing r., r. hand holding vertical spear, l. resting on shield. No mint mark.

Cf. Webb 939. (Corroded)

332. *Obv.* *IMP CARAVISIV[S P F AVG].* Bust, radiate and draped, r.

*Rev.* *MARS VLTOR.* Mars, helmeted, standing l., r. hand holding vertical spear, l. resting on shield.

Not in Webb. No mint mark.

333-68. *PAX AVG* types.

333-53. *Rev.* Pax standing l. with olive branch and vertical sceptre.

*Obv.* *IMP CARAVISIVS AVG.*

333. (a) Bust, radiate and draped, r. No mint mark. Webb 977.

334-5. (b) Bust, radiate, draped and cuirassed, r. No mint marks (2), one corroded. Webb 977.

336. *Obv.* *IMP CARAVISIVS P AVG.* Bust, radiate, draped and cuirassed, r. No mint mark. Webb 980.

337-43. *Obv.* *IMP CARAVISIVS P F AVG.*

(a) Bust, radiate and draped, r.

337-9. Mint marks: London  $\frac{|}{MLXXI}$   $\frac{|}{JM}$

uncertain  $\frac{S|P}{—}$ . Webb 128, 526.

340-3. Illegible (1), none (3). Webb 985.

344. (b) Bust, radiate, draped and cuirassed, r. No mint mark. Webb 986.

345. *Obv.* IMP C CARAVSIVS P F AV. Bust, radiate, draped and cuirassed, r.

Mint mark: London  $\frac{F|O}{ML}$ . Not in Webb.

*Obv.* IMP C CARAVSIVS P F AVG.

346. (a) Bust, radiate and draped, r. No mint mark. Webb 999.

347-50. (b) Bust, radiate, draped and cuirassed, r.

Mint marks: London  $\frac{S|P}{ML}$  (2),  $\frac{S|C}{ML}$   $\frac{|||O}{ML}$ .

Webb 139.

351. *Obv.* IMP C M CARAVSIVS P F AVG. Bust, radiate and draped, r.

Mint mark,  $\frac{C|||}{|||}$  Colchester? Cf. Webb 367-8.

352. *Obv.* IMP C CARAVSIVS P F I AVG. Bust, radiate, draped and cuirassed, r. No mint mark. Not in Webb.

353. *Obv.* . . CAR]AVSI[VS . . . . Bust, radiate and draped, r. Mint mark, if any, lost. Not in Webb.

354-62. *Rev.* Pax standing l., with olive branch and transverse sceptre.

354-5. *Obv.* IMP CARAVSIVS AVG. Bust, radiate and draped, r. No mint marks (2). Webb 994.

356. *Obv.* IMP CARAVSIVS P AVG. Bust, radiate and draped, r. No mint mark. Not in Webb.

357-9. *Obv.* IMP CARAVSIVS P F AVG. Bust, radiate and draped, r.

Mint mark, Colchester  $\frac{|}{C}$ . No mint marks (2).

Webb 377, 996.

360-1. *Obv.* IMP C CARAVSIVS P AVG. Bust, radiate and draped, r.

Mint mark, Colchester  $\frac{S|P}{C}$ . No mint mark (1).

Webb 373.

362. *Obv.* . . . CAR]AVSIVS P F AVG. Bust, radiate and draped, r. No mint mark.

363. *Rev.* Pax standing l., with staff and transverse sceptre.  
*Obv.* Illegible. No mint mark.
364. *Rev.* Pax standing l., with olive branch and inverted spear.  
*Obv.* IMP CARAVSIVS P F AVG. Bust, radiate and draped, r.  
No mint mark. Webb 1012.
365. *Rev.* Pax standing l., with olive branch and cornucopiae.  
*Obv.* IMP CARAVSIVS P F AVG. Bust, radiate and draped, r.  
Mint mark, Colchester  $\frac{|}{C}$ . Webb 386.
366. *Rev.* Pax standing l., but only olive branch visible.  
*Obv.* Illegible. Mint mark, if any, lost.
367. *Rev.* Pax standing l., with staff and cornucopiae.  
*Obv.* IMP CARAVSIVS P F AVG. Bust, radiate and cuirassed, r.  
Mint mark, London  $\frac{B \begin{array}{|c|} \hline \text{||||} \\ \hline \end{array}}{MLX}$ . Cf. Webb 156.
368. *Rev.* Salus standing l., feeding serpent rising from altar and holding vertical sceptre.  
*Obv.* IMP CARAVSIVS P F AVG. Bust, radiate and draped, r.  
Mint mark, if any, lost. Cf. Webb 1031.
369. *Obv.* IMP C CARAVS[IVS . . . Bust, radiate and draped, r.  
*Rev.* PROV[ID AVG]. Providentia standing l., holding in l. hand rudder, in r. staff resting on ground between globe and foot.  
Mint mark,  $\frac{S|C}{C}$  Colchester.  
Webb 406 or 407.
370. *Obv.* IMP CARAVSIVS P F AVG. Bust, as above.  
*Rev.* [PROVID]ENT AVG. Providentia standing l. (details corroded).  
Mint mark,  $\frac{[B]E}{MLXXI}$  London. Webb 175.
- 371-2. *Rev.* SALVS AVG. Salus standing l., feeding serpent rising from altar and holding vertical sceptre.  
Two mint marks, if any, illegible. Cf. Webb 1108-9.

373. *Obv.* [IMP] C M·CARAVSIVS AV[G] Bust, radiate, r.  
*Rev.* As above.  
 Webb 1111. (Corroded)
374. *Obv.* IMP C CARAVSIVS P F AVG. Bust, radiate, draped and cuirassed, r.  
*Rev.* VIRTVS AVG. Mars, nude, standing r., holding transverse spear on shoulder.  
 Mint mark,  $\frac{S|C}{[C]}$  Colchester.  
 Not in Webb.
375. *Obv.* IMP CARAVSIVS P F AV. Bust, radiate and draped, r.  
*Rev.* VIRTVS AVG. Mars advancing r., r. hand holding spear.  
 Mint mark, if any, obliterated.  
 Cf. Webb 1173.
376. *Obv.* . . . .]CARAVSIVS[. . . Bust, as above.  
*Rev.* Draped female standing l., possibly FORTVNA, with rudder in r. hand, resting on ground. (Burnt and corroded)
377. *Obv.* . . . . . ]IVS P F AVG. Bust, radiate, draped and cuirassed, r.  
*Rev.* Illegible. Draped female standing l., with wreath in r. hand, possibly LAETITIA. (Corroded)
378. *Obv.* Illegible. Bust, radiate (and draped?), r.  
*Rev.* Figure standing l., with vertical sceptre; probably [PAX A]VG.  
 No mint mark. (Burnt and corroded)
379. *Obv.* IMP C CARAVSIVS P F AVG. Bust, radiate and draped, r.  
*Rev.* . . .]AVG. Draped female standing l., r. hand extended, l. resting on shield.  
 Cf. Webb 19.
- 380-3. *Obv.* Incomplete or illegible. Bust, as above.  
*Rev.* Obliterated. (Corroded or burnt)
- 384-5. *Obv.* Incomplete. Bust, radiate and cuirassed, r.  
*Rev.* Illegible or obliterated. Draped standing figure. (One burnt)



*Allectus* (293-7 A.D.)

Obverse, unless otherwise stated : IMP C ALLECTVS  
P F AVG. 3 Æ.

386. *Obv.* Bust, radiate and cuirassed, r.  
*Rev.* LAETITIA AVG. Laetitia standing l., with wreath  
and anchor.  
Mint mark,  $\frac{S|A}{ML}$  London.  
Webb 28.
387. *Obv.*, Bust, radiate, draped and cuirassed, r.  
*Rev.* PAX AVG. Pax standing l., holding olive branch and  
vertical sceptre.  
Mint mark,  $\frac{S|A}{MSL}$  London.  
Webb 38.
388. *Obv.* As above, but cuirassed only.  
*Rev.* As above.  
Mint mark,  $\frac{S|A}{ML}$  London.  
Webb 39.
389. *Obv.* Bust, radiate, draped and cuirassed, r.  
*Rev.* PAX IIAG. Pax, as above.  
No mint mark.  
Cf. Webb 197.
390. *Obv.* Bust, radiate and draped, r.  
*Rev.* PAX AVG. Pax, as above, but with transverse  
sceptre.  
Mint mark,  $\frac{S|A}{ML}$  London.  
Webb 42.
- 391-2. *Obv.* Bust, radiate and cuirassed, r.  
*Rev.* As above.  
Mint marks,  $\frac{S|A}{ML}$  (2), London.  
Webb 44.

393. *Obv.* As above.  
*Rev.* TEMPORVM FELIC. Felicitas standing l., holding  
 caduceus and cornucopiae.  
 Mint mark,  $\frac{S|P}{C}$  Colchester.  
 Webb 177.
394. *Obv.* Bust, radiate, draped and cuirassed, r.  
*Rev.* VICTORIA AVG. Victory standing l., with wreath  
 and palm.  
 Mint mark,  $\frac{S|P}{ML}$  London.  
 Webb 80.
395. *Obv.* Bust, radiate and draped, r.  
*Rev.* VIRTVS AVG. War-galley to l., with five oars (and  
 bird (?) on mast).  
 Mint mark,  $\frac{|}{QL}$  London.  
 Webb 88.
396. *Obv.* Bust, radiate and cuirassed, r.  
*Rev.* As above (but no bird on mast).  
 Mint mark,  $\frac{|}{QL}$  London.  
 Webb 89.
397. *Obv.* IMP C ALLECTVS P AVG. Bust, radiate and cui-  
 rasssed, r.  
*Rev.* As above. Five oars and six rowers.  
 Mint mark,  $\frac{|}{QC}$  Colchester.  
 Webb 187.
398. *Obv.* . . . A]LLEC[TVS . . . Bust, radiate, r.  
*Rev.* Obliterated.

*Radiate Crowns (260-97 A.D.)*

## Uncertain Attribution.

*Obv.* in all cases: Head or bust, radiate, r.

B. Antoniniani and silver washed.

399-402. *Rev.* Illegible.

3 Æ.

403. *Rev.* CONSECRATIO. Eagle.404-6. *Rev.* FIDES MILITVM type.

- 407-8. *Rev.* LAETITIA type.  
 409-21. *Rev.* PAX type, with vertical or transverse sceptre.  
 422. *Rev.* VBERITAS type.  
 423. *Rev.* Victory advancing r.  
 424. *Rev.* Victory advancing l.  
 425. *Rev.* VIRTVS type.  
 426-85. *Rev.* Indecipherable (60).

Local Imitations. 3 Æ. small, or 3 Æ. Q.

486. *Rev.* Standing figure; 2 in field, l.  
*Obv.* ∩VG ∩∩I•∩∩CRV∩ (*sic*). ? Intended for Carausius  
 Aug.  
 487. *Rev.* Male figure (? armed) standing r. . . IY . NI.  
 488. *Rev.* Female figure standing r. IAI • • .  
 489. *Rev.* Draped figure standing in rude galley. . . XX . . .  
 490. *Rev.* Draped figure standing with vertical sceptre.  
 . . . USAII .  
 491. *Rev.* Hilaritas type.  
 492-5. *Rev.* Pax type.  
 496-7. *Rev.* Spes type.  
 498-546. *Rev.* Indecipherable (49).

*Diocletian* (284-305 A.D.)

547. *Obv.* IMP C C VAL DIOCLETIANVS P F AVG. Bust,  
 radiate and draped, r.  
*Rev.* IOVI CONSERVATORI. Jupiter, nude, standing l., with  
 thunderbolt and sceptre.

Mint mark, D| .

Cohen 259. 3 Æ.

548. *Obv.* IMP C DIOCLETIANVS P F AVG. Bust, laureate, r.  
*Rev.* SACRA MONET AVGG ET CAESS NOSTR. Moneta  
 standing l., with scales and cornucopiae.

Mint mark, SΩT Ticinum.

Cohen 436. 2 Æ. (*Follis*) 296-305 A.D.

*Maximianus Hercules* (Caesar 285 A.D., Augustus  
 286-305 A.D.)

549. *Obv.* IMP C MAXIMIANVS P F AVG. Bust, laureate and  
 cuirassed, r.  
*Rev.* GENIO POPVLI ROMANI. Genius, semi-nude, wear-  
 ing the modius, standing l., with patera and cornu-  
 copiae; pallium hanging from l. arm.

No mint mark (London mint?).

Cohen 180. 2 Æ. (*Follis*) Same date.

550. IMP C VAL MAXIMIANVS P F AVG. Bust, radiate and draped, r.

Rev. HERCVLI PACIFERO. Hercules, nude, standing l., with laurel branch and club; lion's skin over l. arm.

Mint mark,  $\frac{B|}{SML}$  Lyons.

Cohen 282. 3 Æ. (Silver washed) 286-96 A.D.

551. Obv. IMP MAXIMIANVS P F AVG. Bust, laureate (?) and cuirassed, r.

Rev. Within a laurel wreath: VOT [? XX].

Cf. Cohen 681. 3 Æ. Q. (*Centenionalis*)

*Galerius* (Caesar 292 A.D., Augustus 305-11 A.D.)

552. Obv. MAXIMIANVS NOBIL C. Bust, laureate, and cuirassed r.

Rev. GENIO POPVLI ROMANI. Genius, as in no. 549.

Mint mark,  $\frac{S|F}{STR}$  Trier.

Cohen 65. 2 Æ. (*Follis*) 296-305 A.D.

*Fl. Val. Severus* (II). (Caesar 305-6, Augustus 306-7 A.D.)

553. Obv. SEVERVS NOB CAESAR. Bust, laureate, r.

Rev. VIRTVS AVGG ET CAESS NN. Virtus, helmeted and nude, advancing r., with spear and trophy.

Mint mark,  $\frac{*|}{\bullet TT}$  Ticinum.

Cohen 70. 2 Æ. (*Follis*) 1 May 305-25 July 306.

Uncertain Attribution. c. 296-313 A.D.

554-5. Obv. Illegible. Busts, r.

Rev. GENIO POPVLI ROMANI. Genius, as in no. 549.

2 Æ. (*Folles*) Corroded.

*Constantine I, The Great* (Caesar 306, Augustus 307-37 A.D.)

Rev. BEATA TRANQVILLITAS. Altar inscribed VOTIS XX; thereon, a globe; above, three stars. 3 Æ. 320-24 A.D.

556. Obv. CONSTANTINVS AVG. Bust, helmeted and cuirassed, r.

Mint mark,  $\bullet PTR \bullet$  Trier.

Cohen 20.

557-8. *Obv.* CONSTANTINVS AVG. Bust, laureate and cuirassed, r.

Mint marks,  $\overline{\text{PTR}} \overline{\text{PTR}}$  Trier.  
Cohen 16.

559. *Obv.* CONSTANTINVS P F AVG. Bust, laureate and cuirassed, r.

Mint mark,  $\frac{\text{C|R}}{\text{PLG}}$  Lyons.

Cohen 25.

560. *Obv.* IMP CONSTANTINVS AVG. Bust, helmeted and cuirassed, r.

Mint mark lost.

Cf. Cohen 20.

561. *Obv.* CONSTANTINVS MAX AVG. Bust, laureate and draped, r.

*Rev.* GLORIA EXERCITVS. Two soldiers facing, each holding a spear and resting on a shield; between them, two standards.

Mint mark,  $\overline{\text{TR}\cdot\text{P}}$  Trier.

Cohen 255. 3 Æ. 330-3 A.D.

562-3. *Obv.* As above, but bust diademed and draped, r.

*Rev.* As above.

Mint marks,  $\overline{\text{TRS}\ast}$  Trier. 330-3 A.D.

$\overline{\text{SMNS}}$  Nicomedia. 333-5 A.D.

Cohen 254. 3 Æ.

564. *Obv.* As above.

*Rev.* As above, but between soldiers, one standard.

Mint mark,  $\overline{\text{TRP}}$  Trier. 335-7 A.D.

Cohen 250. 3 Æ.

565-6. *Obv.* CONSTANTINVS AVG. Bust, laureate, r.

*Rev.* SARMATIA DEVICTA. Victory advancing r., holding trophy and palm branch; before her, a seated captive.

Mint mark,  $\overline{\text{PTR}} \smile$  Trier.

One illegible mint mark.

Cohen 487. 3 Æ. (One large) 320-4 A.D.

567-8. *Obv.* IMP CONSTANTINVS AVG. Bust, laureate and cuirassed, r.

*Rev.* SOLI INVICTO COMITI.

Sol, radiate, standing l., r. hand extended, l. holding globe ; pallium over l. arm. 3 Æ. 313-17 A.D.

Mint marks,  $\overline{\text{STR}} \cdot \overline{\text{ATR}}$  Trier.  
Cohen 530.

569. *Obv.* CONSTANTINVS P F AVG. Bust, as above.

*Rev.* as preceding. Mint mark illegible.

Cf. Cohen 525. 3 Æ. (Small)

570. SOLI INVICTO COMITI. Bust of Sol, radiate and draped, r.

*Obv.* IMP CONSTANTINVS AVG. Bust, as above.

No mint mark visible (corroded).

Cohen 511. 3 Æ. (Large) 313-17 A.D.

*Rev.* VICTORIAE LAETAE PRINC PERP. 3 Æ. 820-24 A.D.

571-2. (a) Two Victories facing and placing on cippus a shield inscribed VOT PR.

*Obv.* IMP CONSTANTINVS AVG. Bust, helmeted and cuirassed, r.

Mint mark,  $\overline{\text{STR}}$  Trier, and one illegible.

Cf. Cohen 636.

573. (b) Similar, but, instead of cippus, a circular altar bearing a Greek cross.

*Obv.* IMP CONSTANTINVS MAX AVG. Bust as above.

Mint mark,  $\overline{\text{TT}}$  Ticinum.

Cohen 640.

574. *Obv.* CONSTANTINVS NOB CAES. Bust, laureate and draped, r.

*Rev.* VIRTVS AVGG ET CAESS NN. Constantine galloping r., with shield on l. arm, spearing two foes beneath horse.

Mint mark,  $\overline{\text{PT}}$  Ticinum.

Cohen 675. 2 Æ. (*Follis*) 306 A.D.

Consecration Coins. 337 A.D.

575-6. *Obv.* DIV CONST[ANTINVS P T AVGG.] Bust, veiled, r.

*Rev.* No inscription. Constantine I driving quadriga r., extending r. hand to hand from above.

Cohen 760. 3 Æ. small and 3 Æ. Q.

577. *Obv.* [DIVO CONSTANTINO]. Bust, veiled, r.  
*Rev.* AETERNA PIETAS. Constantine I, in military costume, standing r., holding reversed spear in r. hand and globe in l. ; drapery hanging from l. arm.

Mint mark,  $\frac{|X}{LVG}$  Lyons.

Cohen 13. 3 Æ. Q.

*Constantine Period.* (Constantinopolis)

- 578-622. *Obv.* CONSTANTINOPOLIS. Bust of Constantinopolis, helmeted, l., with sceptre over shoulder.  
*Rev.* Victory standing l., with spear and shield, placing r. foot on prow of vessel. 3 Æ., mostly small ; five, 3 Æ. Q.

Mint marks:

578-9. Aquileia:  $\overline{AQP} \overline{AQ} \text{■}$ .

580-90. Lyons:  $\overline{PLG}$  (5),  $\bullet\overline{PLG} \overline{PL} \text{■}$   $\text{■} \overline{L} \text{■}$   $\text{■} \overline{LG}$  (3).

591. Siscia:  $\overline{BSIS}$ .

592-608. Trier:  $\overline{TR\bullet P}$  (4),  $\overline{TRP}$  (5),  $\overline{\Omega} \overline{TRP} \overline{TRP\bullet}$  (3),  
 $\overline{TRS}$  (2),  $\text{■} \overline{RS} \overline{TR} \text{■}$ .

609. Uncertain:  $\overline{\Omega} \text{■}$ .

610-22. Thirteen illegible or cut off.

Cohen, Constantinople, vii, pp. 326, 21, 22. 330-7  
 A. D.

623. *Obv.* [CONSTAN]TINOPOL. Same type.  
*Rev.* As above.  
 Mint mark lost.

Local Imitations

- 624-33. *Obv.* Same type. Usually illegible ; one bears CONS.  
*Rev.* Same type, roughly represented. 3 Æ. Q. Two very small.
- 634-5. *Obv.* Similar type, but head of Constantinopolis to r., with sceptre ; one reads CON.  
*Rev.* As preceding. 3 Æ. Q. One very small.  
 Cf. Cohen 23.

*Urbs Roma*

- 636-84. *Obv.* VRBS ROMA. Bust of Roma l., helmeted and wearing imperial mantle.  
*Rev.* She-wolf l., suckling Romulus and Remus ; above, two stars.  
 3 Æ. small, except four 3 Æ. Q. and two half quinarii.  
 Mint marks :  
 636. Arles:  $\overline{\text{CONST.}}$   
 637-51. Lyons:  $\overline{\text{PLG}}$  (10),  $\overline{\cup\text{PLG}}$   $\overline{* \text{PLG}}$   $\overline{\text{SLG}}$   $\overline{\text{SLG}}$   
 $\overline{\text{PL}}$   
 652. Rome:  $\overline{\text{R}\Omega\text{Q.}}$   
 653-75. Trier:  $\overline{\text{TRP}}$  (4),  $\overline{\text{TR}\cdot\text{P}}$  (4),  $\overline{\text{TRP}\cdot}$  (3),  $\overline{\text{TR}\curvearrowright\text{P}}$   
 $\overline{\text{TRS}}$  (6),  $\overline{* \text{TRS}}$   $\overline{\text{TRS}}$   $\overline{\text{TRS}*}$   $\overline{\text{TR}}$  (2).  
 676. Uncertain:  $\overline{\Omega}$   
 677-84. Illegible or cut off, 8.  
 Cf. Cohen, vii, *Rome*, pp. 330-1, 17-19.

## Local Imitations

- 685-6. *Obv.* As above, inscription lost.  
*Rev.* As above, crudely drawn.  
 Mint mark,  $\overline{\text{NC}\curvearrowright}$  (*sic*). ? Imitation of Nicomedia mint mark. One without mint mark.  
 3 Æ. Q. and half quinarius.

## Hybrid Types

- 687-8. *Obv.* CONSTANTINOPOLIS. Usual type as above (no. 578).  
*Rev.* GLORIA EXERCITVS. Two soldiers facing ; between them, two standards.  
 Mint mark,  $\overline{\text{PLG}}$  (2), Lyons.  
 Cohen, vii, *Rome*, p. 327, 2. 3 Æ. (Small) 330-5 A. D.  
 689. *Obv.* CONSTANTINOILIS (*sic*). Type of Constantinopolis.  
*Rev.* As preceding.  
 3 Æ. (Small) Blundered imitation. About the same date.



690. *Obv.* VRBS ROMA. Usual type as above (no. 636).  
*Rev.* Type of Constantinopolis.  
 Cohen, vii, *Rome*, p. 329, 12. 3 Æ. (Small) 330-7 A. D.
691. *Obv.* VRBS ROMA. Usual type.  
*Rev.* Type of Constantinopolis.  
 3 Æ. Q. Local imitation. About the same date.

*Pop. Romanus*

- 692-3. *Obv.* POP ROMANVS. Youthful bust, laureate and draped, l., with cornucopiae over l. shoulder.  
*Rev.* Within an oak wreath, an eight-point star.  
 Mint mark in centre CONS IA Constantinople.  
 One mint mark illegible.  
 Cohen, vii, *Le peuple romain*, p. 332, 2. 3 Æ. Q.  
 c. 337 A. D.
694. *Obv.* As above.  
*Rev.* Bridge with tower at either end and water flowing beneath.  
 Between the towers, mint mark, <sup>CONS</sup><sub>A</sub> Constantinople.  
 Cohen, *loc. cit.*, 1. 3 Æ. (Small) c. 337 A. D.

*Helena* (wife of Constantius Chlorus, Augusta 306 A. D.,  
 d. 328 A. D.)

- 695-703. *Obv.* FL IVL HELENÆ AVG. Bust, diademed and draped, r.  
*Rev.* PAX PVBLICA. Pax standing l., with olive branch and transverse sceptre.  
 Mint marks,  $\overline{\text{TRP}} \overline{\text{TRS}}$  (2),  $\overline{\text{TRS}}$  Trier. Illegible, 5.  
 Cohen 4. 3 Æ. Q. (Commemorative issue) 335-7 A. D.
- 704-5. *Obv.* FL HELENA AVGVSTA. Bust, diademed and draped, r.  
*Rev.* SECVRITAS REIPVBLICAE. Securitas standing, with olive branch in r. hand.  
 Mint mark,  $\overline{\text{PTR}}$  Trier. One illegible.  
 Cohen 12. 3 Æ. Q. 324-6 A. D.

## Local Imitation

706. Rough representation of PAX PVBLICA type.  $\frac{1}{2}$  Q.

*Theodora* (second wife of Constantius Chlorus)

707-14. *Obv.* FL MAX THEODORAE AVG. Bust, laureate and draped, r.

*Rev.* PIETAS ROMANA. Pietas, standing facing, nursing babe in arms.

Mint marks,  $\overline{\text{TRP}}$  (2),  $\overline{\text{TRP}} \not\equiv \overline{\text{TRS}}$  (2), Trier. Illegible, 3.

Cohen 4. 3  $\text{Æ}$ . Q.

*Crispus* (Caesar 317-26 A.D.)

715. *Obv.* IVL CRISPVS NOB CAES. Bust, laureate, wearing imperial mantle; sceptre in r. hand, surmounted by eagle.

*Rev.* BEATA TRANQVILLITAS. On altar, inscribed VOTIS XX, a globe; above, three stars.

Mint mark,  $\overline{\text{PTR}}$  Trier.

Cohen 22. 3  $\text{Æ}$ . 320-4 A.D.

716. *Obv.* FL IVL CRISPVS NOB CAES. Bust laureate and cuirassed, l.

*Rev.* CAESARVM NOSTRORVM. Within laurel wreath: VOT X.

Mint mark,  $\overline{\text{TS}\Delta\text{VI}}$  Thessalonica.

Cohen 47. 3  $\text{Æ}$ . 320-4 A.D.

717. *Obv.* CRISPVS NOB CAES. Bust, laureate, r.

*Rev.* As above.

Mint mark,  $\overline{\text{TA}}$  Arles.

Cohen 41. 3  $\text{Æ}$ . 320-4 A.D.

*Delmatius* (Caesar 335-7 A.D.)

718. *Obv.* FL DELMATIVS NOB CAES. Bust, laureate and cuirassed, r.

*Rev.* GLORIA EXERCITVS. With one standard.

Cohen 10. 3  $\text{Æ}$ .

*Constantine II* (Caesar 317, Augustus 337-40 A.D.)

As Caesar.

719. *Obv.* CONSTANTINUS IVN N C. Bust, helmeted and cuirassed, l.

*Rev.* BEAT TRANQLITAS. On altar inscribed VOTIS XX, a globe; above, three stars.

Mint mark,  $\overline{\text{PLO[N]}}$  London.

Cohen 9. 3 Æ. 320-4 A.D.

720. *Obv.* CONSTANTINVS IVN NOB C. Head (? laureate) r.

*Rev.* CAESARVM NOSTRORVM. Within a wreath, VOT XX.

Mint mark,  $\overline{\text{STR}}$  Trier.

Cohen 38. 3 Æ. 320-4 A.D.

721-34. *Obv.* CONSTANTINVS IVN NOB C (or N C). Bust, laureate and cuirassed, r.

*Rev.* GLORIA EXERCITVS. Two standards.

721. Mint marks,  $\overline{\text{TCONST}}$  Arles.

722-4.  $\overline{\text{PLG}} \cup \overline{\text{PLG}} \text{ } \overline{\text{LG}}$  Lyons.

725-9.  $\overline{\text{TR}\cdot\text{P}} \overline{\text{TRS}} \cdot \overline{\text{TRS}} \ast \overline{\text{TR}} \text{ } \overline{\text{TR}}$  (2) Trier.

730-4. Five illegible.

Cf. Cohen, 122, 124. 3 Æ. (3 small) 330-5 A.D.

735. *Obv.* CONSTANTIIVS (*sic*) IVN N C. Bust as above.

*Rev.* As above.

Mint mark,  $\overline{\text{PLG}}$  Lyons. Blundered coin. 3 Æ. (Small)

736-7. *Obv.* CONSTANTINVS IVN NOB C (or N C). Bust as above.

*Rev.* As above, but one standard.

Mint marks,  $\overline{\text{SLG}}$  Lyons.  $\overline{\text{TRS}}$  Trier.

Cohen, 113, 114. 3 Æ. (Small) 333-7 A.D.

738. *Obv.* CONSTANTINVS IVN NOB C. Bust, laureate and cuirassed, l.

*Rev.* PROVIDENTIAE CAESS. Camp gateway surmounted by two towers; between them, a star.

Mint mark illegible.

Cohen 165. 3 Æ. 324-6 A.D.

739. *Obv.* FL CL CONSTANTINVS IVN N C. Bust, as above, r.

*Rev.* SOLI INVICTO COMITI. Sol, as in no. 567.

Mint mark,  $\frac{\cup}{\text{PLG}}$  Lyons.

Cohen 186. 3 Æ. 317-20 A.D.

740. *Obv.* CONSTANTINVS IVN NOB C. Bust, laureate and draped, r.  
*Rev.* Obliterated. 3 Æ. 317-37 A.D.  
 As Augustus.
741. *Obv.* CONSTANTINVS AVG. Bust, laureate and draped, r.  
*Rev.* GLORIA EXERCITVS. With one standard, the labarum.  
 Cf. Cohen 117. 3 Æ. 337-40 A.D.
742. *Obv.* V[IC] CONSTANTINVS AVG. Bust, diademed and cuirassed, r.  
*Rev.* VIRTVS [AVGVSTI]. Emperor, standing r. in military costume, holding reversed spear and resting on shield.  
 Mint mark,  $\overline{RSP}$  Rome.  
 Cohen 233. 3 Æ. (Small) 337-40 A.D.
- Constantius II (Caesar 323, Augustus 337-61 A.D.)*
- As Caesar.
743. *Obv.* FL IVL CONSTANTIVS NOB C. Bust, laureate and cuirassed, r.  
*Rev.* GLORIA EXERCITVS. Two standards.  
 Cohen 104. 3 Æ. 330-5 A.D.
- 744-5. *Obv.* IVL CONSTANTIVS NOB C. Otherwise *Obv.* and *Rev.* as preceding.  
 Variant of Cohen 104. 3 Æ. (Small)
746. *Obv.* CONSTANTIVS NII (blundered for NC). Otherwise, coin as two preceding.  
 Mint mark,  $\overline{PTR}$  Trier. 3 Æ.
747. *Obv.* FL IVL CONSTANTIVS NOB C. Bust, laureate and cuirassed, r.  
*Rev.* GLORIA EXERCITVS. One standard.  
 Mint mark,  $\overline{TRS}$  Trier.  
 Cohen 92. 3 Æ. (Small) 333-7 A.D.
748. *Obv.* and *Rev.* As preceding, but bust l.  
 Variant not in Cohen. 3 Æ. (Corroded) 333-7 A.D.  
 As Augustus.
749. *Obv.* [D N CONSTANTIVS P F AVG]. Bust, diademed and draped, r.  
*Rev.* [VICTO]RIA [AVGVSTORVM]. Victory seated l., holding in r. hand victoriola on globe, in l. a spear.  
 Cohen 240. Æ. (*Siliqua*) reduced. 341-5 A.D.

750. *Obv.* As preceding, but AVG legible.  
*Rev.* Within a laurel wreath, VOTIS V MVLTVS X.  
 Cf. Cohen 338. *R.* (*Siliqua*) reduced. After 340 A.D.

## FEL TEMP REPARATIO types

*Obv.* Busts, diademed and draped, r. 3 Æ., except when otherwise stated. 345-61 A.D.

*Rev.* Emperor I., spearing falling horseman, who raises l. arm.

751. *Obv.* [D N CONST]ANTIVS AVG.

Mint mark, CONST Arles.




Variant of Cohen 47.



752. *Obv.* [CONSTAN]TIVS P F AVG.

Mint mark, LVGP Lyons.

Variant of Cohen 47.

- 753-8. *Obv.* D N CONSTANTIVS P F AVG.

753-5. Mint marks, CON Arles; SLG PLG Lyons.

756-8. R·M·P RQP Rome. One illegible.

Cohen 47.

*Rev.* As preceding, but horseman does not raise arm.

759. *Obv.* CONSTANTIVS AVG.

Mint mark lost. 3 Æ. Q.



Cohen, variant of 45.

- 760-2. *Obv.* CONSTANTIVS P F AVG.

Mint marks, TR·P Trier; two illegible (one 3 Æ. Q.).

Cohen, variant of 45.

- 763-5. *Obv.* D N CONSTANTIVS P F AVG.

Mint marks, [PA]RL Arles; LG Lyons; TR  Trier.

Cohen 45, 48 (one 3 Æ. Q.).

766. *Rev.* Phoenix standing r. on globe, with wreath in beak.

*Obv.* D N CONSTANTIVS P F AVG.

Mint mark lost.

Cohen 57.

767. *Rev.* Emperor standing l., holds in r. hand victoriola, in l. the labarum.  
*Obv.* CONSTANTIVS P F AVG.  
 Mint mark lost. 3 Æ. Q.  
 Cf. Cohen 38.

GLORIA EXERCITVS types. One standard

*Obv.* FL IVL CONSTANTIVS AVG.

- 768-9. Bust, laureate and cuirassed, r.  
 Mint mark, TRP (2), Trier. 3 Æ.
770. Bust, laureate and draped, r.  
 Mint mark lost. 3 Æ. Q.  
 Cf. Cohen 93. 337-40 A. D.  
*Obv.* CONSTANTIVS AVG.
- 771-2. Bust, laureate and cuirassed, r.  
 Mint mark, TRP ~~✠~~ Trier. 3 Æ. Q.
773. Bust, diademed and draped, r.  
 Mint marks lost (2). 3 Æ.  
 Cf. Cohen 98.
- 774-6. *Obv.* CONSTANTIVS P F AVG. Bust, diademed and draped, r.  
 Mint marks, TRS <sup>M</sup> ~~////~~ Trier, and one illegible. 337-42 A. D.  
 Cohen 99, 100. 3 Æ.
- 777-9. *Obv.* D N CONSTANTIVS P F AVG. Bust, diademed and draped, r.  
*Rev.* SPES REIPVBLICE. Emperor, helmeted, standing l., holds globe in r. hand and inverted spear in l.  
 Mint marks, PCON Arles, and two illegible.  
 Cohen 188. 3 Æ. small (one 3 Æ. Q.). 340-61 A. D.
- 780-2. *Obv.* CONSTANTIVS P F AVG. Bust, diademed and draped, r.  
*Rev.* VICTORIAE DD AVGG Q NN. Two Victories facing, each holding wreath and palm branch.  
 Mint marks,  $\frac{\text{TRP}}{\text{TRP}} \frac{\text{TRS} \text{✠}}{\text{TRS} \text{////}} \text{Trier.}$   
 Cohen 293. 3 Æ. (Small) 340-5 A. D.

*Constans* (Caesar 333, Aug. 337-50 A. D.)

As Augustus.

FEL TEMP REPARATIO types.

*Obv.* Busts, diademed and draped, r. 3 Æ., except when otherwise stated. 345-50 A. D.

783-4. *Rev.* Emperor l., spearing falling horseman.

*Obv.* CONSTANS P F AVG.

Mint marks,  $\overline{\text{TR}} \begin{smallmatrix} \text{||||} \\ \text{||||} \end{smallmatrix}$  Trier, and one illegible.

Cf. Cohen 15, 16. 3 Æ. Q.

785. *Rev.* Same group, but reversed.

*Obv.* CONSTANS P F AVG. Mint mark lost.

Not in Cohen. 3 Æ. (Small)

786-8. *Rev.* Phoenix, radiate, r., on globe.

*Obv.* D N CONSTANS P F AVG.

Mint marks,  $\overline{\text{TRP}}$  (2),  $\overline{\text{TRS}}$  Trier.

Cohen 21.

789-95. *Rev.* Similar, but Phoenix on rock.

*Obv.* D N CONSTANS P F AVG.

Mint marks,  $\overline{\text{TRP}}$  (3),  $\overline{\text{TRP}} \cdot \overline{\text{TR}} \begin{smallmatrix} \text{||||} \\ \text{||||} \end{smallmatrix}$  (2), Trier, and one illegible.

Cohen 22.

796. *Rev.* Constans standing l., holding phoenix on globe and labarum, in a galley steered by Victory seated l.

*Obv.* D N CONSTANS P F AVG.

Mint mark,  $\overline{\text{TRS}}$  Trier.

Cohen 10.

797. *Rev.* Constans advancing r., with head turned l. and spear in l. hand, drags captive from hut on l.; behind the hut, a tree.

*Obv.* D N CONSTANS P F AVG. Bust, diademed and draped, l.

Uncertain mint mark,  $\begin{smallmatrix} \text{||||} \\ \text{||||} \end{smallmatrix} \overline{\text{LP}}$ .

Cf. Cohen 18, 19 (2 Æ.). 3 Æ. (Large)

GLORIA EXERCITVS types. One standard

798. *Obv.* CONSTANS AVG. Bust, diademed and cuirassed, r.

Mint mark,  $\frac{\text{P}}{\text{PLG}}$  Lyons.

Cohen 67. 3 Æ. 337-40 A. D.

*Obv.* Bust, diademed and draped, r.

799-804. CONSTANS P F AVG.

Mint marks,  $\frac{\quad}{\text{SLG}}$  Lyons;  $\frac{\text{M}}{\text{TRS}}$  (2),  $\frac{\text{M}}{\text{TRP}}$  Trier; two illegible.

Cohen 65. 3 Æ. (Two 3 Æ. Q.)

805. FL IVL CONSTANS AVG.

Mint mark,  $\frac{\text{O}}{\text{TRP}}$  Trier.

Cf. Cohen 58. 3 Æ. (Small)

806. FL IVL CONSTANS P F AVG.

Mint mark,  $\frac{\text{TRP}}{\text{TRP}}$  Trier.

Not in Cohen. 3 Æ. (Small)

*Obv.* CONSTANS P F AVG. Bust, diademed and draped, r.

807. *Rev.* \*VICTORIA AVGG\*. Victory advancing l., with wreath in either hand.

Mint mark,  $\frac{\text{P}}{\text{SIS}}$  Siscia.

Cohen 128. 3 Æ. 341-5 A. D.

808-35. *Rev.* VICTORIAE DD AVGG Q NN. Two Victories facing, each holding wreath and palm branch.

808-10. Mint marks,  $\frac{\text{P}}{\text{PARL}}$  (2), Arles;  $\frac{\bullet}{\text{PLG}}$  Lyons.

811-28. Mint marks,

$\frac{\quad}{\text{TRP}}$  (3),  $\frac{\heartsuit}{\text{TRP}}$  (2),  $\frac{\text{P}}{\text{TRP}}$  (3),  $\frac{\text{P}}{\text{TRP}\bullet}$  (2),  $\frac{\text{D}}{\text{TRP}}$

$\frac{\text{S}}{\text{TRP}\bullet}$  (2),  $\frac{\text{S}}{\text{T}\bullet\text{RP}}$   $\frac{\text{E}}{\text{TRP}}$   $\frac{\text{T}}{\text{TRP}}$   $\frac{\heartsuit}{\text{TRS}}$   $\frac{\text{E}}{\text{TRS}}$  Trier.

829-30.  $\frac{\text{E}}{\text{TRP}}$   $\frac{\text{D}}{\text{TRP}}$  Trier.

831-5. Uncertain  $\frac{\text{P}}{\text{TRP}}$  and four illegible.

Cohen 179. 3 Æ. and 3 Æ. Q. 341-5 A. D.

836. *Obv.* D N CONSTANS P F AVG. Bust, diademed and draped, r.

*Rev.* VICTORIAE DD AVGG Q NN. As above.

Mint mark,  $\frac{\text{D}}{\text{TRP}}$  Trier.

Not in Cohen. 3 Æ. (Small) 341-5 A. D.



837. *Obv.* FL IVL CONSTANS AVG. Bust, laureate and draped, r.  
*Rev.* VIRTVS AVGG NN. Emperor, helmeted, standing l. with reversed spear and shield.  
 Mint mark,  $\overline{\bullet\text{TRP}\bullet}$  Trier.  
 Cf. Cohen 183. 3 Æ. 337-40 A.D.
838. *Obv.* D N CONSTANS P F AVG. Head, diademed, r.  
*Rev.* Within a laurel wreath, VOT XX MVLT XXX.  
 Mint mark,  $\overline{\text{CON}}$  Arles.  
 Cohen 197. 3 Æ. (Small) Probably 343 A.D.

*Constantius II or Constans*

- Obv.* in all cases, complete or illegible. Busts, diademed and draped, r., except when otherwise stated.  
 FEL TEMP REPARATIO types. 345-61 A.D.
- 839-50. *Rev.* Emperor spearing falling horseman. In some instances, he raises his l. arm.  
 Mint marks,  $\overline{\text{PARL CON}}$  Arles;  $\overline{\text{CONSX}}$  Constantinople;  $\overline{\text{SMK}}$  Cyzicus;  $\overline{\text{TRP TRS}}$  Trier;  $\overline{\text{TPSC}}$  (*sic*) Uncertain.  
 Five illegible. 3 Æ. small. Two 3 Æ. Q.
- 851-2. *Rev.* Phoenix, radiate, standing r., on globe.  
 Two illegible mint marks. 3 Æ. small.
- 853-4. *Rev.* Phoenix, radiate, standing r., on rock.  
 Mint mark,  $\overline{\text{TRP}\bullet}$  and one illegible. 3 Æ. and 3 Æ. Q.
855. *Rev.* Design obliterated. Mint mark lost. 2 Æ.
- 856-7. *Rev.* GLORIA EXERCITVS. One standard.  
*Obv.* FL IVL CONS[. . . . Bust, laureate and cuirassed, r.  
 Mint mark,  $\overline{\text{TRS}}$  Trier, and one illegible. 3 Æ. Q.  
 335-40 A.D.
858. *Rev.* SPES REIPVBLICE. Emperor standing l. with globe and inverted spear.  
 Mint mark,  $\overline{\text{CONS}}$  Constantinople. 3 Æ. 340-61 A.D.
- 859-86. *Rev.* VICTORIAE DD AVGG Q NN. Two Victories facing, holding each a wreath and palm branch.  
 859-62. Mint marks :

$\overline{\text{AR}}$  Arles;  $\overline{\text{Pi}}$  Lyons.

863-72.  $\frac{\text{TRP}}{\text{TRP}} \frac{\text{TRP}}{\text{TSP} \cdot} (2), \frac{\text{TRS}}{\text{TRS}} \frac{\text{D}}{\text{D}} \frac{\text{D}}{\text{D}} (2),$   
 $\frac{\text{D}}{\text{TRP}} (2), \text{Trier.}$

873-6.  $\frac{\text{M}}{\text{M}} \frac{\text{S}^*}{\text{S}} \frac{\text{TRP}}{\text{TRP}} \frac{\text{R}}{\text{R}}$  Uncertain.

877-86. Ten illegible. 3 Æ. small, 3 Æ. Q. 340-5 A. D.

#### Local Imitations

887-924. *Rev.* FEL TEMP REPARATIO. Type: Emperor I. spearing falling horseman; crude representation, usually with incomplete or no inscription.

'Mint mark' CSIS (2), Siscia, and thirty-six other specimens, mostly 3 Æ. Q., but a few 3 Æ. or 3 Æ. small.

925. *Rev.* Same type. No inscription visible.

*Obv.* FEL TEMP written outwards. Head, r. 3 Æ. ovoid.

926-7. *Rev.* Rough representation of VICTORIAE DD AVGG Q NN type. 3 Æ. Q.

#### House of Constantine

#### Uncertain Attribution

928-48. *Rev.* GLORIA EXERCITVS. Two standards.

*Obv.* Diademed and draped, r. (Constantius II?).

928-30. Mint marks, PLG (2), SLG Lyons.

931-5. CSIS. Siscia; TRS (4), Trier.

936-48. Thirteen illegible, of which at least one is a local imitation.

All sizes from 3 Æ. to half-quinarii. 330-5 A. D.

*Rev.* GLORIA EXERCITVS. One standard.

949. *Obv.* Bust, laureate and cuirassed.

Mint mark, SLG (?) Lyons. 3 Æ.

950-1005. *Obv.* Bust, diademed and draped, r.

950-4. Mint marks,

$\frac{\cdot}{\text{ARL}} \frac{\text{PCONST}}{\text{PCONST}} \frac{\text{G}}{\text{G}} (2), \frac{\text{G}}{\text{G}}$  Arles.

955-6.  $\frac{\text{S}}{\text{PLG}} \frac{\text{S}}{\text{PLG}}$  Lyons.

957-66.  $\frac{\text{TRP}}{\text{TRP}} \frac{\text{TRP}}{\text{TRP}} \frac{\text{TRS}}{\text{TRS}} (5), \frac{\text{M}}{\text{TRS}} (2) \frac{\text{V}}{\text{TRS}}$  Trier.

- 967-70.  $\frac{M}{\text{|||||}}$   $\frac{V}{\text{|||||}}$   $\frac{S}{\text{|||||}}$   $\frac{\text{---}}{\text{|||||}}$  Uncertain.
- 971-1005. Thirty-five illegible, of which at least eleven are local imitations.  
Four 3 Æ., twenty 3 Æ. small, twenty-six 3 Æ. Q., six half-quinarii. 335-42 A. D.
- 1006-9. *Rev.* VIRTVS AVGG NN. Emperor, helmeted, standing l., with spear and shield. Two 3 Æ. small, two 3 Æ. Q. (one local imitation). Mint marks illegible. 337-40 A. D.  
*Obv.* Bust, diademed and draped, r., with incomplete inscription.
1010. *Rev.* Two Victories supporting a wreathed shield, inscribed  
VOT  
NT. 3 Æ. Q.  
\*
- 1011-18. *Rev.* Obliterated. One 3 Æ., five 3 Æ. small, two 3 Æ. Q.

## Local Imitations

1019. *Obv.* . . . ]STAN[. . . . Good lettering. Head, l.  
*Rev.* A confused jumble. 3 Æ.
1020. *Obv.* Blurred inscription. Youthful head, r.  
*Rev.* . . .]AVGG NN inscribed outwards. Two Victories holding a wreath; within it,  $\frac{XXX}{\square}$ .  
'Mint mark',  $\frac{\text{---}}{\text{CMIA}}$ . 3 Æ.
1021. *Obv.* VICTORIA. Rough bust, diademed and draped, r.  
*Rev.* . . . S P F AVG. Emperor l., spearing falling horseman.  
Blundered Fel Temp Reparatio type. 3 Æ.

*Magnentius* (350-3 A. D.)

1022. *Obv.* D N MAGNEN[TIVS] P F AVG. Bare head, bust draped, r. Behind head, letter A.  
*Rev.* [FELICITAS] REIP[VBLICAE]. Emperor standing l., holding Victoriola on globe in r. hand, and labarum in l.  
Mint mark,  $\frac{|A}{\text{TR}}$  Trier.  
Cohen 8. 2 Æ. (small). 350-1 A. D.

1023. *Obv.* IM CAE MAGNENTIVS P F AVG. As above.  
*Rev.* FEL TEMP REPARATIO. Emperor standing l., with Victoriola and labarum, in galley steered by seated Victory. Mint mark illegible.  
 Cohen 11. 3 Æ. 350-1 A. D.
1024. *Obv.* D N MAGNENTIVS P F AVG. As above, without letter A.  
*Rev.* GLORIA ROMANORVM. Emperor on horseback r., with shield, about to spear a kneeling figure with hands upraised; below horse, broken spear and shield.  
 Mint mark,  $\overline{[A]MB}$  Amiens.  
 Cohen 21. 3 Æ. (heavy).
1025. *Obv.* As preceding, with letter A.  
*Rev.* As preceding, but broken arms indistinguishable.  
 Mint mark,  $\overline{RPLC}$  Lyons.  
 Cf. Cohen 20. 2 Æ.
- 1026-9. *Obv.* As above.  
*Rev.* VICTORIAE DD NN AVG ET CAES. Two Victories facing, holding a wreath; within it, VOT V MVLX.  
 Mint marks,  $\overline{\quad}$  Amiens. 3 Æ.  
 $\overline{AMB}$   
 $\overline{\quad}$  (2), Trier. 2 Æ.  
 $\overline{TRP}$   
 $\overline{\quad}$  Trier. 2 Æ.  
 $\overline{TRS}$   
 Cohen 68. 2 Æ. 351-3 A. D.
1030. *Obv.* As above.  
*Rev.* VIC[TORIAE DD NN AVG ET] CAE. As above, but VOT V MVLX.  
 Mint mark,  $\overline{\quad}$  Lyons.  
 $\overline{\cup P L G}$   
 Cohen 69. 3 Æ. 351-3 A. D.
1031. *Obv.* As above, without letter A.  
*Rev.* [VICTORIAE D]D NN AG ET CAE. As above, but VOT V MVLX only.  
 Mint mark,  $\overline{\quad}$  Lyons.  
 $\overline{R \text{ } \text{||||} \text{ } LG}$   
 Cf. Cohen 71. 3 Æ. Q. 351-3 A. D.

1032. *Obv.* As above, with letter A.  
*Rev.* VICTORIAE DD NN AVG ET CAES. As above, but  
 VOT NDT X.  
 Mint mark,  $\frac{\quad}{\text{RPLG}}$  Lyons.  
 Cf. Cohen 71. 3 Æ. (small). 351-3 A.D.

*Decentius* (Caesar 351-3 A.D.)

1033. *Obv.* [DN DE]CENTIVS [NOB CAES]. Head bare, bust  
 draped, r.  
*Rev.* [VICTORIAE DD NN AVG ET CAES] (or variant).  
 Two Victories, facing, holding on a cippus a  
 shield inscribed VOT V MVLX.  
 Cohen 44. 3 Æ. (chipped.)

*Magnentius* or *Decentius*

1034. *Obv.* Illegible. Head bare, bust draped, r.  
*Rev.* Obliterated. 3 Æ. 350-3 A.D.
- 1035-6. *Obv.* Indecipherable.  
*Rev.* Type of two Victories holding wreath; within it  
 [VOTV] MVLX.  
 Mint mark,  $\frac{\quad}{\text{DPLV}}$  Lyons. One illegible.  
 3 Æ. (chipped), 3 Æ. (small). 351-3 A.D.
1037. *Obv.* Indecipherable.  
*Rev.* As above, but VOT V MVLX.  
 Mint mark,  $\frac{\quad}{\text{RLC}}$  Arles or Lyons.  
 3 Æ. 351-3 A.D.

## Local Imitations

1038. *Obv.* . . . VS OFA . . . . Head, bare, r.  
*Rev.* As above, but OT MVI X. 3 Æ. Q.
1039. *Obv.* Head bare, bust (? cuirassed), r.  
*Rev.* Type of Two Victories, placing shield on cippus.  
 3 Æ.

*Julian* (Caesar 355, Augustus 361-3 A.D.)

1040. *Obv.* FL CL IVLIANVS P F AVG. Bust, diademed and  
 draped, r.  
*Rev.* VOT X MVLX XX, within a laurel wreath.  
 Cohen 146. AR. (*Siliqua*) 361-3 A.D.

1041. *Obv.* D N FL CL IVLIANVS P F AVG. Bust, as above.  
*Rev.* As above.  
 Mint mark,  $\overline{S\ CONS[T]}$  Arles.  
 Cohen 148. *R.* (*Siliqua*) 361-3 A. D.

Uncertain Attribution (Constantius II, Constans, or Julian)

- 1042-6. *Obv.* Incomplete or illegible. Bust, draped, r.  
*Rev.* [SPES REIPVBLICE]. Emperor, helmeted, standing l., holds globe in r., and vertical spear or labarum in l. 3  $\mathcal{A}$ . (small, 5).

*Jovian* (363-4 A. D.)

1047. *Obv.* D N IOVIANVS P F AVG. Bust, diademed and draped, r.  
*Rev.* VOT V MVLT X, within a laurel wreath.  
 Mint mark,  $\overline{T\ CONS[T]}$  Arles.  
 Cohen 33. *R.* (*Siliqua*)

*Valentinian I* (364-75 A. D.)

- Obv.* in all cases: D N VALENTINIANVS P F AVG. Bust, diademed and draped, r.  
 1048-63. *Rev.* GLORIA ROMANORVM. Emperor, standing or advancing r., placing r. hand on head of kneeling captive, and holding labarum in l.  
 1048. Arles mint mark:  $\overline{SCON}$ .

1049-57. Lyons mint marks:

$\overline{\quad\quad\quad} \frac{O|F\ II}{LVGP} (4), \frac{O|F\ II}{LVGSP} \frac{O|F\ II}{LVGD\cdot} \frac{O|F\ II}{LVGSD} (2).$

1058-9. Siscia mint marks:  $\overline{\quad\quad\quad} \frac{\mathcal{A}|F}{BSISG\cdot} [\overline{SISC}]$

1060. Sirmium mint mark:  $\overline{\bullet SIRM}$

1061. Trier mint mark:  $\overline{TRP}$

1062-3. Two mint marks illegible or cut off.

Cohen 12. 3  $\mathcal{A}$ .

- 1064-87. *Rev.* SECVRITAS REIPVBLICAE. Victory advancing l. with wreath and palm branch.

1064-7. Aquileia mint marks:

$\overline{\quad\quad\quad} (2), \frac{*|}{SMAQP} \frac{D|}{SMAQP}$

1068-74. Arles mint marks:

$$\overline{\text{CON}} \quad \overline{\text{P CON}} \quad (2), \quad \overline{\text{P CONST}} \quad \overline{\text{OF|I}} \quad \overline{\text{OF|I}} \quad \overline{\text{N|}} \quad \overline{\text{SCON}}$$
1075. Lyons mint mark:  $\frac{\overline{\text{OF|I}}}{\text{LVGPS}}$ 1076-7. Siscia mint marks:  $\frac{\text{R|F}}{\text{A}}$      $\frac{\text{R|F}}{\text{A}}$   
 $+\text{SISC}\Sigma \cdot \Gamma\text{SISCP}$ 1078. Trier mint mark:  $\overline{\text{TRP}} \smile$ 1079. Uncertain mint:  $\frac{\overline{\text{OF|II}}}{\text{////}}$ 1080-7. Eight mint marks illegible or cut off.  
Cohen 37. 3 Æ.*Valens (364-78 A.D.)*1088-95. *Obv.* in all cases: D N VALENS P F AVG. Bust, diademed and draped, r.*Rev.* GLORIA ROMANORVM. Type like that of Valentinian I.1088. Aquileia mint mark:  $\overline{\text{SMAQS}}$ 1089-90. Lyons    „    marks:  $\frac{\overline{\text{O|F|I}}}{\text{[L]VGP}}$      $\frac{\overline{\text{O|F|I}}}{\text{LVG PP}}$ 1091. Rome    „    mark:  $\overline{\text{SMRQ}}$ 1092. Siscia    „    „     $\frac{\text{A}}{\text{SISC}}$ 1093-5. Three mint marks illegible or cut off.  
Cohen 4. 3 Æ.1096-1134. *Rev.* SECVRITAS REIPVBLICAE. Type like that of Valentinian I.

1096-1100. Aquileia mint marks:

$$\frac{\text{f|}}{\text{SMAQP}} \quad \overline{\text{SMAQS}} \quad (4).$$

1101-9. Arles mint marks:

$$\overline{\text{PCON}} \quad \overline{\text{PCONST}} \quad \overline{\text{SCON}} \quad \overline{\text{TCONST}}$$

$$\frac{\overline{\text{OF|I}}}{\text{CONST}} \quad \frac{\overline{\text{OF|II}}}{\text{SCON}} \quad \frac{\overline{\text{OF|II}}}{\text{CONST}} \quad \frac{\overline{\text{OF|III}}}{\text{CONST}^{\circ}} \quad \frac{\overline{\text{V|A}}}{\text{PCON}}$$

1110-13. Lyons mint marks:

$\frac{OF|I}{LVGP}$   $\frac{OF|I}{LVGP}$   $\frac{OF|II}{LVGPS}$   $\frac{N|S}{LVGP}$

1114-17. Rome mint marks:

$\frac{\Omega|}{RQVARTA}$   $\frac{\Omega|}{RQVART[A]}$   $\frac{\Omega|}{[RQ]VART[A]}$   $\frac{\Omega|}{SMRA}$

1118-21. Siscia mint marks:

$\frac{A|F}{ASIS[C]}$   $\frac{A|F}{ASISCE}$   $\frac{A|F}{S}$   $\frac{A|F}{S}$

1122. Trier mint mark: TRS\*

1123-5. Uncertain mint:  $\frac{OF|I}{S}$   $\frac{OF|II}{S}$  (2).

1126-34. Nine mint marks illegible or cut off.

Cohen 47. 3 Æ.

*Gratian* (367-83 A.D.)

1135-46. *Obv.* D N GRATIANVS AVGG AVG. Bust, diademed and draped, r.

*Rev.* GLORIA NOVI SAECVLI. Gratian standing facing, head turned l., holding labarum and leaning on shield.

1135-41. Arles mint marks:

$\frac{N|}{CON}$  (2),  $\frac{N|}{P CO[N]}$   $\frac{N|}{SCON}$   $\frac{N|}{TCON}$   $\frac{N|}{CON}$   $\frac{N|}{CONST}$

1142-6. Five mint marks illegible or cut off.

Cohen 13. 3 Æ.

1147-55. *Obv.* D N GRATIANVS P F AVG. Bust, diademed and draped, r.

*Rev.* GLORIA ROMANORVM. Type like that of Valentinian I.

1147-53. Lyons mint marks:

$\frac{O|FII}{LVG}$   $\frac{O|FII}{[LVG]}$   $\frac{O|FII}{LVGP}$   $\frac{O|FII}{LVGS}$   $\frac{O|FII}{[LVGS]}$   $\frac{O|FII}{LVGS}$   $\frac{O|FII}{LVGS}$

1154-5. Siscia mint marks:  $\frac{B|F|R}{ASISCP}$   $\frac{B|F|R}{SISC}$

Cohen 16. 3 Æ.



1156. *Obv.* [D N GRATIAN]VS AVGG AVG. Bust, diademed and draped, r.

*Rev.* GLORIA ROMANORVM. Type like that of Valentinian I.

Lyons mint mark: 
$$\frac{\begin{array}{c|c} \text{O} & \text{F II} \\ \hline & \cup \end{array}}{\text{LVGS}}$$

Cohen 24. 3 Æ.

1157. *Obv.* D N GRATIANVS P F AVG. Bust, diademed and draped, r.

*Rev.* REPARATIO REIPVB. Gratian standing l., extends r. hand to kneeling female figure with turreted head-dress; in l. hand he holds victoriola on globe. Mint mark lost.

Cohen 30. 2 Æ. 379-83 A.D.

1158-64. *Obv.* D N GRATIANVS P F AVG. Bust, diademed and draped, r.

*Rev.* SECVRITAS REIPVBLICAE. Type like that of Valentinian I.

1158-60. Arles mint marks:  $\overline{\text{CON}} \quad \overline{\text{SCON}} \quad \overline{\text{TCON}}$

1161. Lyons mint mark: 
$$\frac{\begin{array}{c|c} \text{OF} & \text{II} \\ \hline \text{S} & \end{array}}{\text{LVGP}}$$

1162. Uncertain mint: 
$$\frac{\text{OF} | \text{I}}{\text{////}}$$

1163-4. Two mint marks illegible or cut off.

Cohen 34. 3 Æ.

1165-71. *Obv.* D N GRATIANVS P F AVG. Bust, diademed and draped, r.

*Rev.* Within a laurel wreath: VOT XV MVLT XX.

1165-7. Lyons mint marks:  $\overline{\text{LVGP}} \quad \overline{[\text{L}]\text{VGP}} \quad \overline{\text{LVG}} \text{▨}$

1168. Siscia mint mark:  $\overline{\text{SISC}}$

1169-71. Three mint marks illegible.

Cohen 75. 3 Æ. Q. (*minimi*). c. 380-3 A.D.

*House of Valentinian I (364-83 A.D.)*

Uncertain Attribution (Valentinian I, Valens, or Gratian).

*Obv.* Inscription defective or illegible. Bust, diademed and draped, r.

1172-91. *Rev.* GLORIA ROMANORUM. Type like that of Valentinian I.

1172-4. Arles mint marks:  $\frac{\text{C}}{\text{CON}} \frac{\text{OF}}{\text{CON}*} \frac{\text{O|FII}}{\text{CON}}$   
 $\frac{\text{O|FII}}{\text{S}}$

1175. Lyons mint mark: LVGS

1176-8. Uncertain mint:  $\frac{\text{O|FII}}{\text{S}}$  (3).

1179-91. Thirteen mint marks illegible or cut off.  
 Cf. Cohen, Valentinian I, 12. 3 Æ. and 3 Æ. Q. (cut down).

1192-1217. *Rev.* SECVRITAS REIPVBLICAE. Type like that of Valentinian I.

1192. Aquileia mint mark: SMAQP

1193-4. Arles mint marks:  $\frac{\text{OF|I}}{\text{CO[N]}} \frac{\text{OF|II}}{\text{CONST}}$

1195-8. Lyons mint marks:

$\frac{\text{OF|I}}{\text{LVGP} \cdot \text{LVGP}}$   $\frac{\text{OF|I}}{\text{S|R}}$   $\frac{\text{S}}{\text{S}}$   $\frac{\text{S}}{\text{S}}$

1199. Thessalonica mint mark:  $\frac{\text{TES}}{\text{TES}}$

1200-2. Uncertain mint:  $\frac{\text{OF|I}}{\text{S}}$  (2),  $\frac{\text{T}}{\text{S}}$

1203-17. Fifteen mint marks illegible or cut off.  
 Cf. Cohen, Valentinian I, 37. 3 Æ.

*Magnus Maximus* (383-8 A. D.)

*Obv.* in all cases: D N MAG MAXIMVS P F AVG. Bust, diademed and draped, r.



1218. *Rev.* REPARATIO REIPVB. Emperor standing l., extends r. hand to kneeling female figure with turreted head-dress, and holds in l. hand a victoriola which holds out a wreath towards his head.

Mint mark, TCON Arles.

Cohen 3. 2 Æ.

1219-38. *Rev.* SPES ROMANORVM. Gate of praetorian camp surmounted by two turrets; between them, a star.

1219-22. Aquileia mint marks:

AQ·P MAQP SMAQP SMAQS

1223-30. Arles mint marks:

PCON (3), SCON (2), TCON (3).

1231-2. Lyons mint mark: LVGS (2).

1233-8. Six mint marks illegible or cut off.

Cohen 7. 3 Æ. Q.

1239. *Rev.* Within a laurel wreath: VOTIS V.

Mint mark illegible.

Cohen 22. 3 Æ. Q.

1240. *Rev.* Within a laurel wreath: VOT V MVLX.

Mint mark: LVGS Lyons.

Cohen 24. 3 Æ. Q.


*Flavius Victor* (383-8 A.D.)


1241-51. *Obv.* D N FL VICTOR P F AVG. Bust, diademed and draped, r.

*Rev.* SPES ROMANORVM. Type like that of Magnus Maximus.

1241-2. Aquileia mint marks: SMAQP (2).

1243. Arles           ,, mark: PCON

1244-6. Lyons           ,, marks: LVG LVGP (2).

1247. Rome           ,, mark: SMR

1248-9. Trier           ,, marks: SMTR (2).

1250-1. Two illegible mint marks.

Cohen 3. 3 Æ. Q.

Uncertain Attribution

Magnus Maximus or Flavius Victor (383-8 A.D.)

1252-6. *Obv.* Inscription defective or illegible. Bust, diademed and draped, r.

*Rev.* SPES ROMANORVM. Type like that of Magnus Maximus.

Five illegible mint marks.

Cf. Cohen, Magnus Maximus, 7. 3 Æ. Q.

*House of Theodosius I (379-95 A.D.)*

1258. *Rev.* GLORIA REIPUBLICAE. Gateway of praetorian camp, surmounted by two towers.  
*Obv.* D N ARCADIVS P F AVG. Youthful portrait, diademed and draped, r.  
 Trier mint mark:  $\overline{\text{TRS}}$   
 Sabatier 34. Cf. Cohen, Valentinian II, 12. 3 Æ. Q.  
 c. 383-8 A.D.
1259. *Rev.* GLORIA ROMANORVM (inscribed backwards on l. side). Emperor advancing r., holding labarum in r. hand, and dragging kneeling captive by the hair with l.  
*Obv.* Illegible.  
 Mint mark lost (if any).  
 Barbarous imitation of Cohen, Theodosius I, 23. 3 Æ. Q.
- 1260-2. *Rev.* REPARATIO REIPVB. Type like that of Magnus Maximus (no. 1218). 2 Æ.
1260. *Obv.* D N VALENTINIANVS P F AVG. Bust, diademed and draped, r.  
 Arles mint mark:  $\overline{\text{SCON}}$   
 Cohen, Valentinian II, 28. 379-92 A.D.
- 1261-2. *Obv.* Illegible.  
 Two mint marks lost (coins fragmentary).
- 1263-1650. *Rev.* SALVS REIPUBLICAE. Victory advancing l., head turned r., holds trophy over r. shoulder and drags kneeling captive by the hair. 3 Æ. Q.
- 1263-98. *Obv.* D N THEODOSIVS P F AVG. Bust, diademed and draped, r.  
 1263-70. Mint marks:
- |         |                                     |                                     |   |
|---------|-------------------------------------|-------------------------------------|---|
|         | $\frac{\text{f} }{\text{AQP}}$ (5), | $\frac{\text{f} }{\text{AQS}}$ (2), | $\frac{\text{f} }{\text{AQ}}$ Aquileia. |
| 1271.   | $\frac{\text{f} }{\text{LVC}}$      |                                     | Lyons.                                  |
| 1272-3. | $\frac{\text{f} }{\text{R:P}}$      | $\frac{\text{f} }{\text{R}}$        | Rome.                                   |
| 1274.   | $\frac{\text{f} }{\text{TRP}}$      |                                     | Trier.                                  |

1275-89.  $\frac{\text{P}|\text{I}}{\text{///}} (15)$ . Uncertain mint.

1290-8. And nine illegible.

Cohen 30. 390-5 A. D.

1299-1325. *Obv.* D N VALENTINIANVS P F AVG. Bust, as above.

1299-1303. Mint marks:

$\frac{\text{P}|\text{I}}{\text{AQP}} (3)$ ,  $\frac{\text{P}|\text{I}}{\text{AQS}} (2)$ . Aquileia.

1304-8.  $\frac{\text{P}|\text{I}}{\text{RP}}$   $\frac{\text{P}|\text{I}}{\text{R}\cdot\text{P}}$  (3),  $\frac{\text{P}|\text{I}}{\text{R}\ddagger\text{P}}$  Rome.

1309-25.  $\frac{\text{P}|\text{I}}{\text{///}} (17)$ . Uncertain mint.

Cohen 33. 390-2 A. D.

1326-55. *Obv.* DN ARCADIVS P F AVG. Bust, as above.

1326. Mint marks:  $\frac{\text{P}|\text{I}}{\text{ANT} \text{///}}$  Antioch.

1327-30.  $\frac{\text{P}|\text{I}}{\text{AQP}}$   $\frac{\text{P}|\text{I}}{\text{AQS}} (3)$ . Aquileia.

1331.  $\frac{\text{P}|\text{I}}{\text{///CON}}$  Arles.

1332.  $\frac{\text{P}|\text{I}}{\text{LVGS}}$  Lyons.

1333-4.  $\frac{\text{P}|\text{I}}{\text{RS}} (2)$ . Rome.

1335-54.  $\frac{\text{P}|\text{I}}{\text{///S}}$   $\frac{\text{P}|\text{I}}{\text{///}} (19)$ . Uncertain mint.

1355.

And one illegible.

Sabatier 41. 390-5 A. D.

1356-68. *Obv.* DN HONORIVS P F AVG. Bust, as above.

1356. Mint marks:  $\frac{\text{P}|\text{I}}{\text{AQP}}$  Aquileia.

1357-8.  $\frac{\text{P}|\text{I}}{\text{RP}}$   $\frac{\text{P}|\text{I}}{\text{R}\cdot\text{P}}$  Rome.

1359-67.  $\frac{\text{P}|\text{I}}{\text{///}} (9)$ . Uncertain mint.

1368.

And one illegible.

Cohen 32. 393-5 A. D.

1369-76. *Obv.* D N ONORIVS P F AVG. Bust, as above.

1369-75. Mint mark,  $\frac{\text{P}|\text{I}}{\text{|||||}}$  (7). Uncertain mint.

1376.

And one illegible.

Variant not in Cohen. Same date.

#### Uncertain Attribution

(Theodosius I, Valentinian II, Arcadius, or Honorius)

1377-1650. *Obv.* Incomplete or illegible.

1377. Mint marks:  $\frac{\text{P}|\text{I}}{\text{ALE}\Gamma}$  Alexandria.

1378-1401.

$\frac{\text{P}|\text{I}}{\text{AQP}}$  (5),  $\frac{\text{P}}{\text{AQP}\cdot}$  (3),  $\frac{\text{P}|\text{I}}{\text{AQS}}$  (4),  $\frac{\text{P}|\text{I}}{\text{AQ}\cdot\text{S}}$  (2),

$\frac{|\text{I}}{\text{AQS}}$   $\frac{\check{\text{I}}|\text{I}}{\text{AQS}}$  (2),  $\frac{\text{P}|\text{I}}{\text{AQ}\text{||||}}$  (5),  $\frac{\text{P}|\text{I}}{\text{AQ}\cdot\text{||||}}$  (2).

Aquileia.

1402.  $\frac{\text{P}|\text{I}}{\text{TCO}\text{||||}}$  Arles.

1403.  $\frac{\text{CONS}}{\text{_____}}$  Constantinople.

1404.  $\frac{\text{LVGP}}{\text{_____}}$  Lyons.

1405-16.  $\frac{\text{P}|\text{I}}{\text{R P}}$  (2),  $\frac{\text{_____}}{\text{R P}}$  (2),  $\frac{\text{P}|\text{I}}{\text{R}\Omega\text{P}}$  (2),  $\frac{\cdot}{\text{R}\Omega\text{P}}$  (2),

$\frac{\text{P}|\text{I}}{\text{||||}\wedge\text{P}}$   $\frac{\text{_____}}{\text{R T}}$   $\frac{\text{_____}}{\text{R}\cdot\text{T}}$   $\frac{\text{P}|\text{I}}{\text{R}\text{||||}}$  Rome.

1417.  $\frac{\text{T}\cdot\text{C}}{\text{_____}}$  Ticinum.

1418.  $\frac{\text{TRS}}{\text{_____}}$  Trier.

1419.  $\frac{\text{P}|\text{I}}{\text{||||}\text{P}}$  Uncertain.

1420-1625.  $\frac{\text{P}|\text{I}}{\text{|||||}}$  Uncertain mint.

1626-50. And twenty-five illegible; at least six are barbarous, including two half quinarii.  
390-5 A.D.

1651-2410. *Rev.* VICTORIA AVGGG. Victory advancing l. with wreath and palm branch. 3 Æ. Q.

168 REPORTS OF THE SOCIETY OF ANTIQUARIES

1651-1724. *Obv.* D N THEODOSIVS P F AVG. Bust, diademed and draped, r.

1651-78. Mint marks:  
 $\overline{\text{SCON}}$  (15),  $\overline{\text{TCON}}$  (8),  $\overline{\text{CON}}$  (5). Arles.

1679-85.  $\overline{\text{LVGP}}$  (3),  $\overline{\text{LVGP} \cdot \text{LVGS LVG}}$  (2). Lyons.

1686.  $\overline{\text{R} \cdot \text{P}}$  Rome.

1687-1724. Thirty-eight illegible, including at least three local imitations.

Cohen 41. 388-95 A. D.

1725-89. *Obv.* D N VALENTINIANVS P F AVG. Bust, as above.

1725-47. Mint marks:  
 $\overline{\text{PCON}}$  (15),  $\overline{\text{P} \cdot \text{CON}}$  (2),  $\overline{\text{TCON}}$   $\overline{\text{CON}}$  (5).  
 Arles.

1748-59.  $\overline{\text{LVGP}}$  (7),  $\overline{\text{LVGP} \cdot \text{P}}$  (2),  $\overline{\text{LVGP} \cdot \text{LVG}}$   $\overline{\text{CON}}$  (2).  
 Lyons.

1760.  $\overline{\text{TRS}}$  Trier.

1761-89. Twenty-nine illegible.

Cohen 46. 388-92 A. D.

1790-1933. *Obv.* D N ARCADIVS P F AVG. Bust, as above.

1790-1832. Mint marks:  
 $\overline{\text{PCON}}$  (8),  $\overline{\text{TCON}}$  (24),  $\overline{\text{CON}}$  (18),  $\overline{\text{CON}}$  (3).  
 Arles.

1833-46.  $\overline{\text{LVGP}}$  (11)  $\overline{\text{LVG}}$   $\overline{\text{LVG}}$  (2). Lyons.

1847.  $\overline{\text{T R}}$  (Probably) Trier.

1848-1933. Eighty-six illegible, including at least one local imitation and one half-quinarius.

Cf. Sabatier 26 (*siliqua*). 388-95 A. D.

1934-56. *Obv.* D N HONORIVS P F AVG. Bust, as above.

1934-6. Mint marks:  $\overline{\text{SCON}}$   $\overline{\text{TCON}}$   $\overline{\text{CON}}$  Arles.

1937.  $\overline{\text{L} \cdot \text{P}}$  Lyons.

1938-56. And nineteen illegible.

Cohen 39. 393-5 A. D.

1957. *Obv.* [D N] HONRIVS P F AVG. Bust, as above.  
 One illegible mint mark.

1958-9. *Obv.* D N ONORIVS P F AVG. Bust, as above.  
 Two illegible mint marks.

1960-2410. *Obv.* Incomplete or illegible. Bust, as above.

1960-2004. Mint marks:

$\overline{\text{PCON}}$  (8),  $\overline{\text{P}\cdot\text{CON}}$   $\overline{\text{SCON}}$  (5),  $\overline{\text{TCON}}$  (14),  
 $\overline{\text{CON}}$  (13),  $\overline{\text{ON}}$  (4). Arles.

2005-33.  $\overline{\text{LVGP}}$  (15),  $\overline{\text{LVG}\cdot\text{P}}$   $\overline{\text{LVGP}}$   $\overline{\text{GP}}$  (2),  
 $\overline{\text{LVG}}$  (7),  $\overline{\text{LVG}}$  (2). Lyons.

2034-7.  $\overline{\text{R P}}$  (2),  $\overline{\text{R}}$  (2),  $\overline{\text{P}}$  (2). Rome.

2038.  $\overline{\text{TP}}$  Ticinum.

2039-45.  $\overline{\text{TRP}}$  (2),  $\overline{\text{T RP}}$   $\overline{\text{TR}}$  (2),  $\overline{\text{R}}$  (2). Trier.

2046.  $\overline{\text{L}}$  Uncertain mint.

2047-2410. And 364 illegible, including many local imitations, two of which bear 'mint marks'  
 $\overline{\text{NOO NOC}}$ ; a blundered imitation of  $\overline{\text{CON}}$   
 (Arles).

388-95 A.D.

2411-33. *Rev.* VICTORIA AVGGG. Two Victories facing, each holding wreath and palm branch. 3 Æ. Q. 388-92 A.D.

2411-17. *Obv.* D N THEODOSIVS P F AVG. Bust, diademed and draped, r.

2411-15. Mint marks:

$\overline{\text{R}\cdot\text{P}}$   $\overline{\text{R}\cdot\text{T}}$   $\overline{\text{RT}}$   $\overline{\text{R}\cdot\text{Q}}$  (2). Rome.

2416-17. Two illegible.  
 Cohen 43.

2418-23. *Obv.* D N VALENTINIANVS P F AVG. Bust, as above.

2418. Mint marks:  $\overline{\text{SMN}\Gamma}$  Nicomedia.

2419-22.  $\overline{\text{R}\Omega[\text{P}]}$   $\overline{\text{R T}}$   $\overline{\text{R}\epsilon}$  (or s)  $\overline{\text{R}}$  Rome.

2423. One illegible.

Not in Cohen.

2424-33. *Obv.* Illegible. Bust, as above.



- 2424-9. Mint marks:  $\frac{\cdot}{\text{R}\cdot}$   $\frac{\cdot}{\text{R}\cdot}$  (5). Rome.
- 2430-3. Four illegible.
- 2434-9. *Rev.* VIRTVS ROMANORVM. Roma, helmeted, seated on a cuirass, l., holding victoriola on globe and inverted spear. *R.* (*Siliquae*)
2434. *Obv.* D N ARCADIVS P F AVG.  
Trier mint mark:  $\overline{\text{TRPS}}$ .  
Sabatier 27.
2435. *Obv.* D N HONORIVS P F AVG. Youthful portrait.  
Milan mint mark:  $\overline{\text{MDPS}}$ .  
Cohen 59.
- 2436-7. *Obv.* Illegible.  
Two mint marks lost (coins cut down).  
*Rev.* Within a laurel wreath: VOT V. 3  $\text{Æ}$ . Q.
- 2438-9. *Obv.* D N ARCADIVS P F AVG. Youthful portraits.  
2438. Mint marks: Kyzicus,  $\overline{\text{SMK}\Delta}$ .  
2439. Lyons,  $\overline{\text{LVG}}$ .  
Sabatier 47. Cf. Cohen, Theodosius I, 63.
2440. *Rev.* Within a laurel wreath: VOT V MVL T X. *R.*  
(*Siliqua*)  
*Obv.* D N HONORIVS P F AVG.  
Milan mint mark:  $\overline{\text{MDPS}}$ .  
Cohen 63.
2441. *Rev.* Within a laurel wreath: VOT X MVL T XV. *R.*  
(*Siliqua*)  
*Obv.* D N ARCADIVS P F AVG.  
Milan mint mark:  $\overline{\text{MDPS}}$ .  
Sabatier 28.
- 2442-50. *Rev.* Within a laurel wreath: VOT X MVL T XX. 3  $\text{Æ}$ . Q.
- 2442-4. *Obv.* D N THEODOSIVS P F AVG.  
2442. Mint marks: Kyzicus,  $\overline{\text{SMKR}}$ .  
2443. Rome,  $\overline{\text{SMRP}}$ .  
2444. Trier,  $\overline{\text{TRP}}$ .  
Cohen 68.

- 2445-50. *Obv.* Illegible.  
 2445. Uncertain mint mark, SM///////.  
 2446-50. Five illegible mint marks.  
 Date : probably the decennalia of Valentinian II, 385 A.D.
- 2451-8. *Rev.* Within a laurel wreath : VOT XV MVL T XX.  
 3 Æ. Q.
2451. *Obv.* D N THEODOSIVS P F AVG.  
 Aquileia mint mark : SMAQP.  
 Not in Cohen.
- 2452-3. *Obv.* D N VALENTINIANVS P F AVG.  
 2452. Mint marks : Aquileia, SMAQ////.  
 2453. Rome, SMRE.  
 Variant of Cohen 74.
- 2454-8. *Obv.* Illegible.  
 Five illegible mint marks.
- 2459-60. *Rev.* Within a laurel wreath : VOT XX MVL T XXX.  
 3 Æ. Q.  
*Obv.* Illegible.  
 2459. Nicomedia mint mark : SMNA.  
 2460. One illegible mint mark.  
 Cf. Cohen, Valentinian II, 75.
2461. *Rev.* Within a laurel wreath : VOT//// MVL T////. 3 Æ. Q.  
*Obv.* D N THEODOSIVS P F AVG.  
 One illegible mint mark.
- 2462-3. *Rev.* VRBS ROMA. Roma, helmeted, seated l. on trophy, holding victoriola on globe and vertical sceptre. Æ. (*Siliquae*)  
 2462. *Obv.* D N THEODOSIVS P F AVG.  
 Trier mint mark : T•RPS.  
 Cohen 72.
2463. *Obv.* Illegible.  
 One mint mark lost (coin cut down).  
*Reverses* obliterated. 3 Æ. Q.
- 2464-6. *Obv.* D N THEODOSIVS P F AVG. Three.
- 2467-9. *Obv.* D N VALENTINIANVS P F AVG. Three.
- 2470-81. *Obv.* D N ARCADIVS P F AVG.  
 2470. Mint marks : Arles, CON.  
 2471. Lyons, LVG.  
 2472-81. Ten illegible mint marks.


2482-4. *Obv.* D N HONORIVS P F AVG. Three.

2485-6. *Obv.* D N ONORIVS P F AVG. Two.

*Eugenius* (392-4 A. D.)

*Obverse* in all cases : D N EVGENIVS P F AVG. Bust, diademed and draped, r. 3 Æ. Q.

2487-8. *Rev.* SPES ROMA[NORVM]. Victory advancing l., with wreath and palm branch.

2487. Mint mark, AQ  Aquileia.

2488. One illegible.

Cohen 5.

2489. *Rev.* VICTORIA AVGG. Same device.

Mint mark illegible.

Cohen 8.

2490. *Rev.* VIRTVS EXERCITVS. Same device.

Mint mark illegible.

Cohen 15.

Uncertain Attribution. Late Fourth Century

Local Imitation

2491. *Obv.* Illegible. Rough bust, diademed or laureate and draped, r.

*Rev.* Sort of grille, consisting of four upright and two cross-bars. Above, R†.

Possibly, an imitation of Magnus Maximus, *Rev.* SPES ROMANORVM, with praetorian gateway (383-8 A. D.).

Cf. Cohen, Magnus Maximus, 7. 3 Æ. Q.

**Post-Roman**

*Saxon Sceatta*

*Obv.* Within a border of pellets and a plain circle, two figures, standing, facing, each holding a sceptre with cross; between their shoulders a cross.

*Rev.* Similar border. Dragonisque animal l., head turned r., body outline bordered with pellets. Silver. Seventh to early eighth century A. D.

Cf. B. M. C., *Anglo-Saxon Coins*, p. 19, nos. 173-9.

*Philip II of Spain* (1556–98 A.D.)*Obv.* HIPANOR REX. Crowned bust, r.*Rev.* Within a laurel wreath: four briquets alternating with four sparks; in centre, jewel of the Order of the Golden Fleece.

So-called mite, struck in Brabant.

## RECKONING COUNTERS OR JETTONS

One French. Fifteenth century.

One German. Early sixteenth century.

## TRADESMAN'S TOKEN

Small copper, slightly cupped.

Concave side: WILLIAM KEYLOCKE. In centre

Convex side: IN · DOVER · 1667. In centre <sup>×K×</sup>  
WM



PLATES

PLATE I



Fig. 1. North wall of Fort, p. 3



Fig. 2. South side of West Gate, p. 30

PLATE II



Fig. 1. General view of Site I, looking west, p. 14



Fig. 2. Site I. North end of courtyard, looking north-west  
A. furnace, p. 13; B. tank, p. 16; C. north wall of 6, p. 16

*Published by the Society of Antiquaries of London, 1926*





Fig. 1. Site I, east side, looking south-west: A, A, earlier foundations, pp. 12, 15



Fig. 2. Front of Site I, looking west: A. early foundations, p. 12; B. front work of Site I; c. supposed portico wall, p. 17

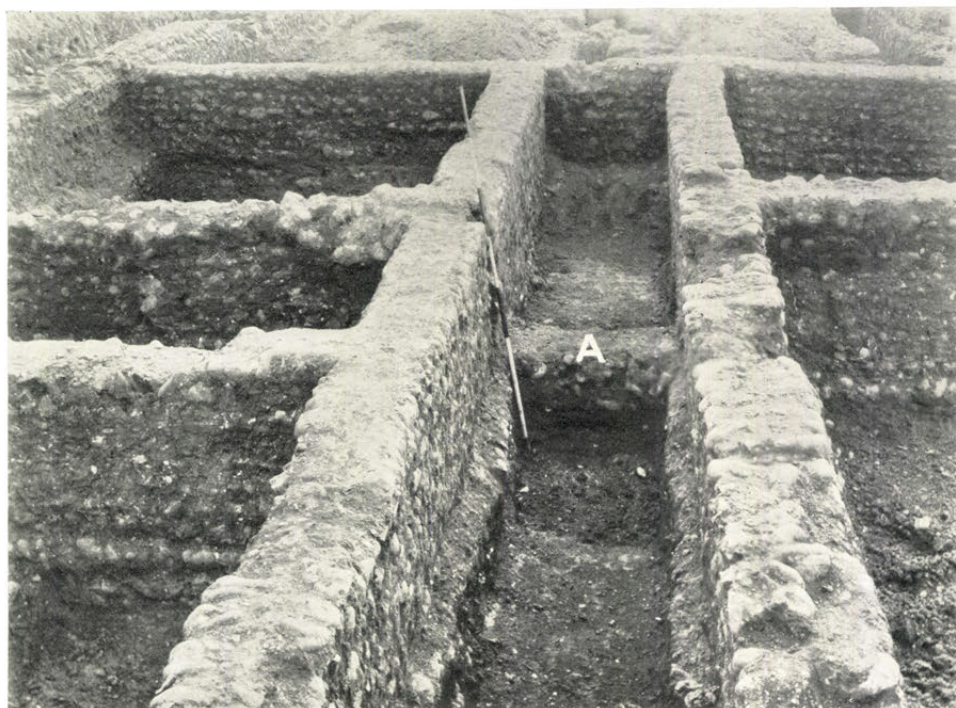


Fig. 1. Site I, corridor: A. clay and cobble foundations, p. 15



Fig. 2. Site of south postern turret, p. 33  
A. broken end of main wall; B. fallen masonry

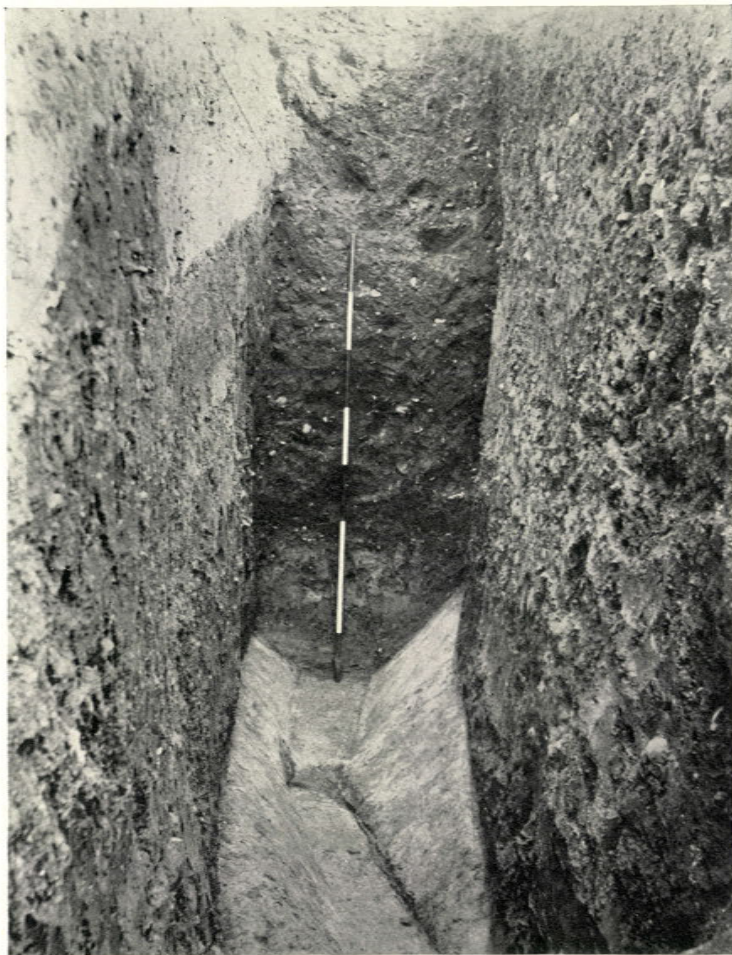


Fig. 1. Cut following line of ditch, p. 11



Fig. 2. Site I. Remains of dividing wall between rooms 7 and 8, and 9 and 10, looking south, p. 10



Fig. 1. Site I. Brick piers on west side of room 8, p. 16



Fig. 2. Face of north wall of fort, p. 20



Fig. 1. Site II. Hexagonal structure, p. 19



Fig. 2. Site I. Inscribed marble slab forming bottom of tank, p. 18



Fig. 1. Fragments of marble casing (x, x) in west wall of fort, p. 36



Fig. 2. West wall of fort showing method of pointing, p. 34



PLATE IX

Sculptured slab, back, front, and side views, p. 37



Fig. 1. Relief from Boulogne, p. 38

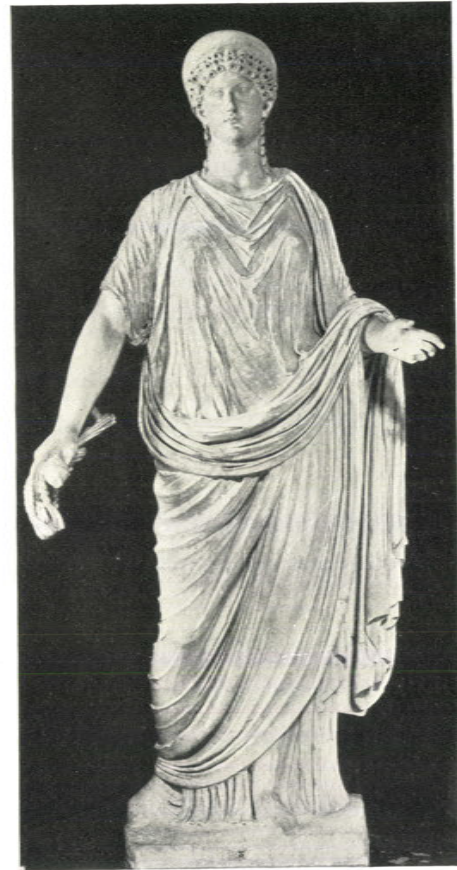
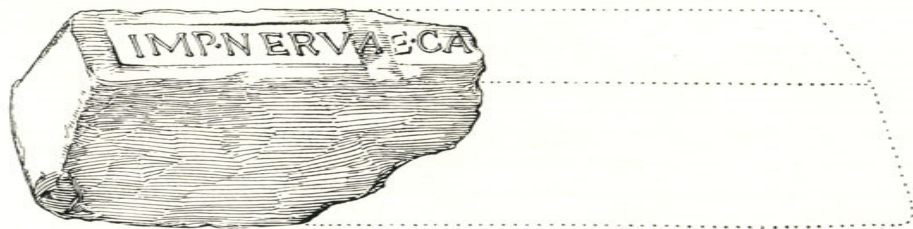


Fig. 2. Statue of a Roman Empress as  
Abundantia, p. 39

*Published by the Society of Antiquaries of London, 1926*

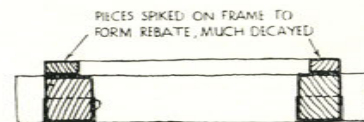




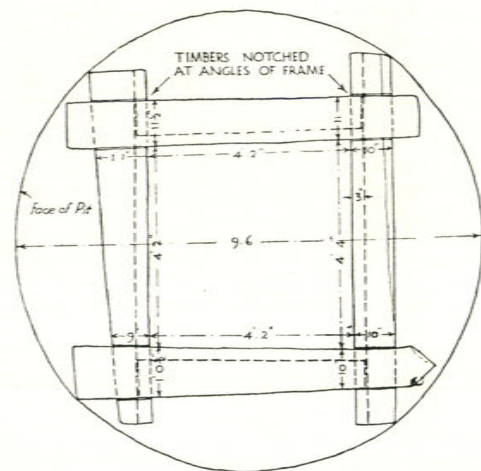
Pig of lead ( $\frac{1}{6}$ ), p. 42



Inscription on pig of lead, from a squeeze ( $\frac{1}{3}$ )



SECTION

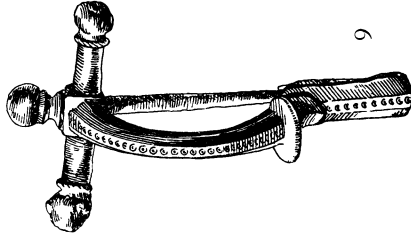
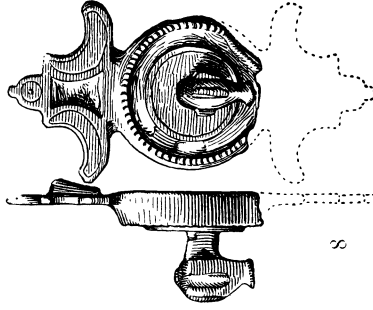
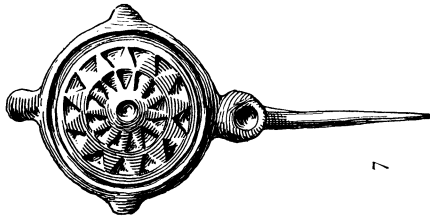
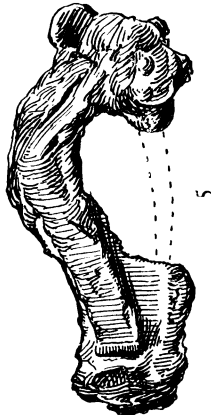
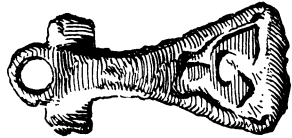
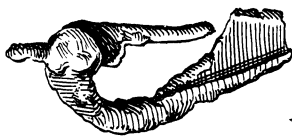
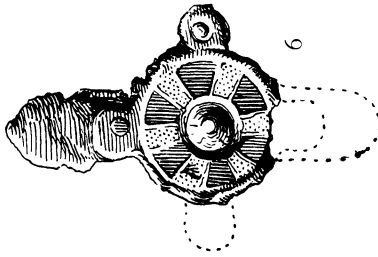
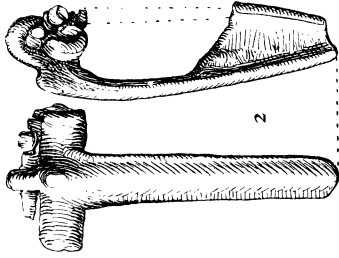
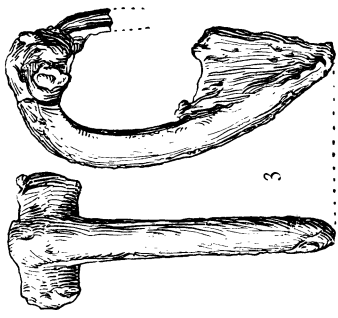


PLAN

Scale of 1 0 1 2 3 4 5 Feet

Timbering at bottom of Pit 7, p. 22

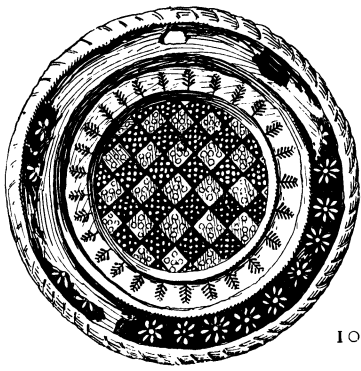
PLATE XII



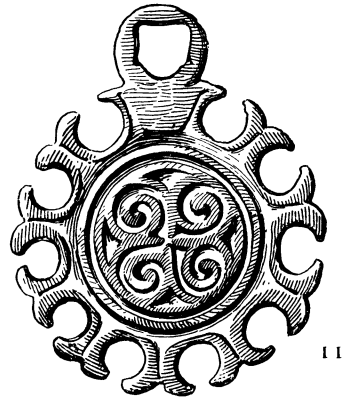
Brooches (1), pp. 42-4

Published by the Society of Antiquaries of London, 1926

PLATE XIII



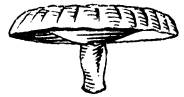
10



11



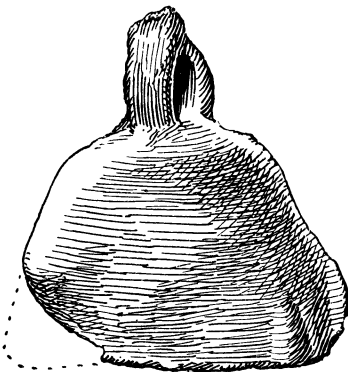
12



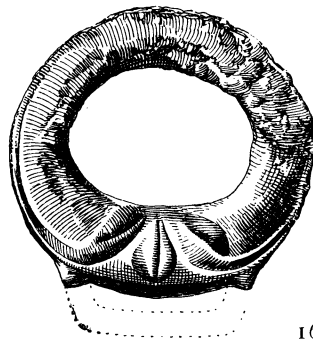
13



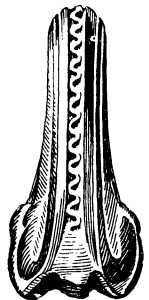
14



15



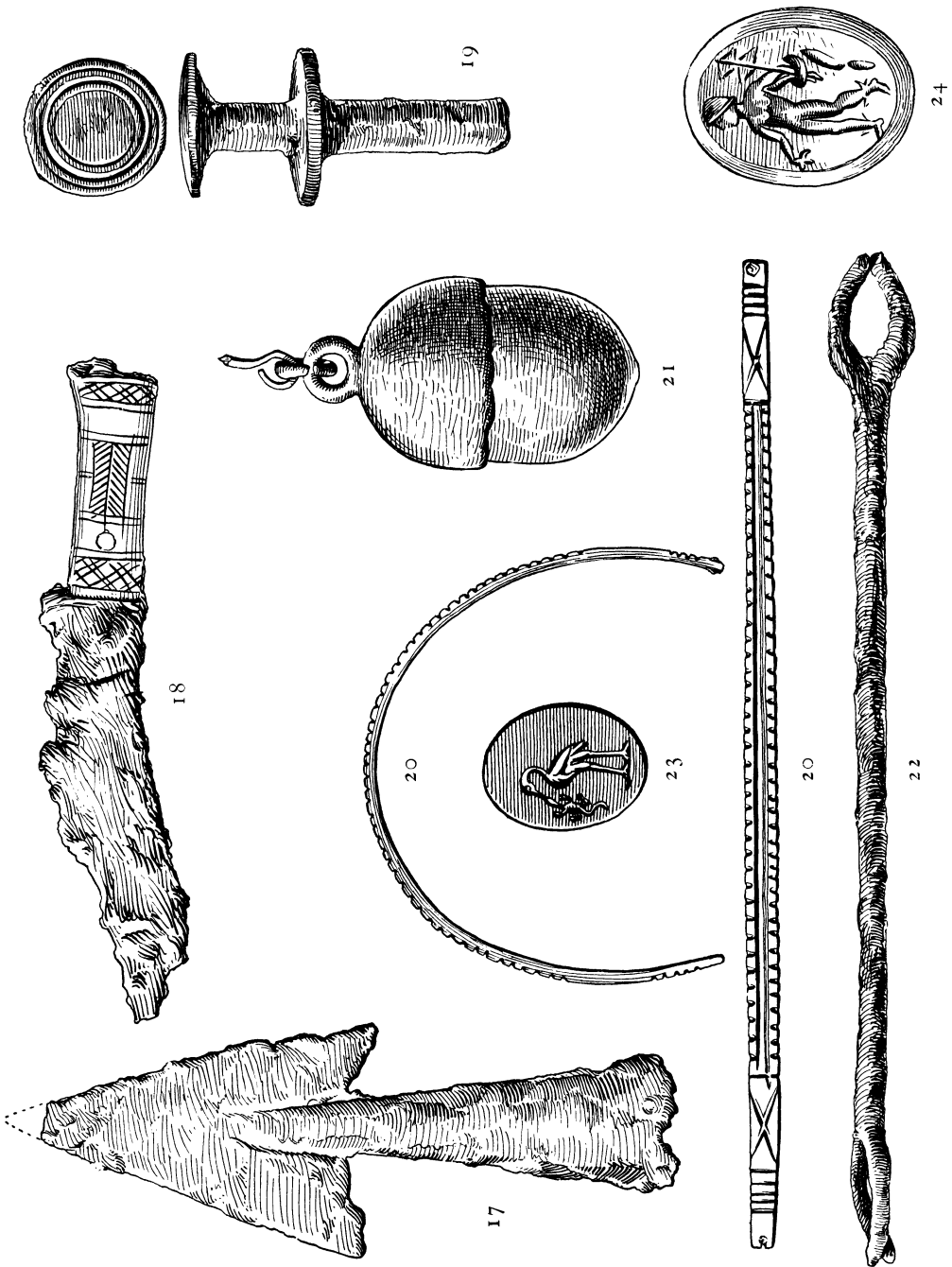
16



Various small objects ( $\frac{1}{2}$ ), pp. 44-5

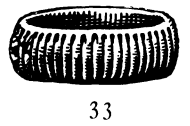
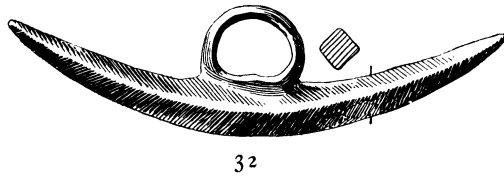
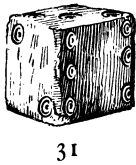
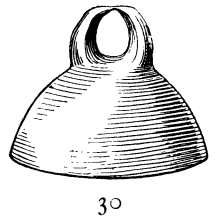
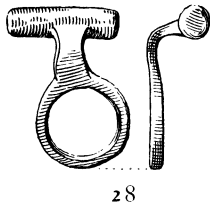
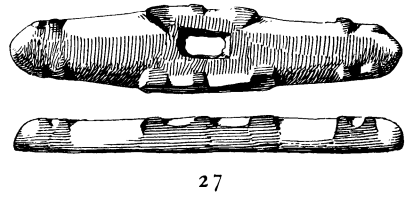
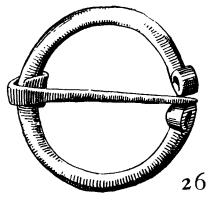
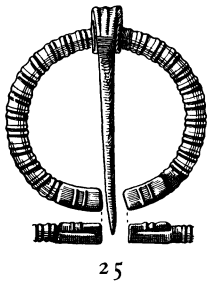
*Published by the Society of Antiquaries of London, 1926*

PLATE XIV



Various small objects ( $\frac{1}{4}$ ; 23, 24,  $\frac{2}{4}$ ), pp. 45-6

*Published by the Society of Antiquaries of London, 1926*

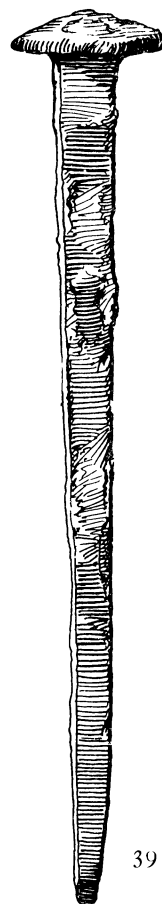
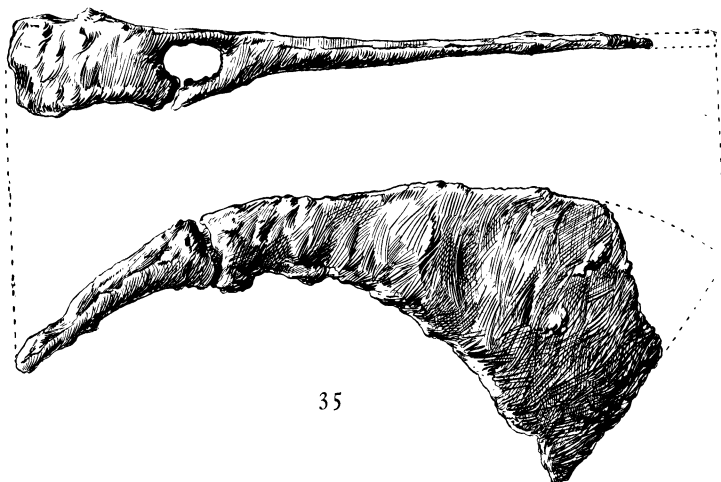


34

Various small objects ( $\frac{1}{2}$ ; 34,  $\frac{3}{4}$ ), pp. 46-7

*Published by the Society of Antiquaries of London, 1926*

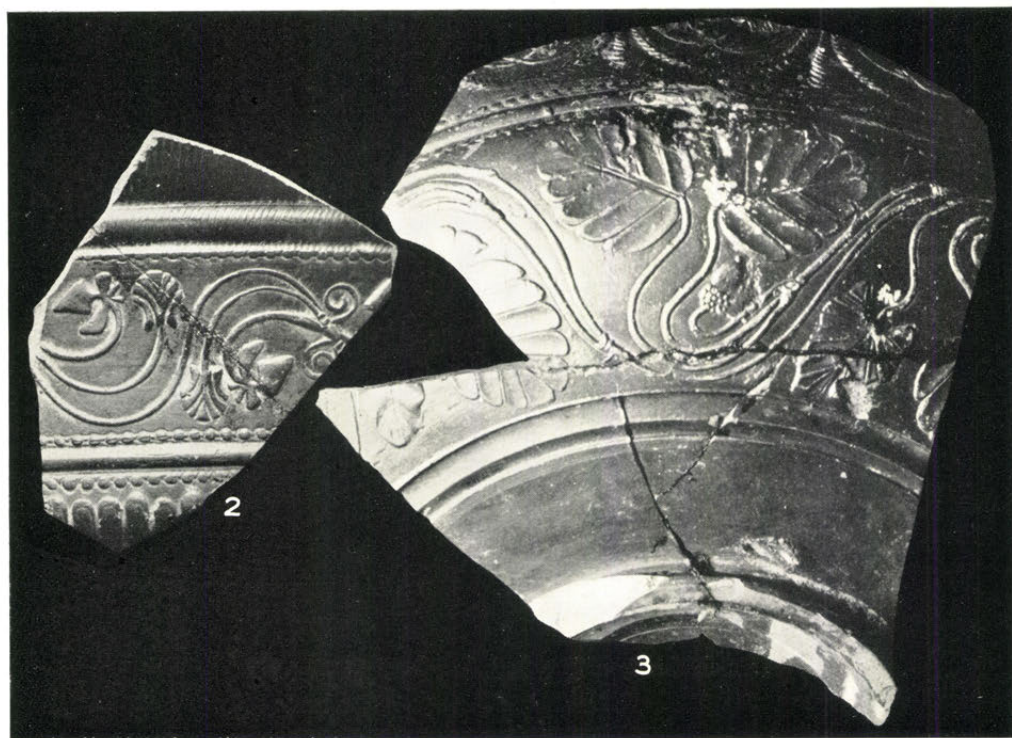
PLATE XVI



Iron and bronze objects (35,  $\frac{1}{4}$ , 36-39,  $\frac{1}{1}$ ), pp. 47-8

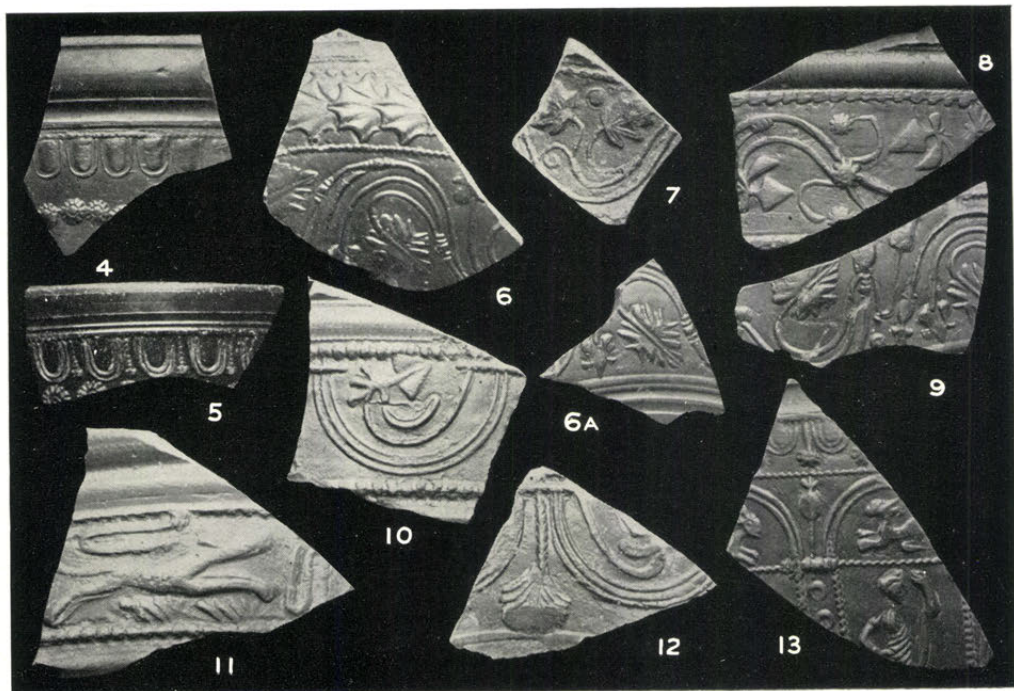


Decorated Samian ( $\frac{3}{4}$ ), p. 50

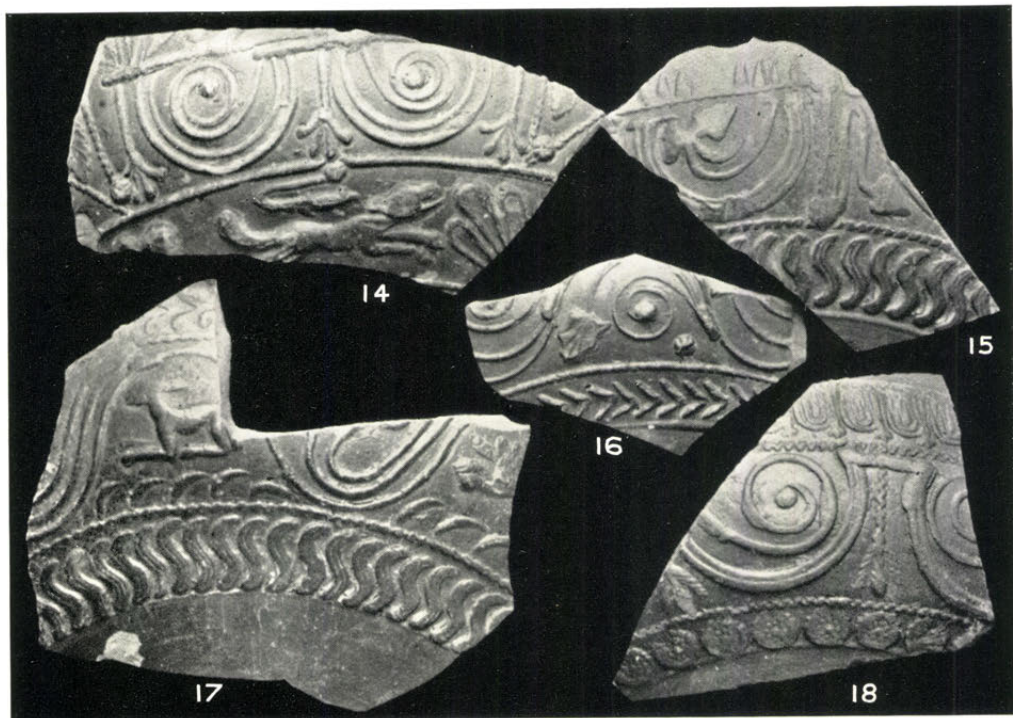


Decorated Samian ( $\frac{3}{4}$ ), p. 50

PLATE XVIII



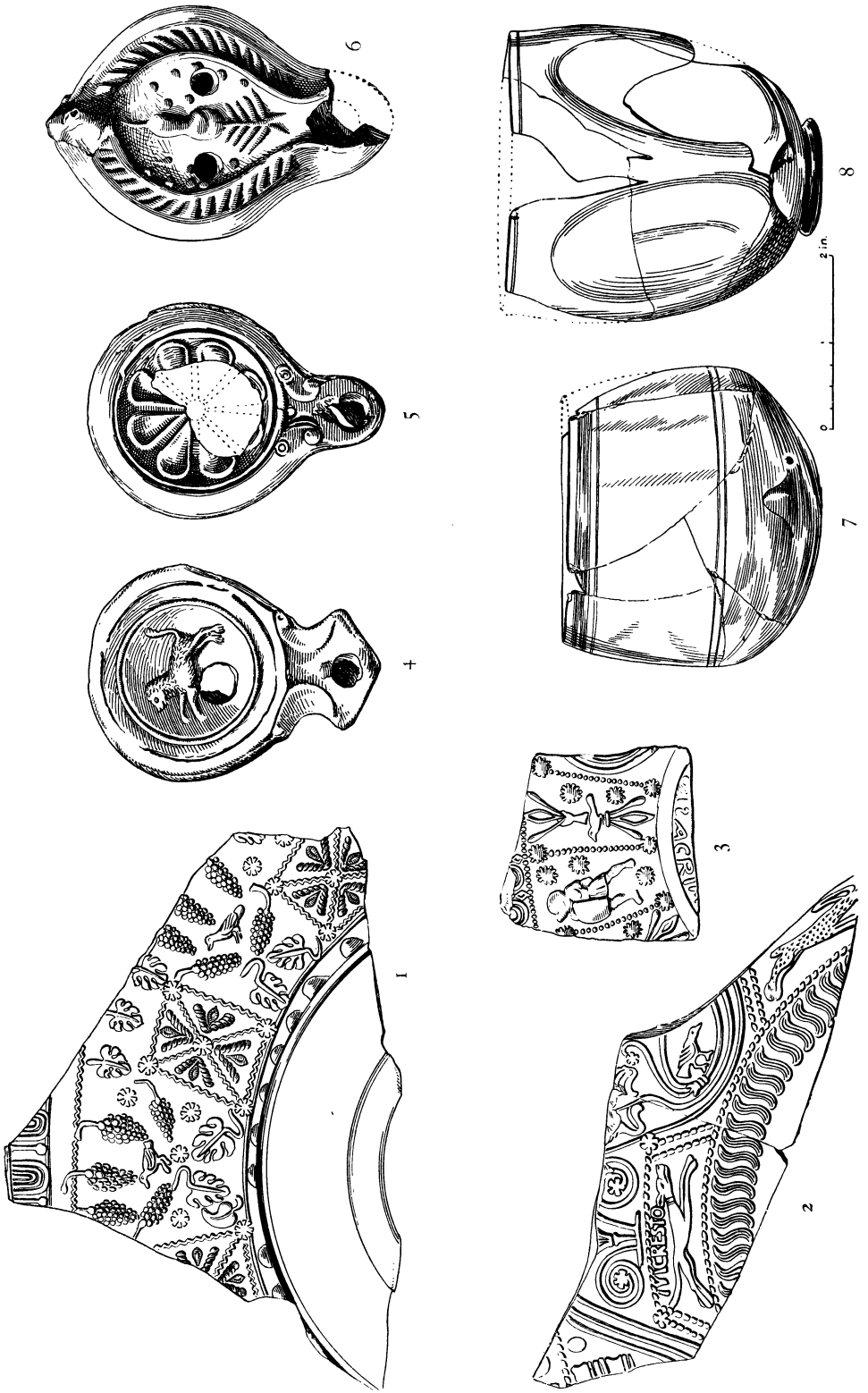
Decorated Samian ( $\frac{3}{4}$ ), pp. 51-2



Decorated Samian ( $\frac{2}{3}$ ), pp. 53-4

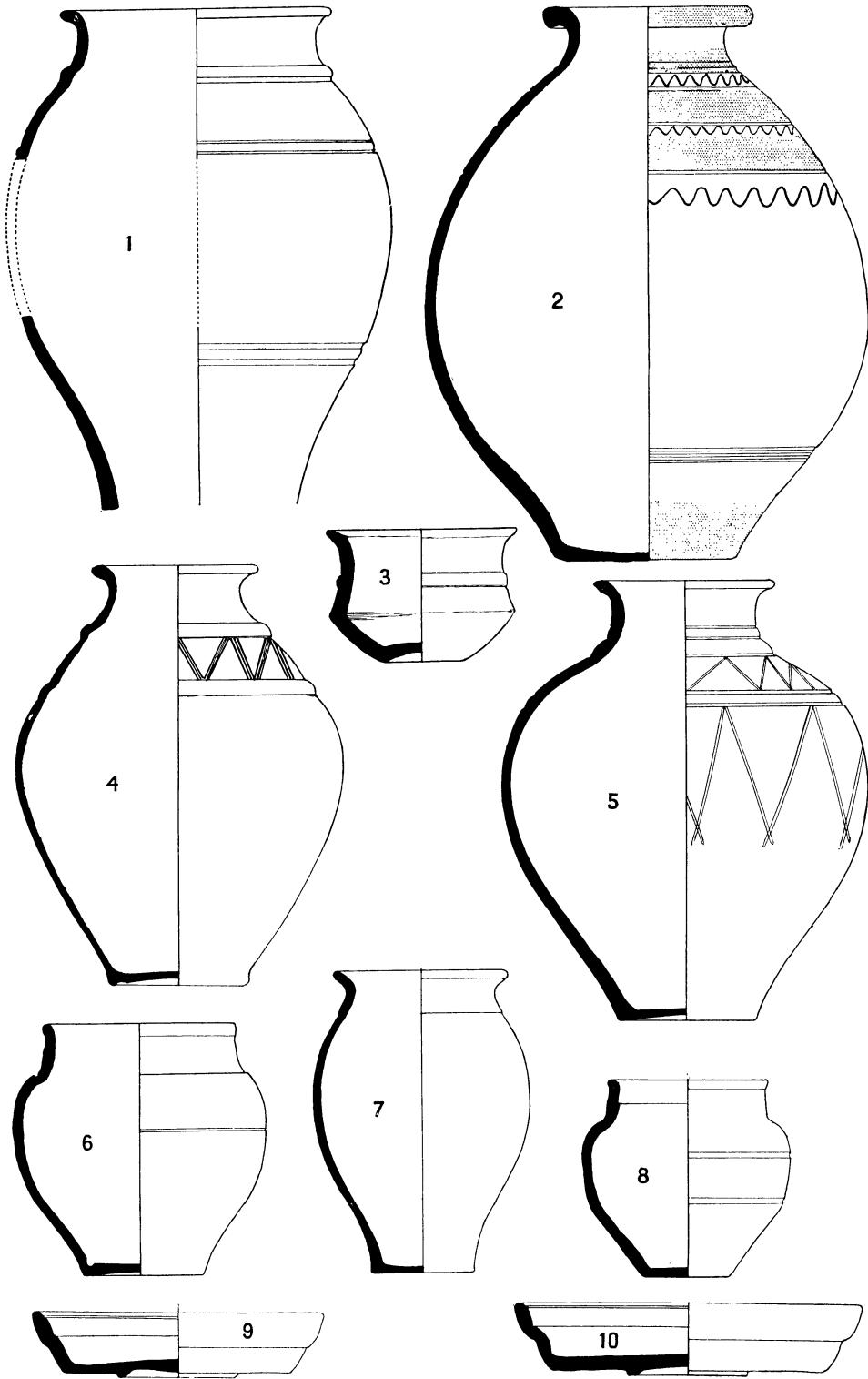


PLATE XIX



Decorated Samian ( $\frac{1}{2}$ ), pp. 54-5, 60; lamps ( $\frac{1}{2}$ ), p. 48; and glass ( $\frac{1}{2}$ ), p. 48

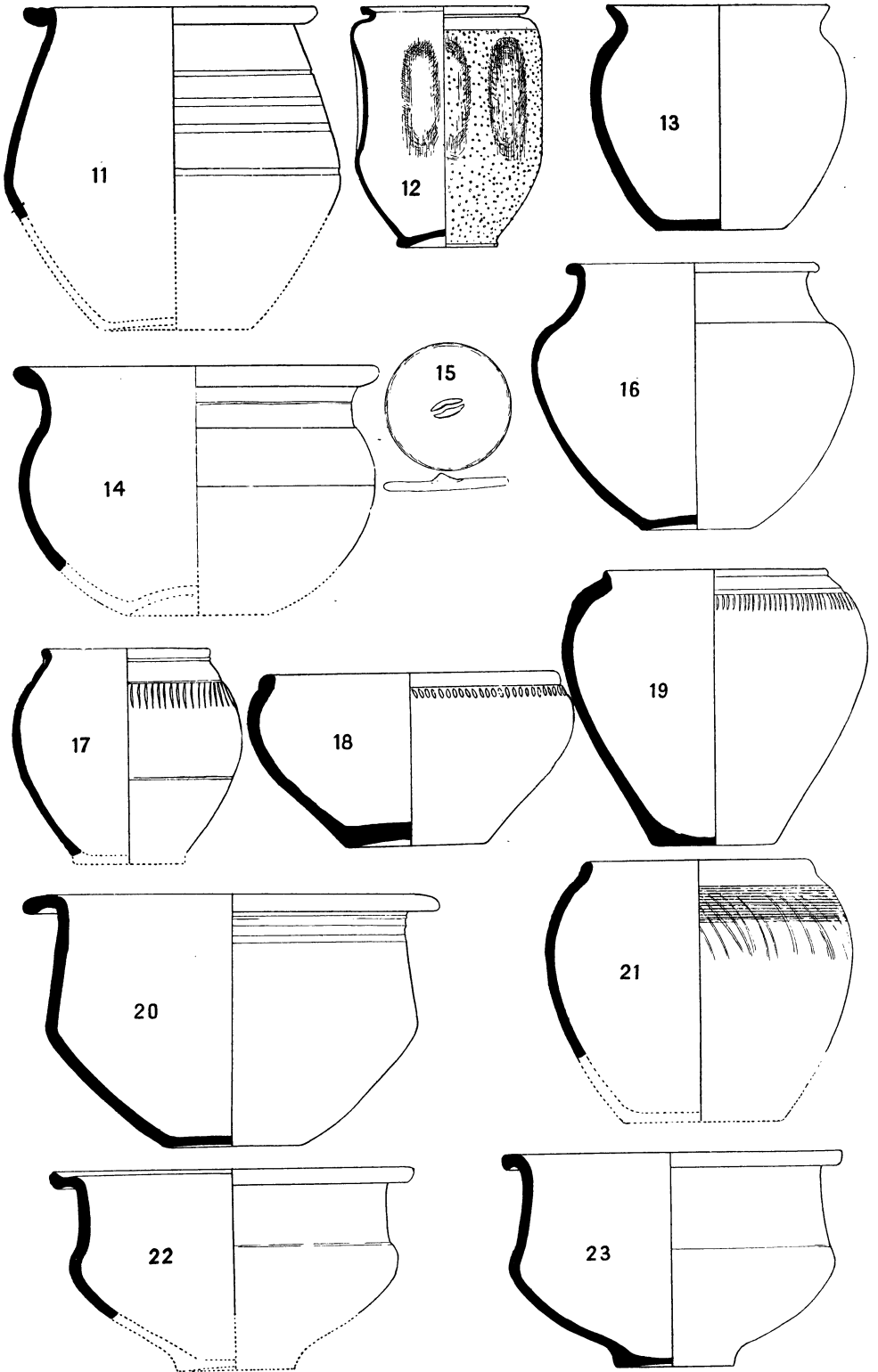
PLATE XX



Coarse pottery ( $\frac{1}{4}$ ), pp. 92-3

*Published by the Society of Antiquaries of London, 1926*

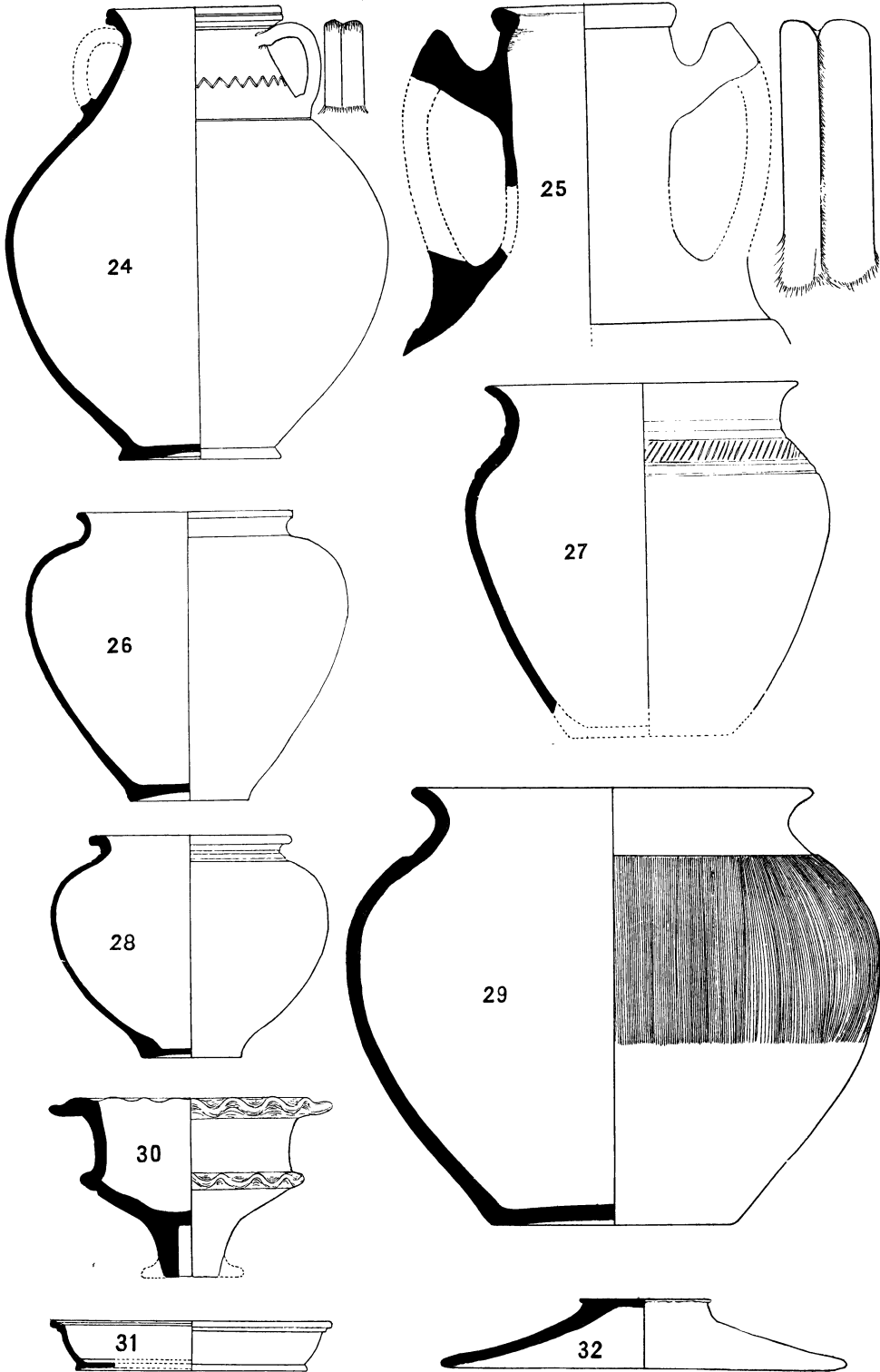
PLATE XXI



Coarse pottery ( $\frac{1}{4}$ ), pp. 93-4

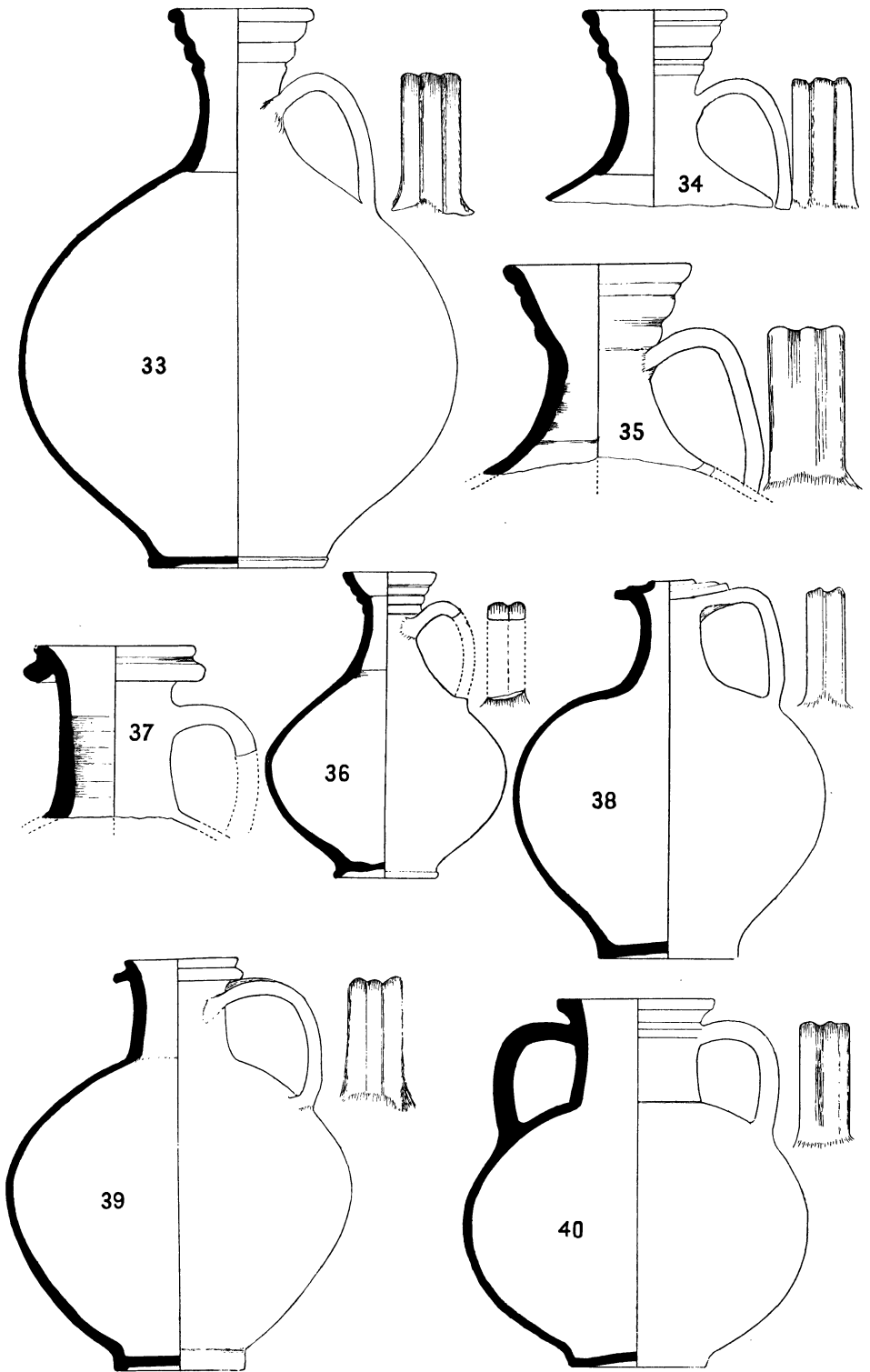
*Published by the Society of Antiquaries of London, 1926*

PLATE XXII



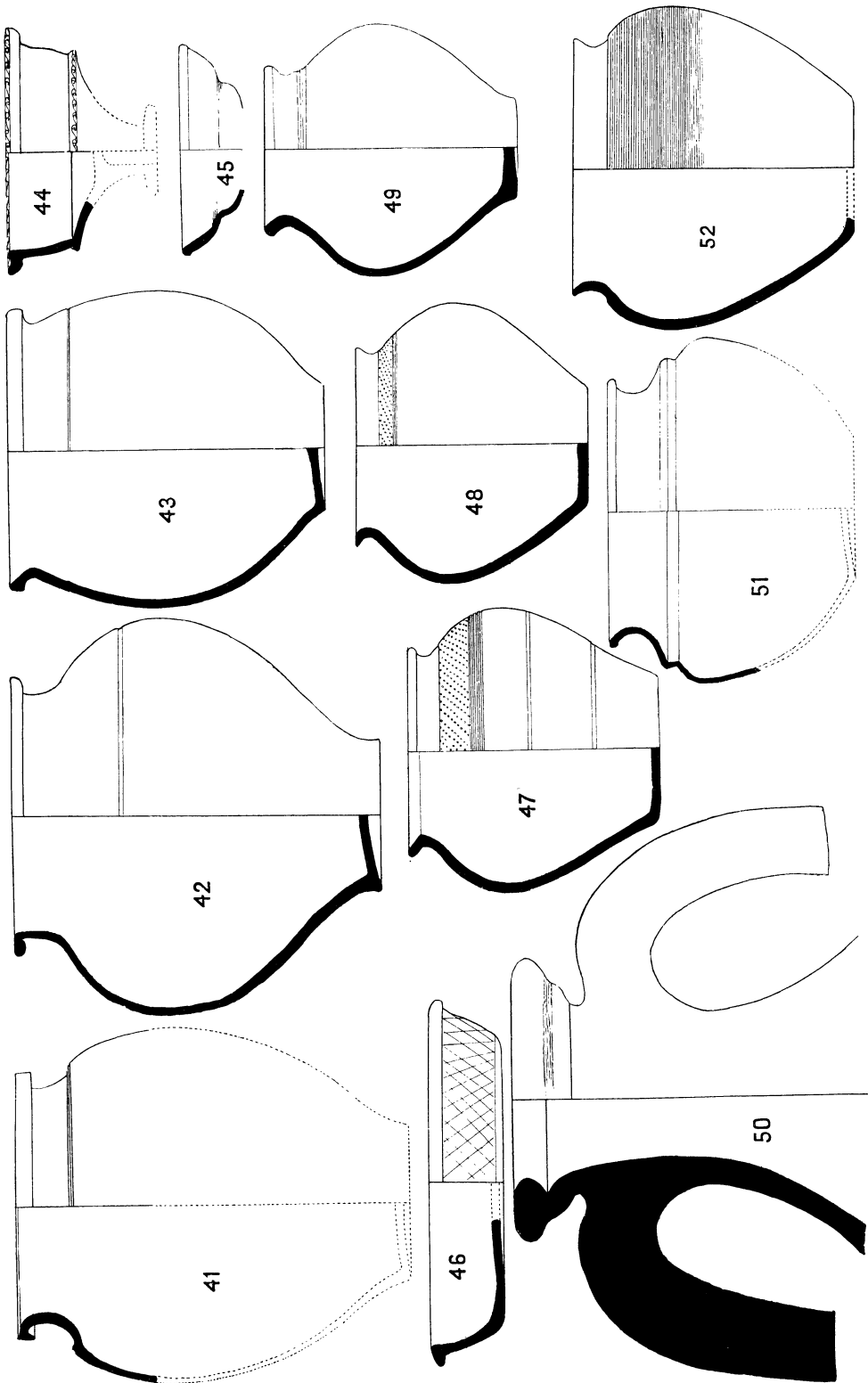
Coarse pottery ( $\frac{1}{4}$ ), pp. 94-5

PLATE XXIII



Coarse pottery ( $\frac{1}{4}$ ), pp. 95-6

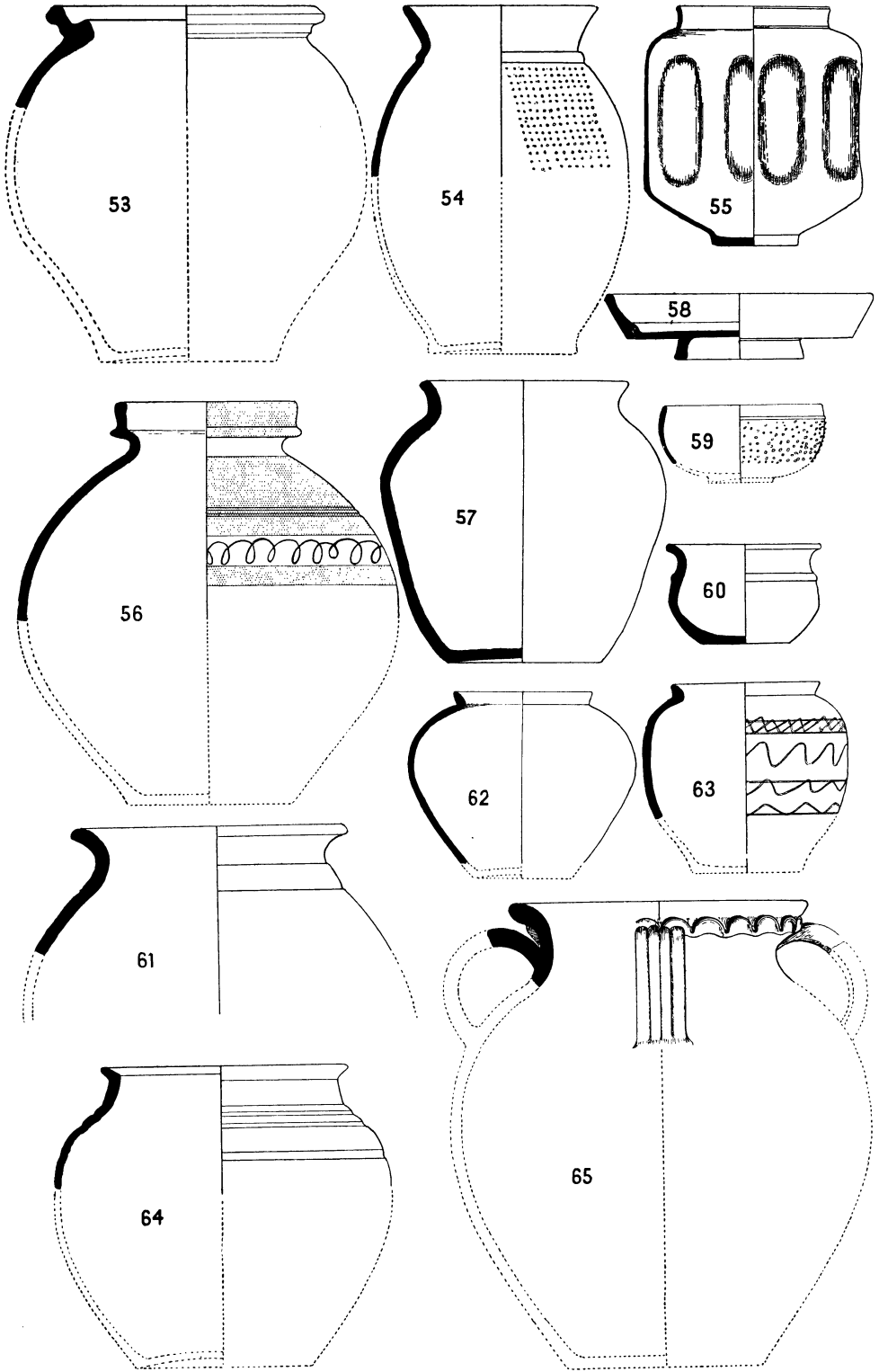
PLATE XXIV



Coarse pottery ( $\frac{1}{4}$ ), pp. 96-7

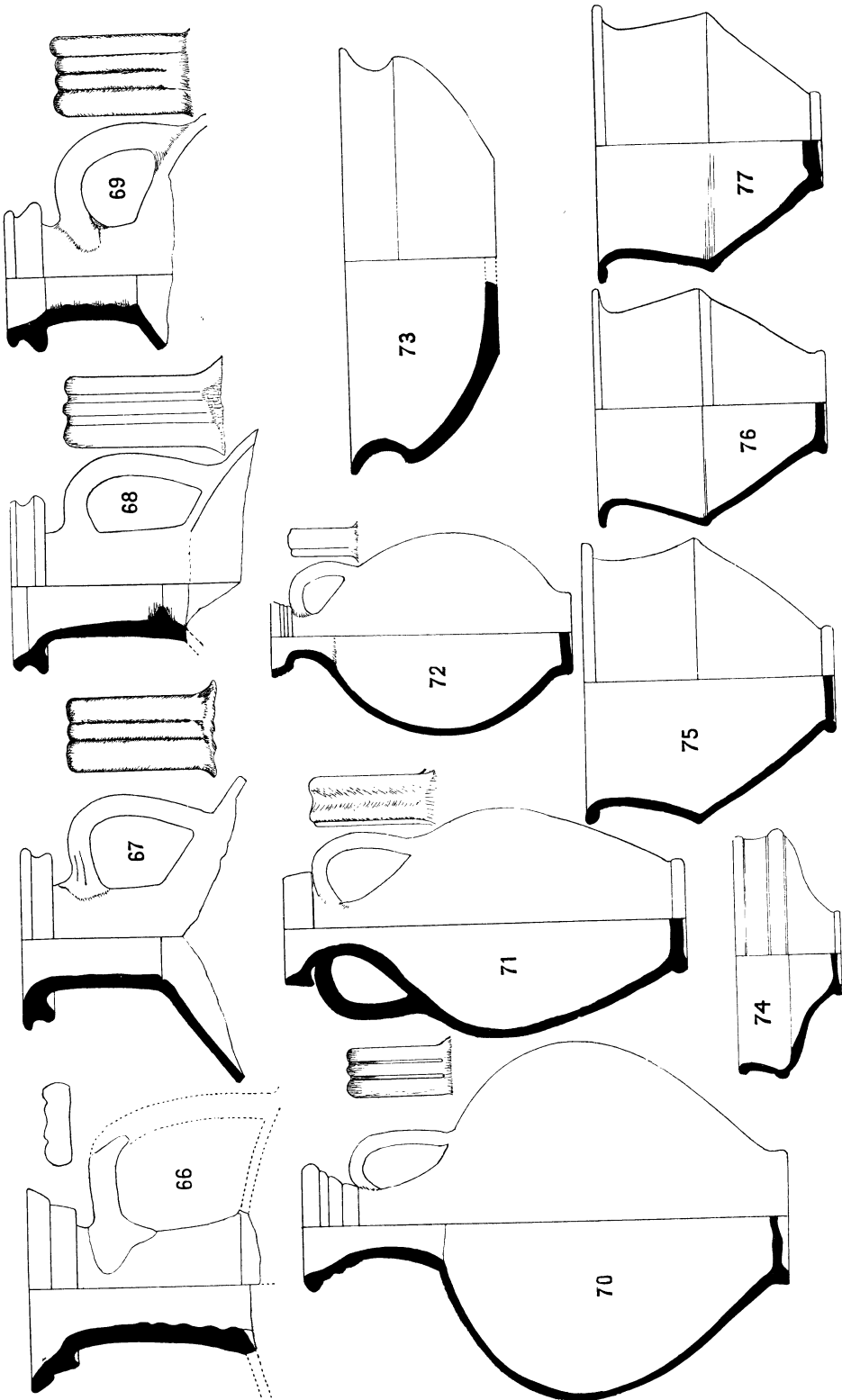
*Published by the Society of Antiquaries of London, 1926*

PLATE XXV



Coarse pottery ( $\frac{1}{4}$ ), pp. 98-9

PLATE XXVI

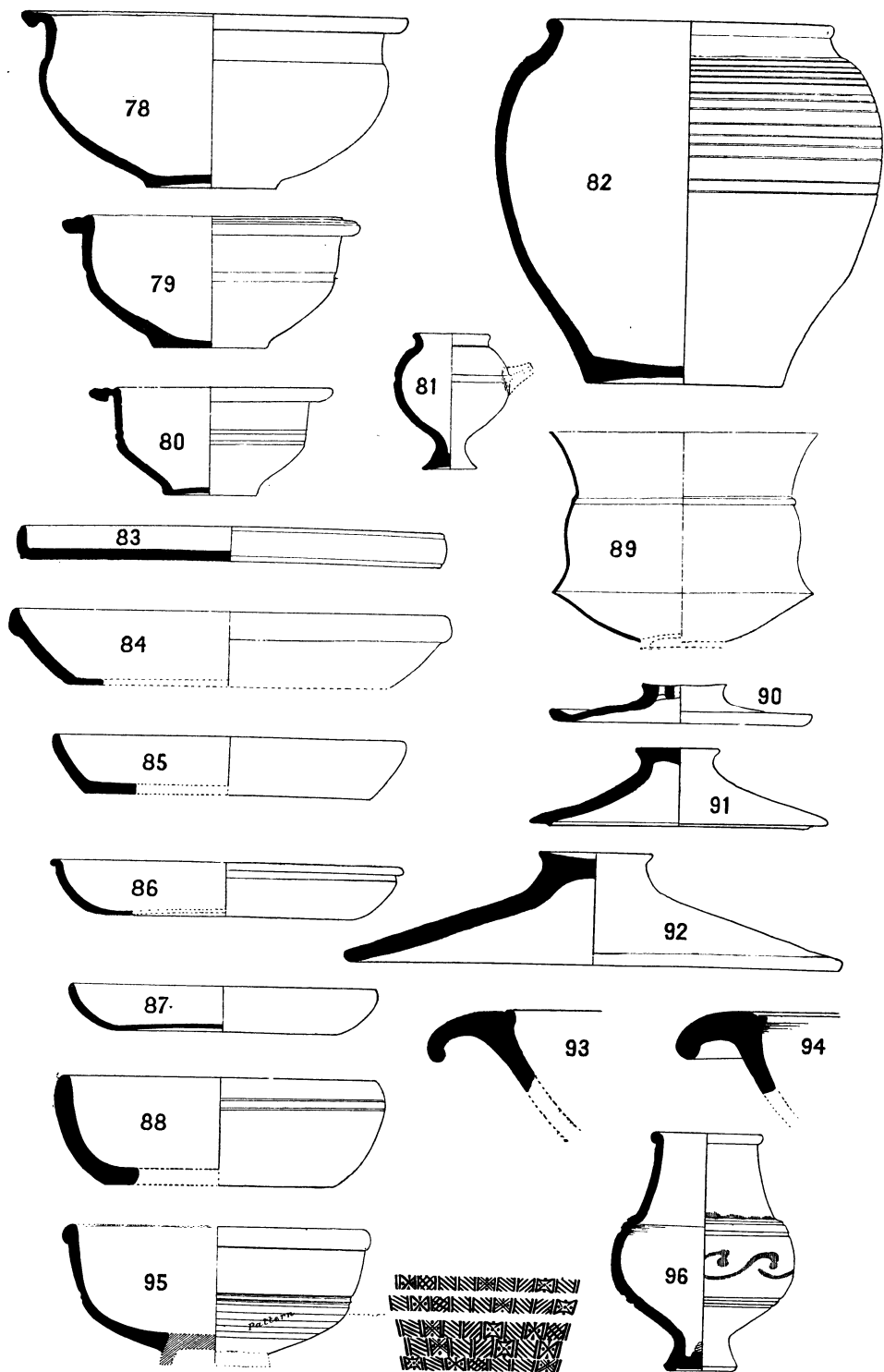


Coarse pottery ( $\frac{1}{4}$ ), pp. 99-100

*Published by the Society of Antiquaries of London, 1926*

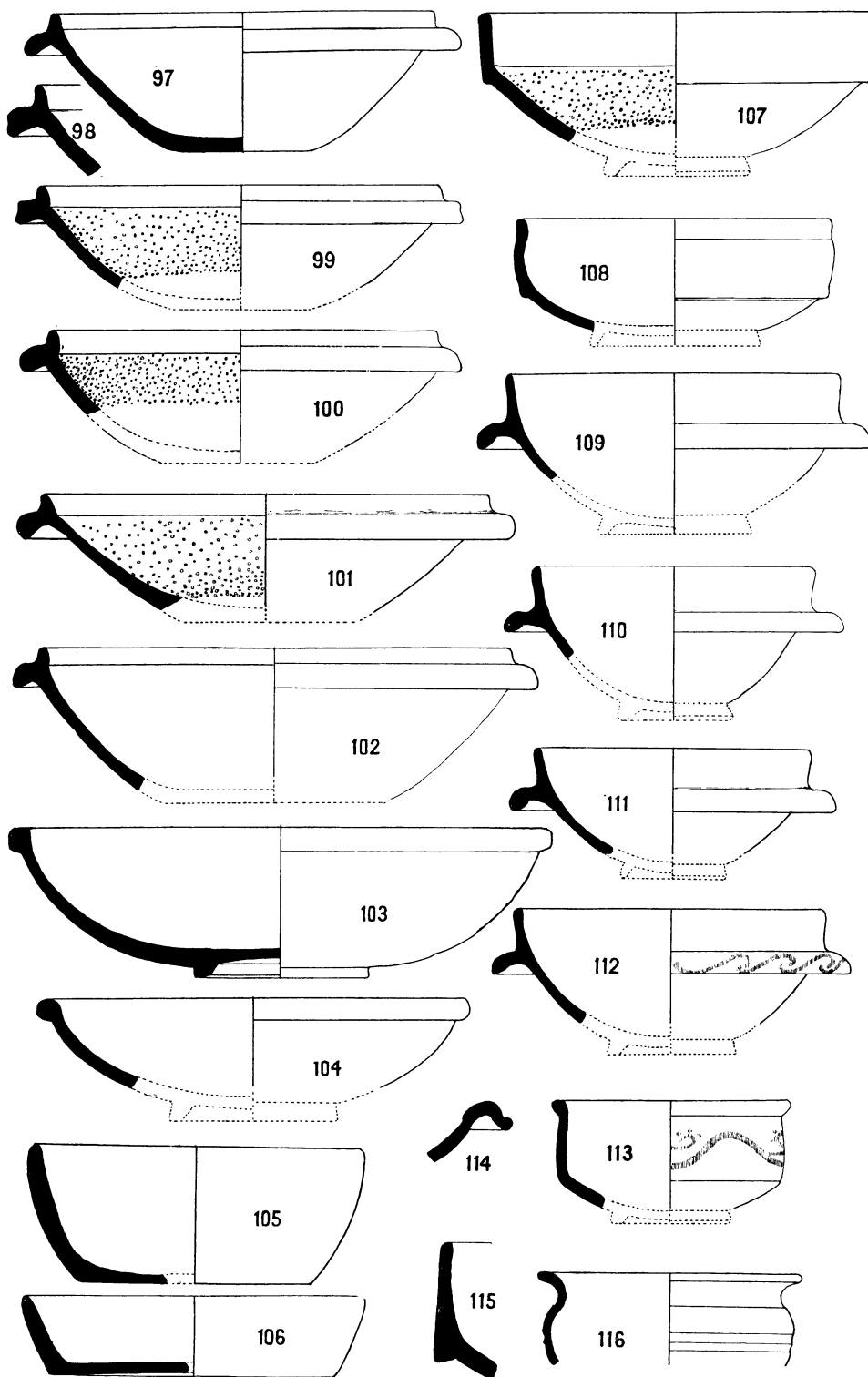


PLATE XXVII



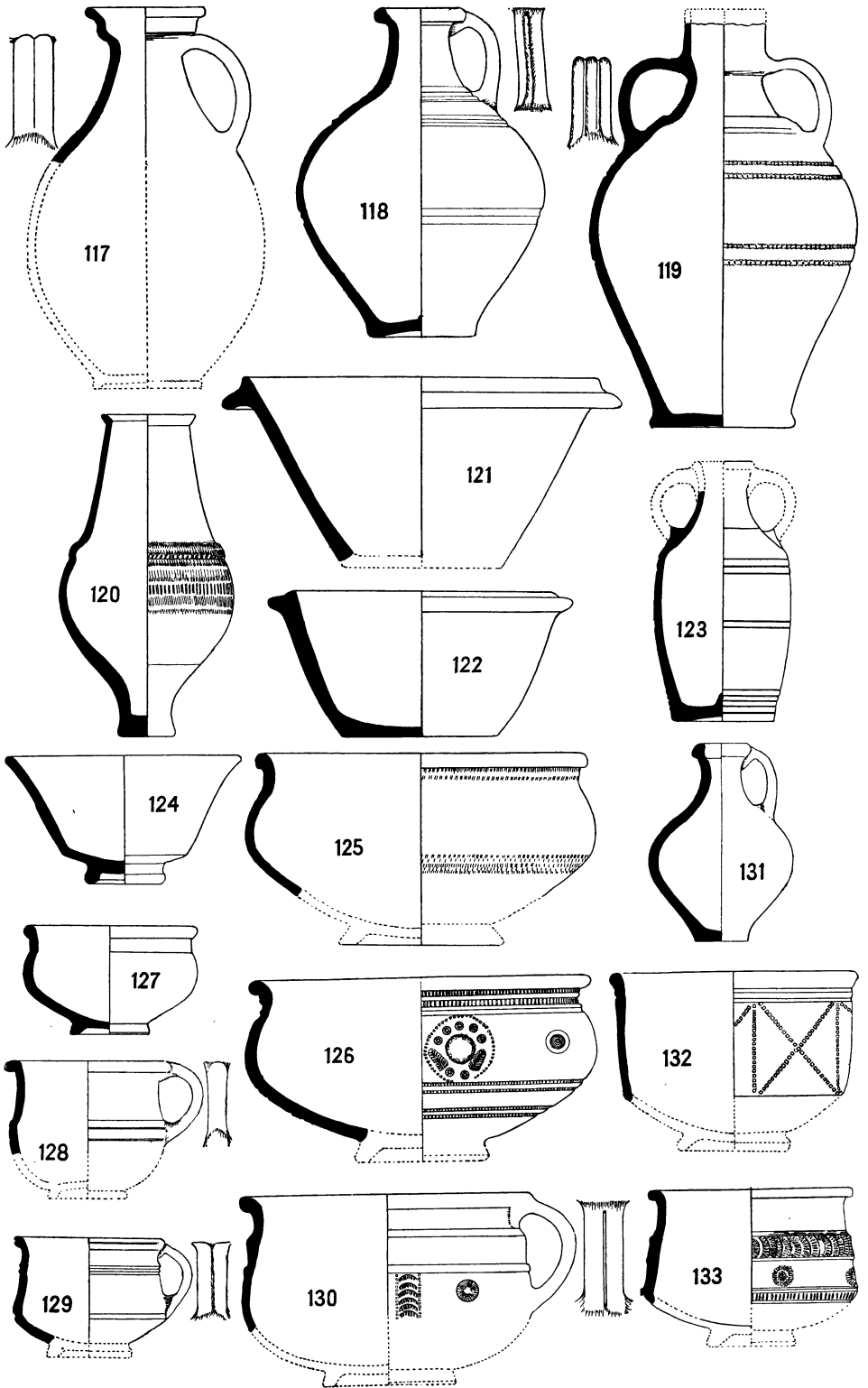
Coarse pottery ( $\frac{1}{4}$ ), pp. 100-2

PLATE XXVIII



Coarse pottery ( $\frac{1}{4}$ ), pp. 102-4

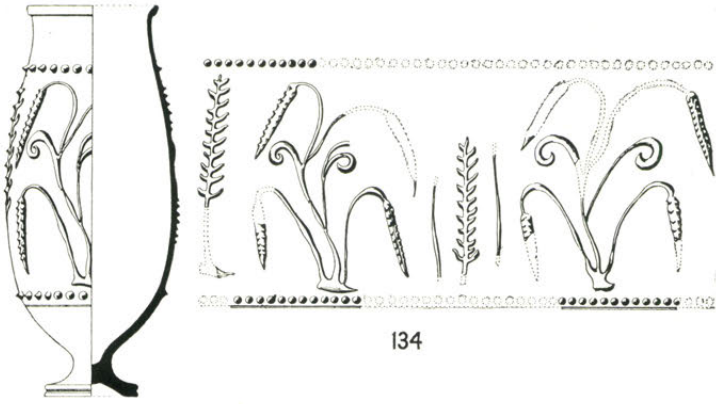
PLATE XXIX



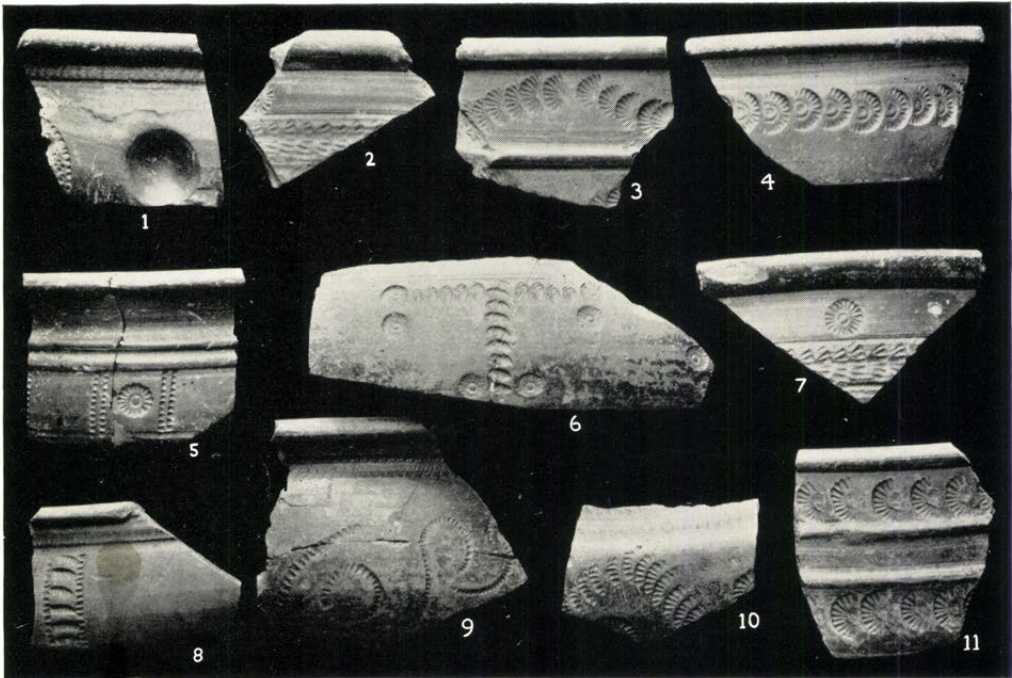
Coarse pottery ( $\frac{1}{4}$ ), pp. 104-6

*Published by the Society of Antiquaries of London, 1926*

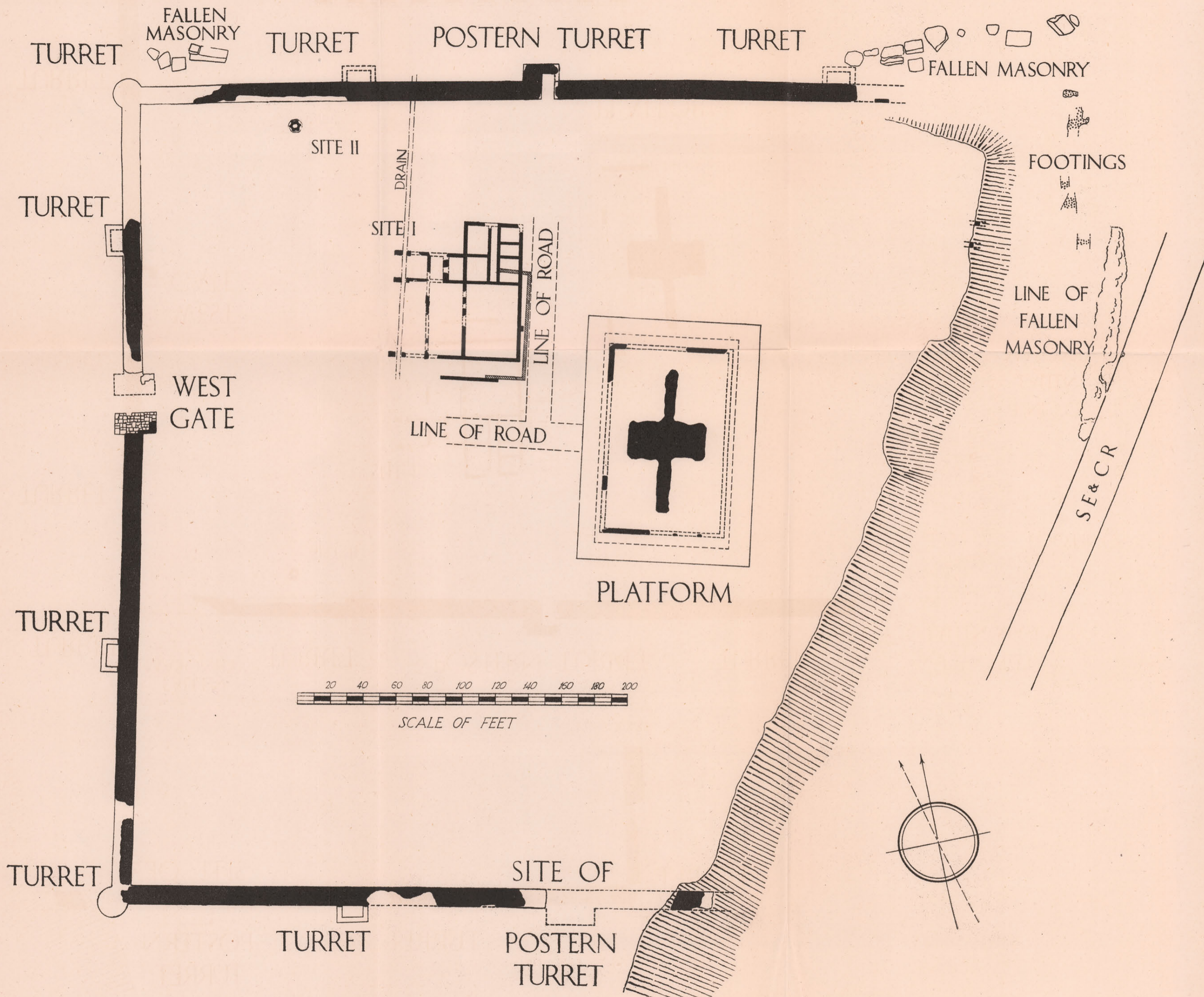
PLATE XXX



Coarse pottery ( $\frac{1}{4}$ ), p. 106



Decoration on late red-coated ware, p. 89

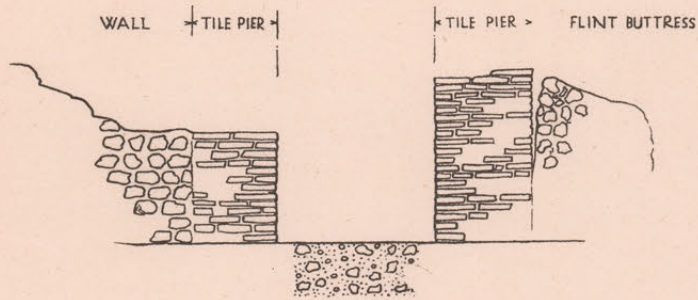


GENERAL SITE PLAN

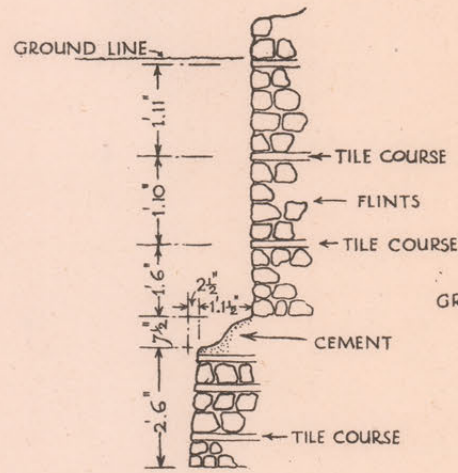
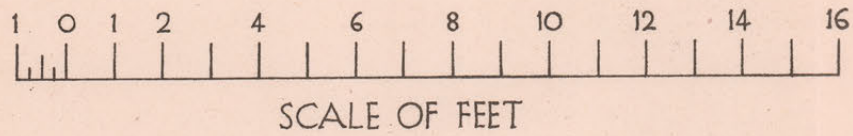
Published by the Society of Antiquaries of London, 1926

H.M. Office of Works, del.

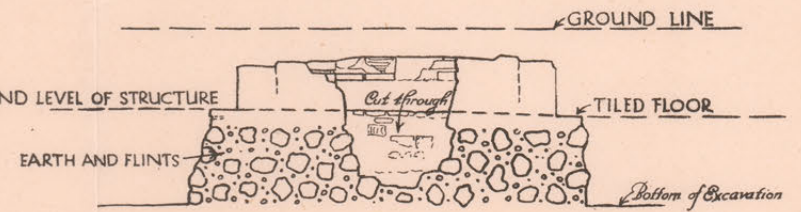




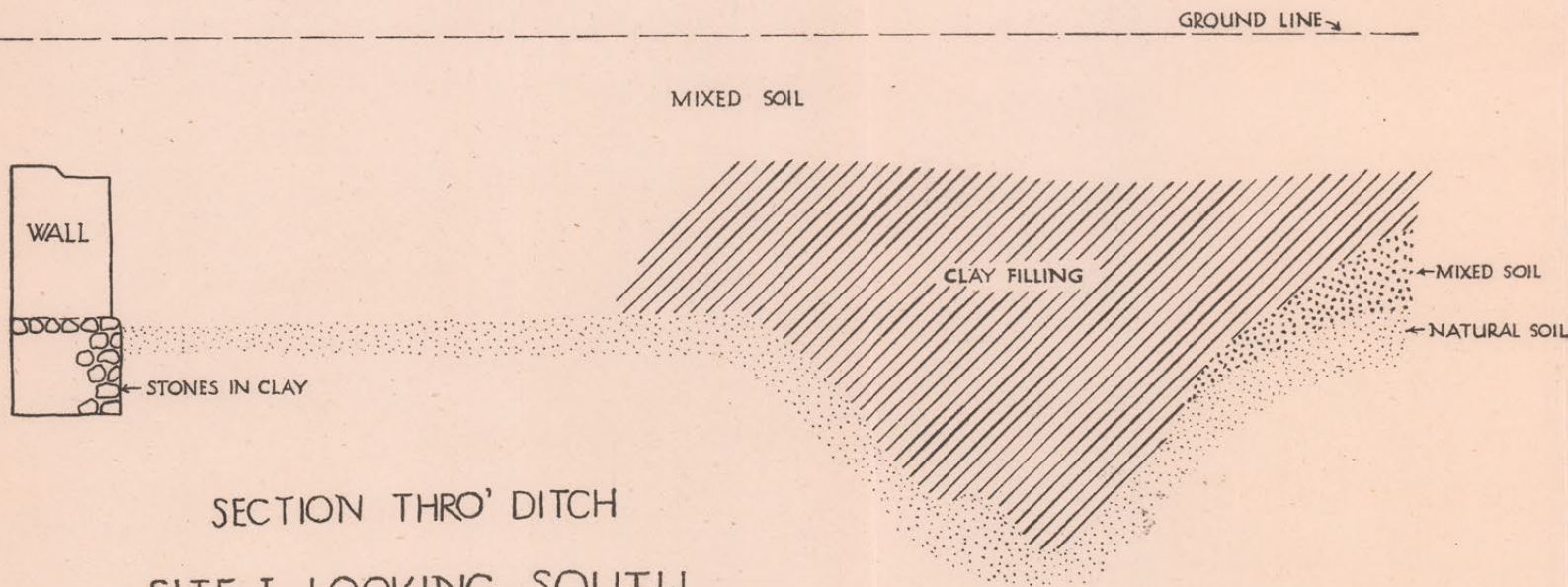
SECTION THRO' DRAIN BETWEEN TILE PIERS



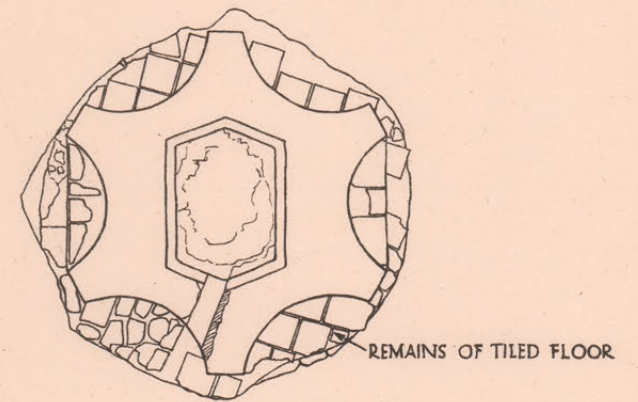
SECTION THRO' BASE (INTERIOR) OF CURTAIN WALL AT X



SECTION

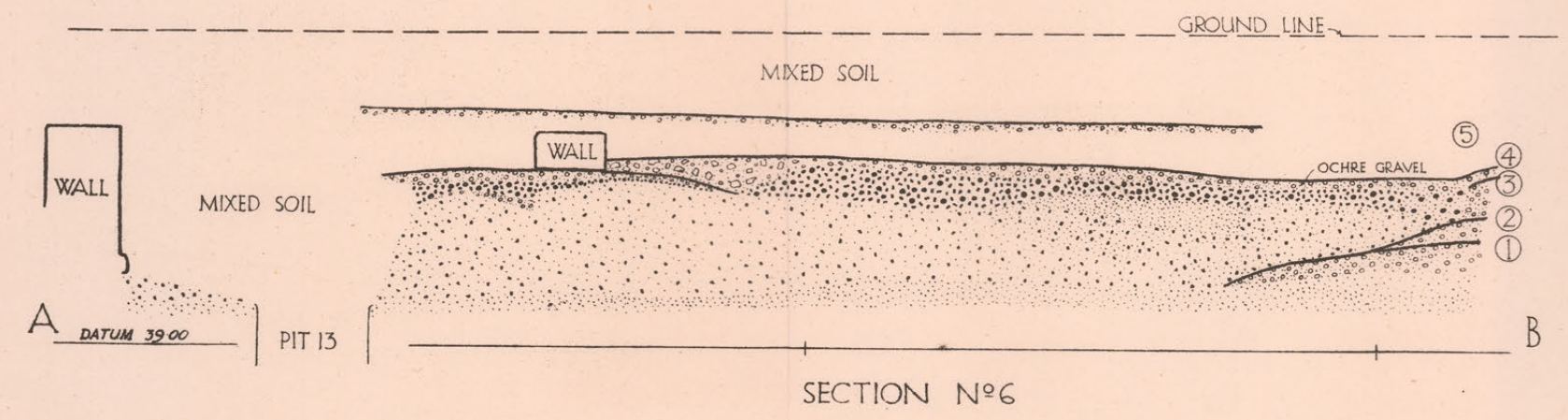
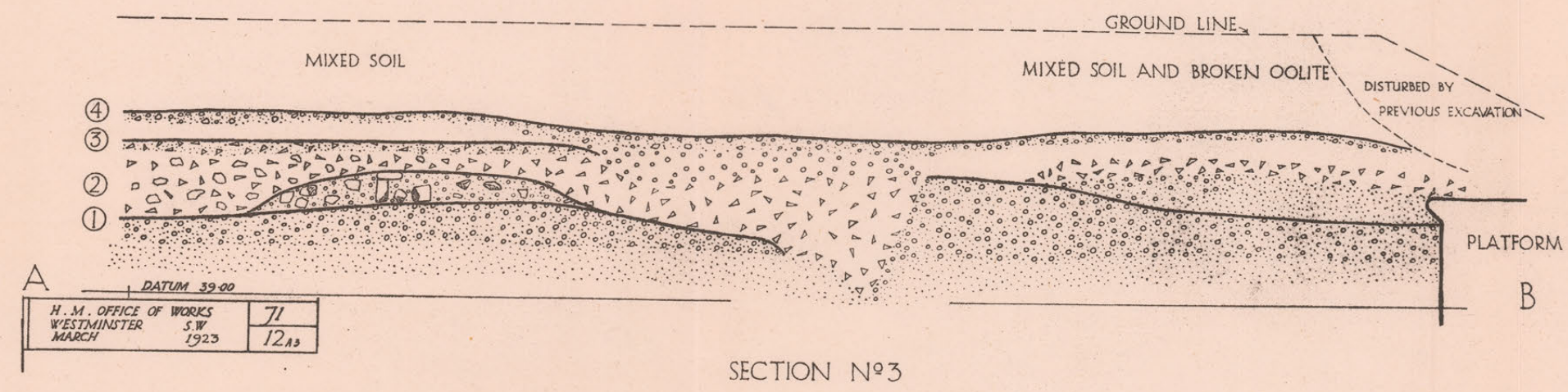
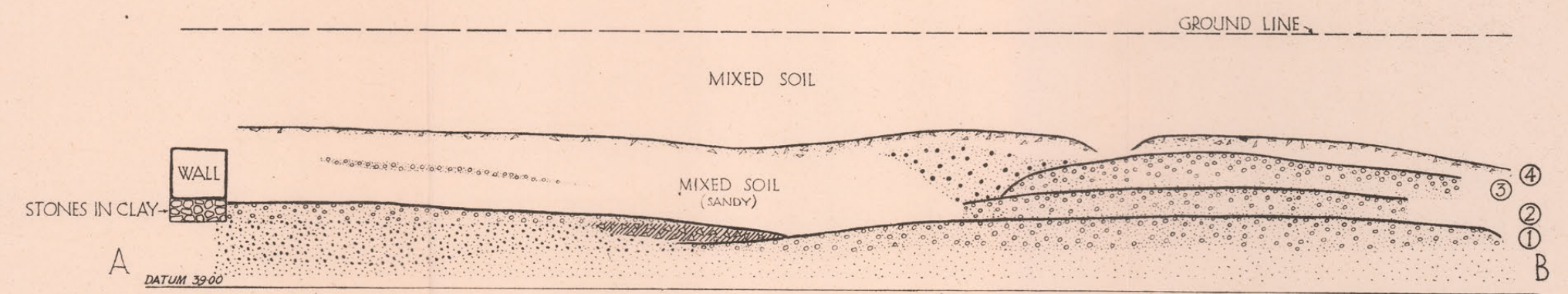
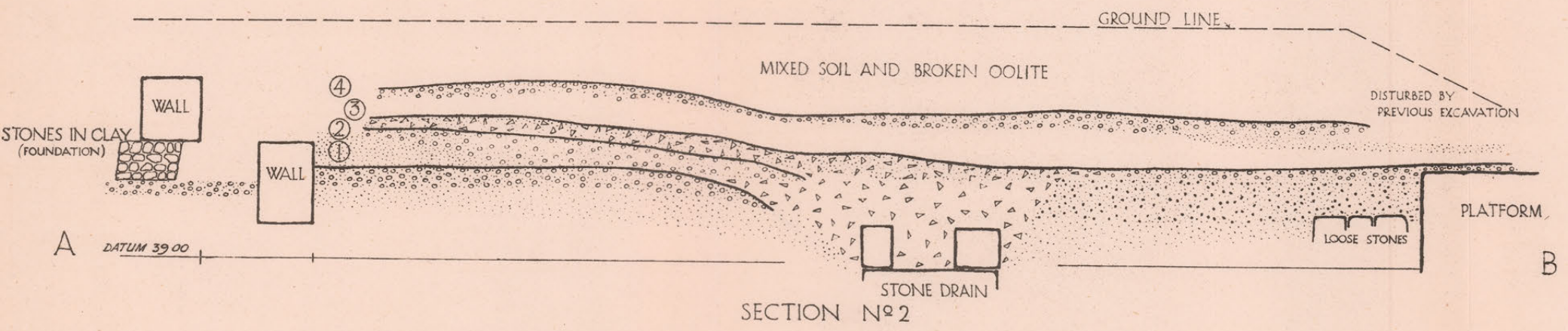
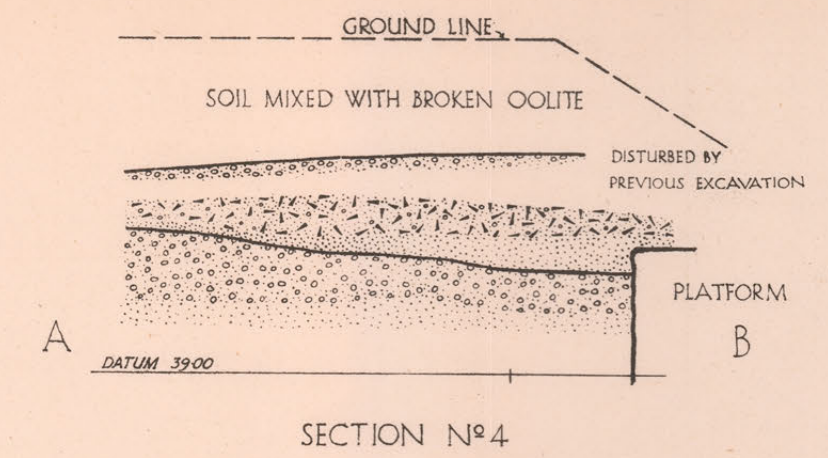
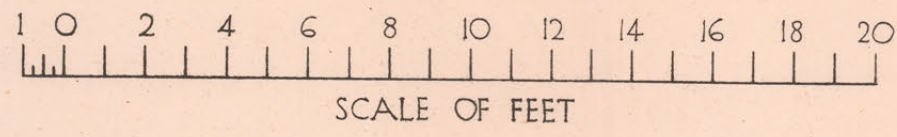
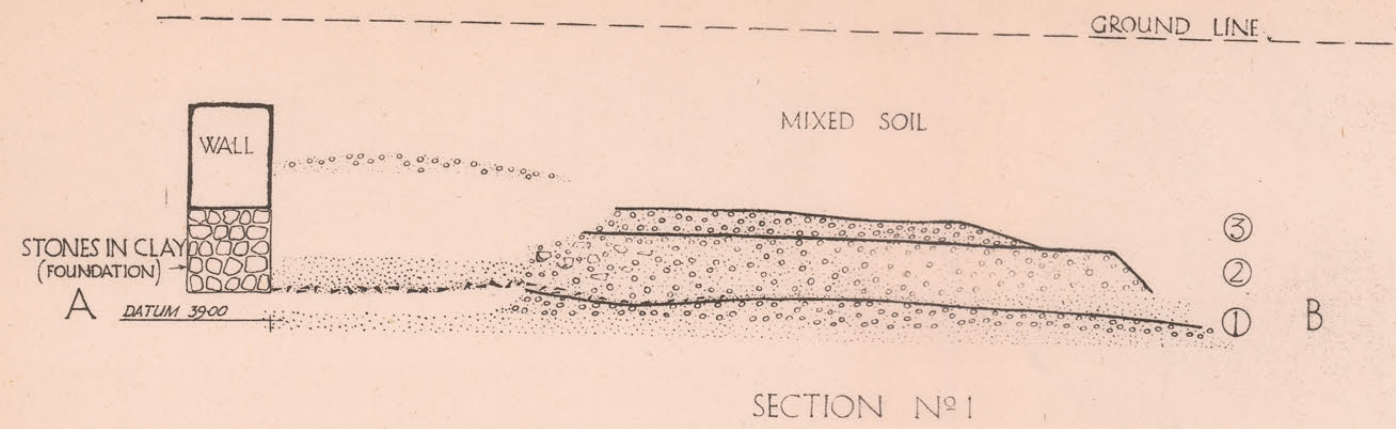


SECTION THRO' DITCH  
SITE I, LOOKING SOUTH



PLAN  
SITE 2

H.M. Office of Works, del.



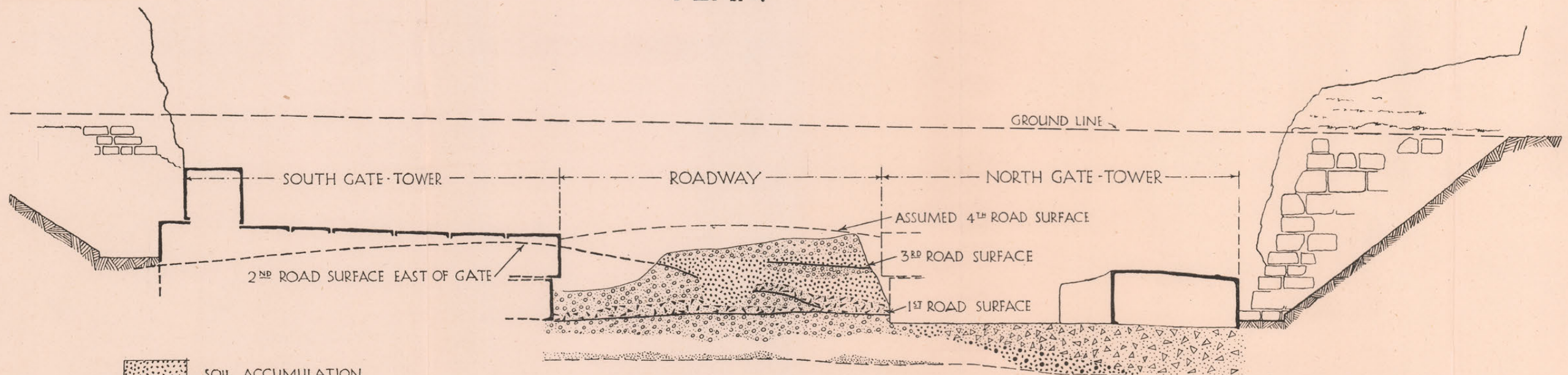
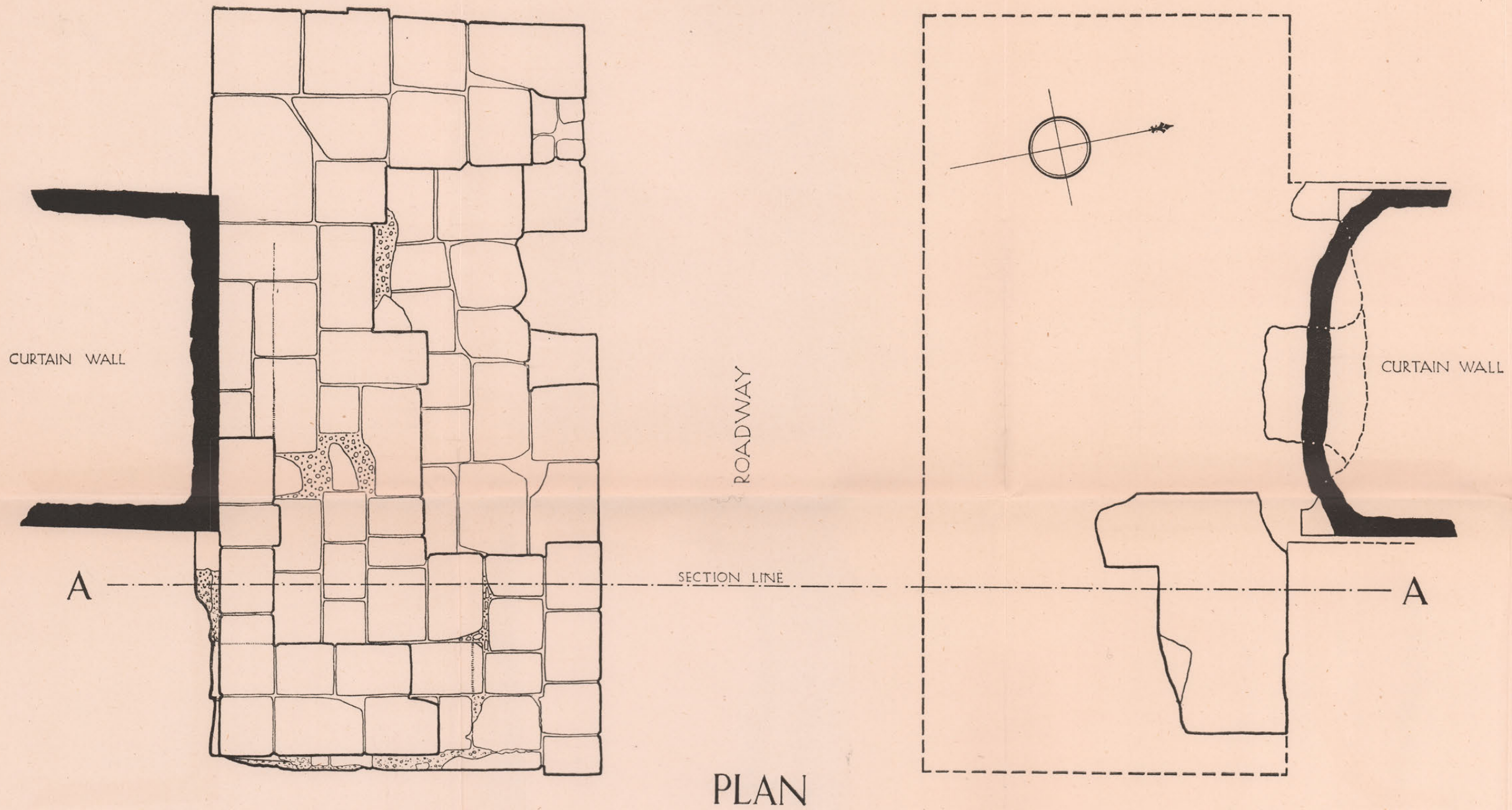
- MIXED SOIL
- PEBBLES (SHINGLE) ROAD METAL
- SOIL MIXED WITH PEBBLES
- SOIL MIXED WITH BROKEN OOLITE
- BROKEN AND DISINTEGRATED OOLITE
- BROKEN OOLITE AND TUFAS
- TUFAS - DISINTEGRATED
- PEBBLES AND FLINTS
- PEBBLES AND LUMP CHALK
- RUBBISH - OYSTER SHELLS AND POTTERY
- SOIL WITH TRACES OF BURNING
- WALL PLASTER WITH D°
- SANDY LOAM
- SAND - NATURAL SOIL




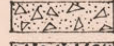

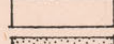
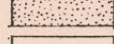
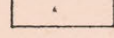
H. M. OFFICE OF WORKS  
WESTMINSTER S.W.  
MARCH 1925

71
12.13

ROAD SECTIONS





-  SOIL ACCUMULATION
-  GRAVEL - ROAD METAL
-  RUBBISH - POTTERY & OYSTER SHELLS
-  CONCRETE - FOUNDATION FOR MASONRY
-  SOIL WITH TRACES OF BURNING
-  SANDY CLAY
-  SAND
-  DISTURBED BY PREVIOUS EXCAVATION

### SECTION A.A

INCHES 12 6 0 1 2 3 4 5 6 7 8 9 10 11 12 13 14 15 16 17 18 19 20 FEET

SCALE - HALF INCH TO ONE FOOT

H.M. Office of Works, del.

PLAN OF SECTION OF WEST GATE

Published by the Society of Antiquaries of London, 1926